

Electromagnetic Flow Monitor *magphant*

Flow monitoring in 1" to 80" pipes with
conductive liquids



Monitoring and measurement

- Flow monitoring with selectable limit values (dry-contact relay output)
- Flow velocity measurement via 4 to 20 mA linear current output

Universal application

- One compact flow monitor for all applications
- Installation in 1" pipes up to 80"

Simple operation

- Selectable limit value via rotary switch
- Local potentiometer setting of full-scale value
- Full-scale and limit values can be set up before installation

Safe operation

- Reliable monitoring (4 mA) even with empty pipe
- Electromagnetic Compatibility (EMC) checked according to IEC
- Self-testing electronics
- Galvanically isolated outputs

Advantages

- No moving parts
- Simple to install
- No maintenance
- Rugged, long-life design
- Smallest flow monitor on the market

Magphant Measuring System

Areas of application

The Magphant flow monitor provides necessary flow rate information to advise process operators on the status of plant operation. The electromagnetic measuring principle determines the flow velocity of the conductive liquid at the tip of the sensor. Moving above or below a preset switchpoint (limit value) is indicated by a relay contact.

A 4 to 20 mA signal proportional to the flow is also available for monitoring the flowrate. The Magphant is ideal for process protection and monitoring.

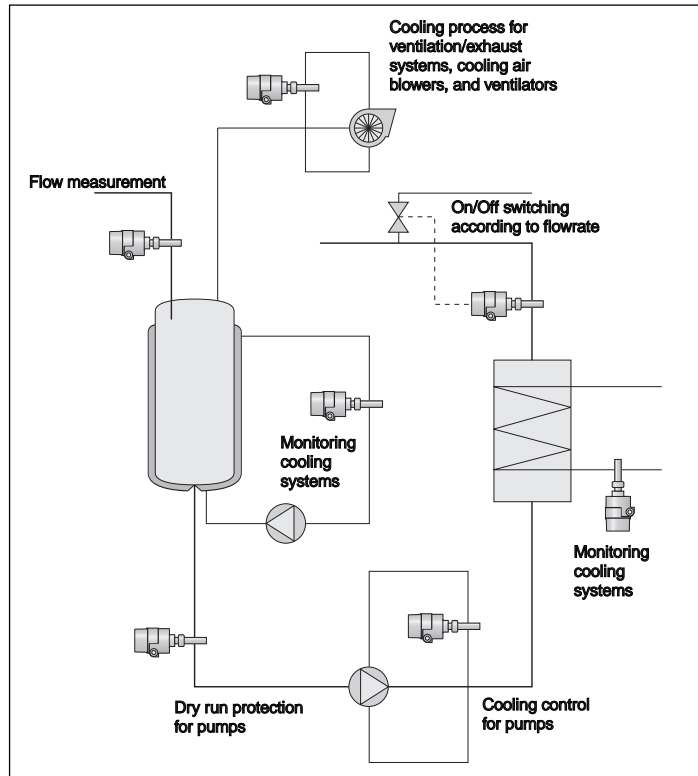

Areas of application:

Process plants

Chemical industry

Energy production

Water treatment

Beverage industry

Dairy industry

Metal production and processing

Farming and horticulture

Applications:

- Dry run protection for pumps
- Flow monitoring
- On/off switching according to flowrate
- Control of cooling systems for pumps, turbines, compressors, heat exchangers
- Flow monitoring
- Monitoring pump function
- Monitoring coolant to bearings for turbines and generators in power plants
- Cooling circuits for transformers
- Status indication of valves in water distribution systems
- Blockage indication in pipes
- Filtration control
- Monitoring cleaning procedures
- Cooling systems in refrigeration plants
- Detecting breakdown of cooling systems for bearings and transmissions
- Control and monitoring of irrigation systems

Functions

Measuring principle

In accordance with Faraday's law of electromagnetic induction, a voltage (U_e) is induced in a conductor that is moved through a magnetic field. In the electromagnetic principle of measurement the flowing and electrically conductive fluid represents the moving conductor. The induced voltage is proportional to the flow velocity and is fed to the amplifier by a pair of electrodes.

Microprocessor-controlled electronics, utilizing patented "Integrated Autozero Circuit" guarantees a stable zero-point and converts the voltage into an analog 4 to 20 mA scaled output signal.

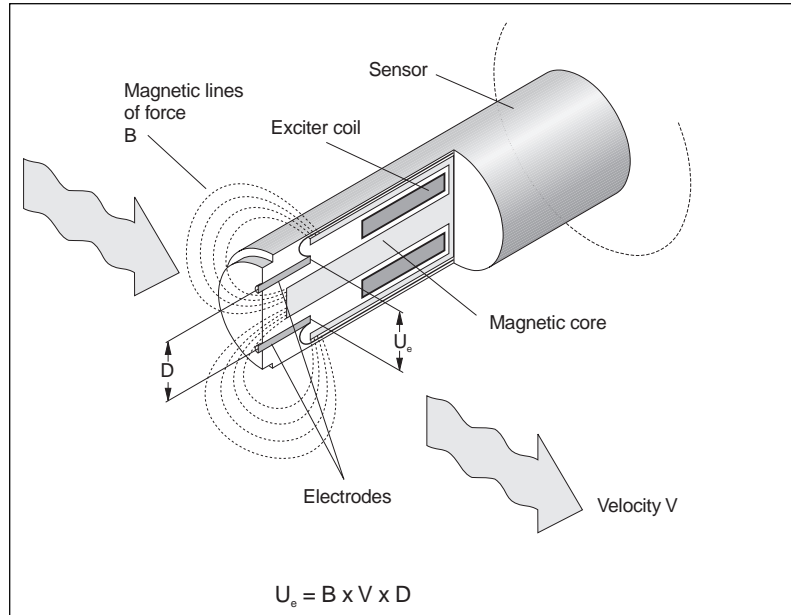

Design

Measuring system design

A construction overview of the Magphant measuring system is shown in the diagram below

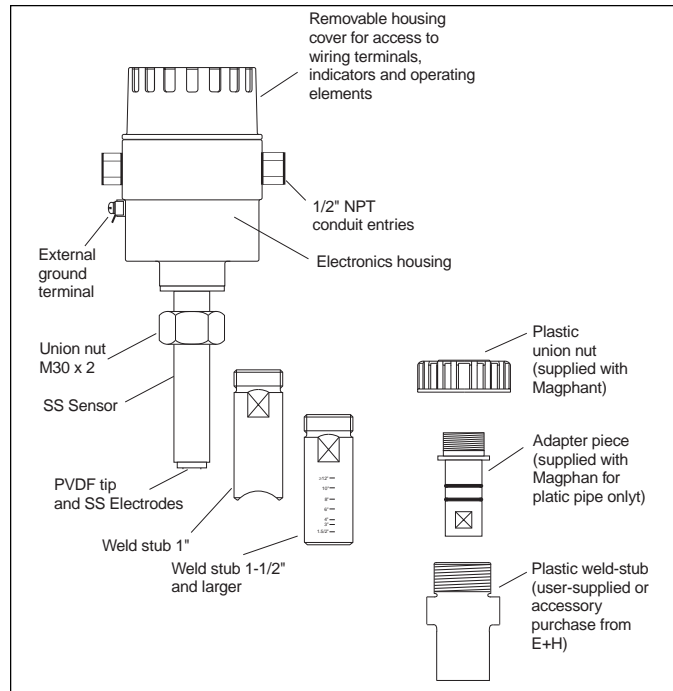

Mounting Instructions

Orientation in the piping

For best results, the Magphant should be mounted in vertical piping. A minimum of 5 to 10 straight pipe diameters before and after the sensor should be maintained to ensure an even flow over the electrodes.

Should horizontal piping be used, the sensor should be mounted to the side or downwards (45° below horizontal) to ensure the electrodes are always immersed in flowing fluid.

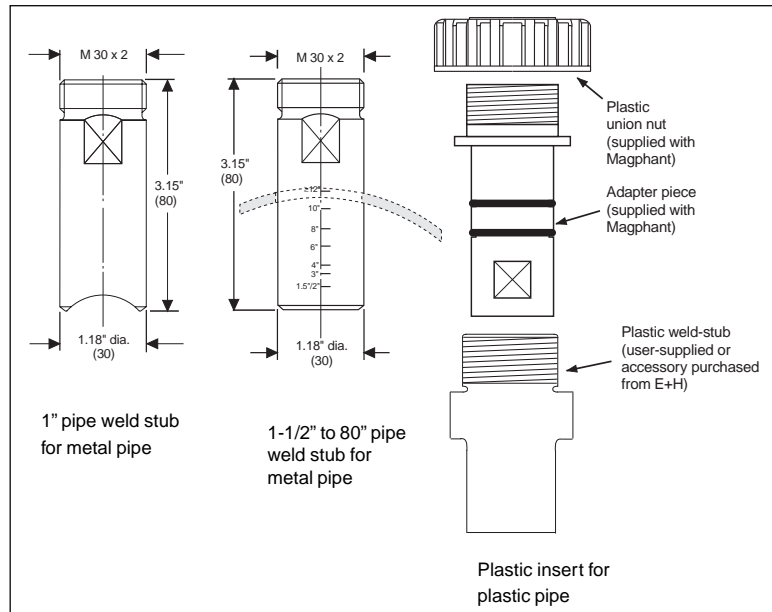
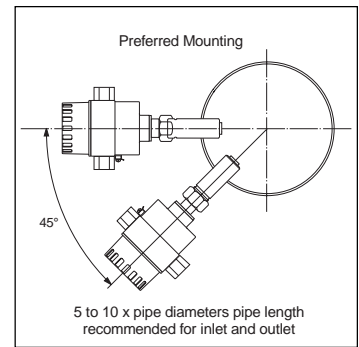

Steel pipe version, 1"

The sensor is mounted using the weld stub supplied. For a 1" pipe, the weld stub has a pre-cut radius to match the pipe outer diameter. Opening size in the pipe for the sensor tip is 0.91" (23 mm).

Steel pipe version, 1-1/2" and larger

For 1-1/2" piping and larger, the weld stub has a graduated scale marked for proper insertion according to pipe diameter. The opening in the pipe to insert the weld stub is 1.18" (30 mm). Ensure the weld stub is perpendicular to the axis of the piping before welding.

NOTE: Do not weld the stub with the sensor installed.

Specify carbon steel or stainless steel stub depending on your process piping.

Plastic pipe version, 1/2" to 12"

The plastic insert fitting for either PVC or Polypropylene pipe comes in one standard size, but is USER modified for overall length and insertion depth before installation.

NOTE: The Magphant for steel piping cannot be used in plastic pipe. The insertion length is different and will not measure properly.

The Magphant can be installed in existing T-fittings (or user-supplied T-fittings) where other styles of insertion type instruments are being used.

Operational safety

Comprehensive self-monitoring of the measuring system assures high safety. Any error messages that do occur (process errors, instrument system errors) are immediately signalled via the current and relay outputs.

The Magphant measuring system fulfills all general requirements for electromagnetic compatibility (EMC) according to CE (EN 50081-1-2 and EN 50082-1-2). Protection type NEMA 4X is standard.

Electrical Connection

Warning!

Do not install, wire or dismantle the instrument when the power supply is switched on.

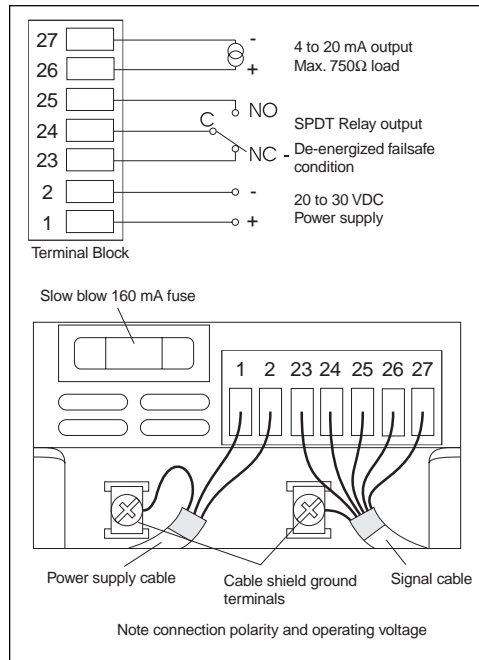

Current output

The Magphant has an analog output which is proportional to the flow velocity. The 4 to 20 mA output signal can be used for other systems such as PLCs, recorders, controllers, etc.

Relay Output

The Magphant has a dry change-over contact which is especially suitable for monitoring purposes. The relay de-energizes when exceeding the range of set limit values (minimum/maximum fail-safe).

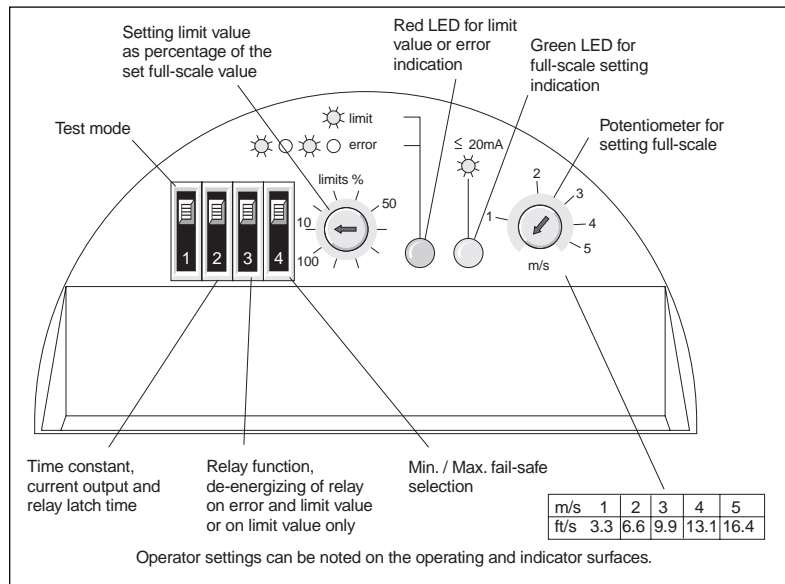

Take a test drive: Free simulation software which fully simulates the operation of the Magphant is available from Endress+Hauser on diskette, or can be down loaded from the Endress+Hauser web site at www.us.endress.com.

Dimensions

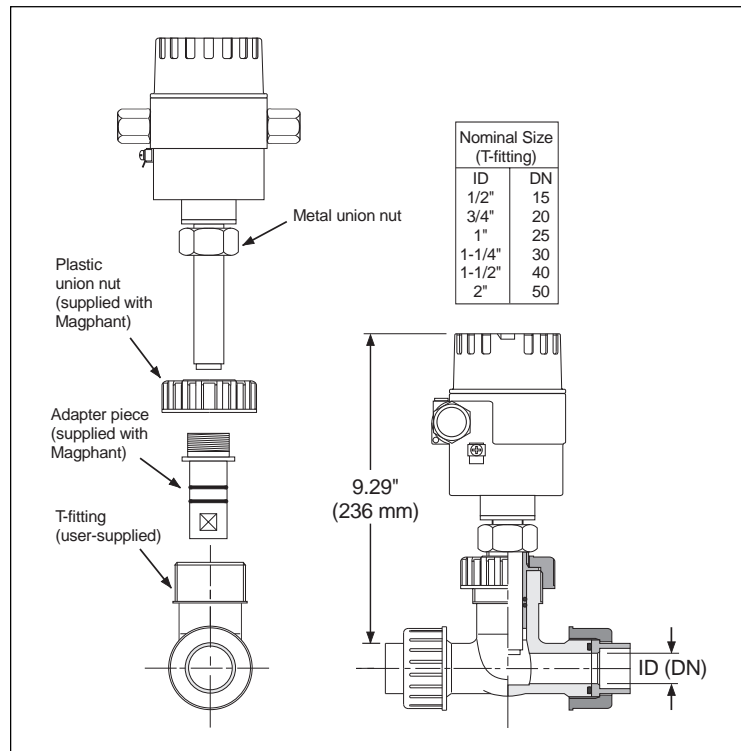
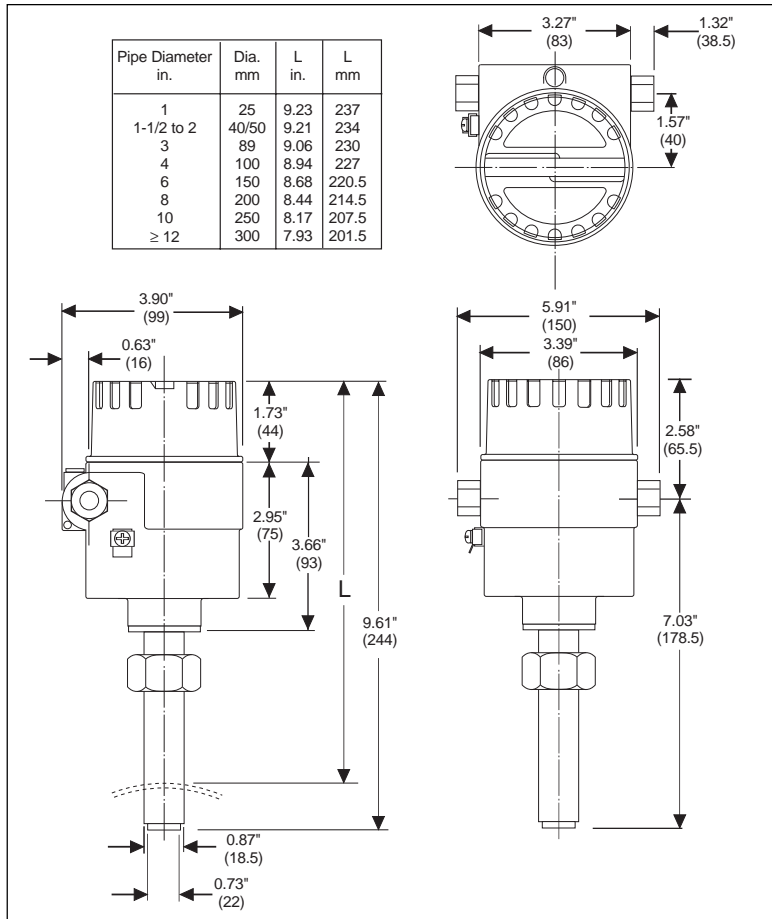

Technical Data

<p>Power Supply</p> <p>Power Consumption</p> <p>Outputs</p>	<p>20 to 30 VDC (24 VDC nominal)</p> <p>< 2.5 W</p> <p>Current: 4 to 20 mA, active. The measuring system can monitor flow in both directions, i.e. bidirectional. The current output is always positive. The relay responds in both flow directions.</p>
	<p>Relay output: SPDT dry change-over contact, 60 VAC / 0.4 A; 75 VDC / 0.5 A</p>
<p>Ambient Temperature</p> <p>Process Temperature</p>	<p>-4° to +140°F (-20° to +60°C)</p> <p>-4° to +250°F (-20° to +120°C), with weld stub of 316L SS and SS clamp ring.</p> <p>-4° to +212°F (-20° to +100°C), with weld stub of A570 carbon steel, SS clamp ring and NBR gasket</p>
<p>Pressure</p>	<p>Steel version, 230 psig at 77°F (16 bar at 25°C)</p> <p>Steel version, 145 psig at 250°F (10 bar at 120°C)</p> <p>PVC version, 145 psig at 77°F (10 bar at 25°C)</p> <p>PVC version, 14 psig at 140°F (1 bar at 60°C)</p> <p>PP version, 145 psig at 68°F (10 bar at 20°C)</p> <p>PP version, 29 psig at 176°F (2 bar at 80°C)</p>
<p>Full-scale Value</p> <p>Minimum Mesaurable Flow</p>	<p>1.32 to 23.1 ft/s (0.4 to 7 m/s) invinitely variable</p> <p>Output cuts off at 0.165 ft/s and resumes again upon exceeding 0.33 ft/s (50% hysteresis)</p>
<p>Accuracy</p>	<p>± 2% of rate at measuring electrode with local calibration at flow velocities > 1.32 ft/s (0.4 m/s)</p>
<p>Reproducibility</p>	<p>± 2% of rate</p>
<p>Conductivity</p>	<p>³ 20 mS/cm</p>
<p>Interference Immunity</p>	<p>According to CE EN 50081-1-2 and EN 50082-1-2 when properly grounded</p>
<p>Protection Type</p>	<p>NEMA 4X with 1/2" NPT conduit fittings</p>
<p>Materials</p>	<p>Sensor tip: PVDF, Viton O-ring.</p> <p>Electrodes: 316L SS.</p> <p>Probe: 316L SS with 316Ti SS clamp ring for 316L SS weld stub, or 316L SS with 316Ti SS clamp ring and NBR (Acrylonitril-Butadiene-Copolymer) gasket for A570 weld stub and plastic pipe version.</p> <p>Housing: Aluminum, epoxy powder coated.</p> <p>Weld stub: 316L SS or A570 carbon steel.</p> <p>Plastic pipe: PVC insert fitting for PVC pipe or Polypropylene insert fitting for PP pipe with 316L SS insert adapter.</p>
<p>Approvals</p>	<p>FM approved, non-incendive for Class I, Division 2, Groups A-D.</p> <p>CSA approved, Class I, Division 2, Groups A-D.</p>

Ordering Information

DTI 200 - 1 2 3 4 5

- 1 Version / Sensor Gasket
 - A1 Union nut for 1" and larger pipes
 - A2 Union nut for 1/2" to 12" plastic pipe
- 2 Weld-on Mounting Nipple
 - 1 Compression ferrule, A570 steel with NBR gasket for 1" process pipe (for A1 only)
 - 2 Compression ferrule, A570 steel with NBR gasket for 1-1/2" pipe and larger (for A1 only)
 - 3 Compression ferrule, 316L SS for 1" process pipe (for A1 only)
 - 4 Compression ferrule, 316L SS for 1-1/2" pipe and larger (for A1 only)
 - 5 Adapter for plastic pipes, 316L SS with NBR gasket (for A2 only)
 - 9 Other
- 3 Cable Connection
 - C 1/2" NPT
 - 9 Other
- 4 Approvals
 - 4 FM, NI CI I, Div 2, Grps A-D (standard for 1/2" NPT conduit entry)
 - 9 Other
- 5 Options
 - A Standard version
 - 9 Other

Accessories

PVC Insertion fitting (for A2 sensor only)

PN: 50084842

PP Insertion fitting (for A2 sensor only)

PN: 50084841

NOTE: Insertion fitting is not required for plastic T-fitting applications.

For a display option, the Endress+Hauser DXF 351 flow computer can be used to indicate the scaled 4 to 20 mA output, plus, it can also provide the DC power supply required for the Maphant.

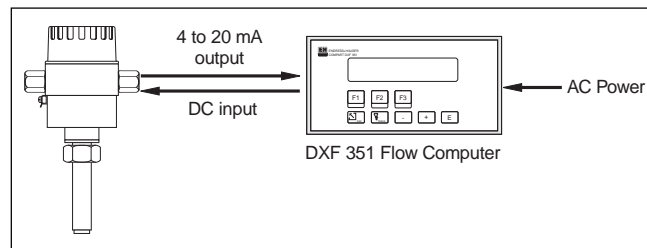
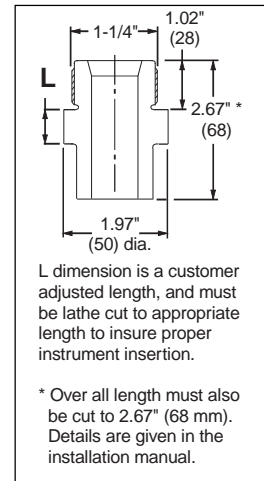

United States

Endress+Hauser
2350 Endress Place
P.O. Box 246
Greenwood, IN 46142
Phone: (317) 535-7138
1-800-428-4344
FAX: (317) 535-8498

Fogarty Engineering
Sales Company
Div. of Endress+Hauser
P.O. Box 901
Harvey, LA 70058
Phone: (504) 366-3264
FAX: (504) 366-3816

Regional Office
Endress+Hauser
600 Kenrick, Ste. B-14
Houston, TX 77060
Phone: (281) 999-199
FAX: (281) 999-1891

Sterling IPC
Div. of Endress+Hauser
68950 Powell Road
P.O. Box 604
Romeo, MI 48065
Phone: (810) 752-0700
FAX: (810) 752-0705

Canada

Endress+Hauser
Canada Ltd.
1440 Graham's Lane
Unit 1, Burlington
ON, L7S 1W3
Phone: (905) 681-9292
1-800-668-3199
FAX: (905) 681-9444

Endress+Hauser
Canada Ltée
6800 Côte de Liesse, Ste. 100
St. Laurent, Que
H4T 2A7
Téléphone: (514) 733-0254
Télécopieur: (514) 733-2924

Mexico

Endress+Hauser
Calle Camino Sta. Teresa 1384
C.P. 10200 Mexico D.F.
Phone: (525)568-9658
FAX: (525) 568-4183

Endress + Hauser
Nothing beats know-how

