

Technical Information

Deltabar S PMD70/75, FMD76/77/78

Differential pressure transmitter
with ceramic and silicon sensors

Overload-resistant and function-monitored, Communication via
HART, PROFIBUS PA or FOUNDATION Fieldbus



Application

The Deltabar S differential pressure transmitter is used for the following measuring tasks:

- Flow measurement (volume or mass flow) in conjunction with primary elements in gases, vapours and liquids
- Level, volume or mass measurement in liquids
- Differential pressure monitoring, e.g. of filters and pumps
- International usage thanks to a wide range of approvals



Your benefits

- Very good reproducibility and long-term stability
- High reference accuracy: up to $\pm 0.075\%$, as PLATINUM version: $\pm 0.05\%$
- Turn down 100:1, higher on request
- Used for flow and differential pressure monitoring up to SIL 2, certified to IEC 61508 by TÜV SÜD
- meets PED (Pressure Equipment Directive)
- HistoROM[®]/M-DAT memory module
- Function-monitored from the measuring cell to the electronics
- Continuous modularity for differential pressure and pressure (Deltabar S – Cerabar S), e.g.
 - replaceable display
 - universal electronics for pressure and differential pressure
- Quick commissioning thanks to quick setup menu
- Easy and safe menu-guided operation on-site, via 4...20 mA with HART, via PROFIBUS PA or via FOUNDATION Fieldbus
- Extensive diagnostic functions

Table of contents

Function and system design	4	Performance characteristics – metallic diaphragms ..	22
Device selection	4	Reference accuracy – PMD75, FMD77, FMD78	22
Overview of diaphragm seal FMD78	5	Total performance – PMD75	22
Measuring principle	7	Warm-up period – PMD75, FMD77, FMD78	22
Flow measurement	8	Dead time, Time constant (T63) – PMD75, FMD77, FMD78 ...	22
Level measurement (level, volume and mass)	9	Influence of the operating pressure on zero point and span – PMD75, FMD77, FMD78	23
Communication protocol	9	Thermal change of the zero output and the output span – PMD75	23
Human interface	10	Performance characteristics – ceramic diaphragms ..	24
On-site display (optional)	10	Reference accuracy – PMD70, FMD76	24
Operating elements	11	Total performance – PMD70, FMD76	24
HistoROM®/M-DAT (optional)	12	Warm-up period – PMD70, FMD76	24
Functional Safety SIL2/IEC 61508 Declaration of conformity (optional)	12	Dead time, Time constant (T63) – PMD75, FMD77, FMD78 ...	24
On-site operation	12	Influence of the operating pressure on zero point and span – PMD70, FMD76	25
Handheld terminals – HART	12	Thermal change of the zero output and the output span – PMD70, FMD76	25
Handheld terminal DXR375 – FOUNDATION Fieldbus	12	Operating conditions (Installation)	26
ToF Tool – HART, PROFIBUS PA, FOUNDATION Fieldbus ...	13	General installation instructions	26
FieldCare – HART, PROFIBUS PA	13	Measuring arrangement	26
Remote operation – FOUNDATION Fieldbus	13	Heat insulation – FMD77	27
Service interface FXA193	13	Wall- and pipe-mounting	27
		Turn the housing	28
		Oxygen applications	28
		Ultra pure gas applications	28
		Diaphragms for materials with hydrogen build-up (Gold-Rhodium coating)	29
		Operating conditions (Environment)	29
		Ambient temperature range	29
		Storage temperature range	29
		Degree of protection	29
		Climate class	29
		Vibration resistance	29
		Electromagnetic compatibility	29
		Overvoltage protection (optional)	30
		Operating conditions (Process)	30
		Process temperature limits	30
		Temperature operating range, seals	30
		Pressure specifications	31
Performance characteristics – general	21		
Reference operating conditions	21		
Long-term stability	21		
Influence of the installation position	21		
Vibration effects	21		

Mechanical construction	32
Housing dimensions T14, optional display on the side	32
Housing dimensions T15, optional display on the top	32
Housing dimensions T17, optional display on the top	32
Process connections PMD70	33
Process connections PMD75	35
Process connection FMD76	38
Process connections FMD77, low-pressure side	40
Process connections FMD77, high-pressure side	41
FMD78 Basic unit	44
Process connection FMD78	45
Weight	52
Material	52
Planning instructions, diaphragm seal systems	54
Applications	54
Design and operation mode	54
Diaphragm seal filling oils	55
Influence of the temperature on the zero point	56
Ambient temperature range	58
Response time	60
Installation instructions	61
Certificates and approvals	63
CE mark	63
Ex approvals	63
Marine certificate	63
Overspill protection	63
CRN approvals	63
Pressure Equipment Directive (PED)	63
Standards and guidelines	63
Ordering information	64
PMD70	64
PMD75	66
FMD76	69
FMD77	72
FMD78	75
Further documentation	78
Innovation	78
Field of Activities	78
Technical Information	78
Operating Instructions	78
Manual for Functional Safety (SIL)	78
Safety Instructions	78
Installation/Control Drawings	79
Overspill protection	79

Function and system design

Device selection

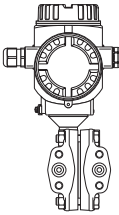
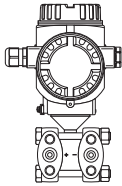
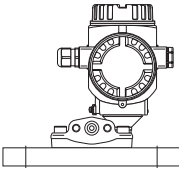
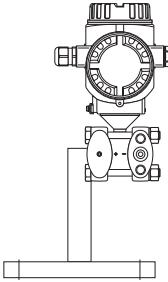
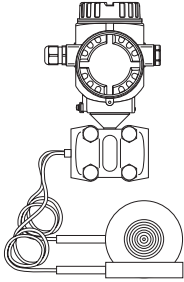
Deltabar S – product family	PMD70	PMD75	FMD76	FMD77	FMD78
	 <p>P01-FMD70xxx-16-xx-xx-xx-000</p> <p>With ceramic measuring diaphragms</p>	 <p>P01-FMD75xxx-16-xx-xx-xx-000</p> <p>With metallic measuring diaphragms</p>	 <p>P01-FMD76xxx-16-xx-xx-xx-000</p> <p>With ceramic measuring diaphragms</p>	 <p>P01-FMD77xxx-16-xx-xx-xx-000</p> <p>With metallic measuring diaphragms and diaphragm seal mounted on one side</p>	 <p>P01-FMD78xxx-16-xx-xx-xx-003</p> <p>With metallic measuring diaphragms and capillary diaphragm seals</p>
Field of application	<ul style="list-style-type: none"> – Flow – Level – Differential pressure 	<ul style="list-style-type: none"> – Flow – Level – Differential pressure 	<ul style="list-style-type: none"> – Level 	<ul style="list-style-type: none"> – Level 	<ul style="list-style-type: none"> – Level – Differential pressure
Process connections	<ul style="list-style-type: none"> – 1/4 – 18 NPT – RC 1/4 	<ul style="list-style-type: none"> – 1/4 – 18 NPT – RC 1/4 	Low-pressure side (–): <ul style="list-style-type: none"> – 1/4 – 18 NPT – RC 1/4 High-pressure side (+): <ul style="list-style-type: none"> – DN 80 – DN 100 – ANSI 3" – 4" – JIS 80A – 100A 	Low-pressure side (–): <ul style="list-style-type: none"> – 1/4 – 18 NPT – RC 1/4 High-pressure side (+): <ul style="list-style-type: none"> – DN 50 – DN 100 – ANSI 2" – 4" – JIS 80A – 100A 	<ul style="list-style-type: none"> – Wide range of diaphragm seals, → see page 5, section "Overview of diaphragm seal FMD78"
Measuring ranges	from –25...+25 mbar to –3...+3 bar	from –10...+10 mbar to –40...+40 bar	from –100...+100 mbar to –3...+3 bar	from –100...+100 mbar to –16 bar...+16 bar	from –100...+100 mbar to –40...+40 bar
Overload ¹	on one side: max. 100 bar on both sides: max. 150 bar	on one side: max. 420 bar on both sides: max. 630 bar	on one side: max. 100 bar	on one side: max. 160 bar	on one side: max. 160 bar on both sides: max. 240 bar
Process temperature	–20...+85°C (–4...+185°F)	–40...+120°C (–40...+248°F)	–20...+85°C (–4...+185°F)	up to + 350°C (+662°F)	up to +350°C (+662°F)
Ambient temperature	–20...+85°C (–4...+185°F)	–40...+85°C (–40...+185°F) ²	–20...+85°C (–4...+185°F)	–40...+85°C (–40...+185°F) ²	–40...+85°C (–40...+185°F) ²
Reference Accuracy	<ul style="list-style-type: none"> – Up to ±0.075% of the set span – PLATINUM version: up to ±0.05% of the set span 			<ul style="list-style-type: none"> – Up to ±0.075 % of the set span 	
Supply voltage	<ul style="list-style-type: none"> – For non-hazardous areas: 10.5...45 V DC – EEx ia: 10.5...30 V DC 				
Output	4...20 mA with superimposed HART protocol, PROFIBUS PA or FOUNDATION Fieldbus				
Options	<ul style="list-style-type: none"> – High-pressure version up to p_{stat} 700 bar – PMD75, FMD77, FMD78: Gold-Rhodium-coated diaphragm, NACE-compliant materials 				
Specialities (options)	<ul style="list-style-type: none"> – Metal-free measurement with PVDF flange – Available with Deltatop/Deltaset as flow compact device 	<ul style="list-style-type: none"> – p_{stat} up to 420 bar – Diaphragm: tantalum – Available with Deltatop/Deltaset as flow compact device 	<ul style="list-style-type: none"> – Abrasion-resistant and corrosion-resistant – No diaphragm-seal temperature effects – Metal-free measurement possible with ECTFE-coated process connection 	<ul style="list-style-type: none"> – For high media temperatures 	<ul style="list-style-type: none"> – Wide range of diaphragm seals

1) dependent on the lowest-rated element, with regard to pressure, of the selected components

2) lower temperature on request

**Overview of diaphragm seal
FMD78**

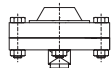
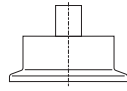
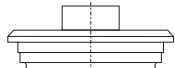
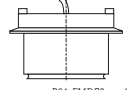
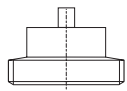
Design	Diaphr. seal	Connection	Version	Standard	Nominal diameter	Nom. press./Class	
Cell	Membrane diaphragm seal (MDM)	DIN cell		DIN 2501	– DN 50 – DN 80 – DN 100	PN 16 – 400	
		ANSI cell	P01-FMD78xxx-04-xx-xx-xx-000	ANSI B 16.5	– 2" – 3" – 4"	150 – 2500 lbs	
Threaded connection with separator	Membrane diaphragm seal (MDM)	G		ISO 228	G 1/2 B	PN 40	
		NPT	P01-FMD78xxx-03-xx-xx-xx-010	ANSI	1/2 NPT	PN 40	
Tri-Clamp	Membrane diaphragm seal (MDM)	Clamp		ISO 2852	– DN 25 (1") – DN 38 (1 1/2") – DN 51 (2") – DN 76.1 (3")	Dependent on the clamp used	
	Pipe diaphragm seal (RDM)	Clamp	P01-FMD78xxx-03-xx-xx-xx-005	ISO 2852	– DN 25 (1") – DN 38 (1 1/2") – DN 51 (2")	Dependent on the clamp used	
Hygienic connections	Membrane diaphragm seal (MDM)	Varivent			Type N for pipes DN 40 – DN 162	PN 40	
		DRD	P01-FMD78xxx-03-xx-xx-xx-007		d = 65 mm	25 bar	
		Sanitary tank spud with 2" extended diaphragm seal				d = 100 mm	Dependent on the clamp used
		Taper adapter with coupling nut	P01-FMD78xxx-03-xx-xx-xx-008	DIN 11851	– DN 50 – DN 65 – DN 80	PN 25	
		Threaded adapter		P01-FMD78xxx-03-xx-xx-xx-003	DIN 11851	– DN 50 – DN 65 – DN 80	PN 25

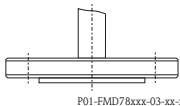
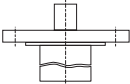
Design	Diaphr. seal	Connection	Version	Standard	Nominal diameter	Nom. press./Class
Flange	Membrane diaphragm seal (MDM)	EN/DIN flange	 P01-FMD78xxx-03-xx-xx-xx-001	EN 1092-1/ DIN 2527	– DN 50 – DN 80 – DN 100	Up to 40 bar
		ANSI flange		ANSI B 16.5	– 2" – 3" – 4"	150 lbs and 300 lbs
		JIS flange		B 2220	– 50 A – 80 A – 100 A	10 K
Flange with extended diaphragm seal	Membrane diaphragm seal (MDM)	ANSI flange	 P01-FMD78xxx-03-xx-xx-xx-002	ANSI B 16.5	– 3" with 2"/4"/6"/ 8" extended diaphragm seal – 4" with 2"/4"/6"/ 8" ext. diaphr. seal	150 lbs

Measuring principle

Ceramic measuring diaphragms used for PMD70 and FMD76

Metallic measuring diaphragms used for PMD75, FMD77 and FMD78

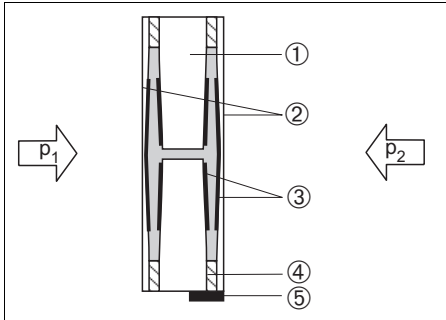

P01-xMD7xxxx-03-xx-xx-xx-000

Ceramic measuring cell PMD70 and FMD76

- | | |
|---|--|
| 1 | Meter body |
| 2 | Diaphragm |
| 3 | Electrodes |
| 4 | Glass frit fixes the diaphragm onto the meter body |
| 5 | Temperature sensor |

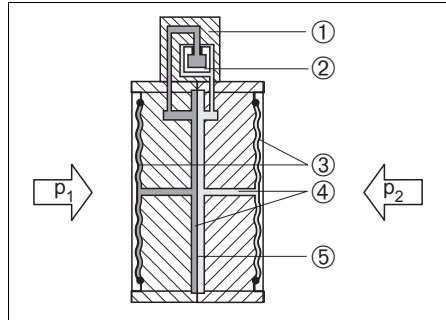

P01-xMD7xxxx-03-xx-xx-xx-002

Metal measuring cell 10 mbar and 30 mbar

- | | |
|---|--------------------------------|
| 1 | Sensing element |
| 2 | Silicon diaphragm |
| 3 | Separating diaphragm |
| 4 | Filling oil |
| 5 | Integrated overload protection |

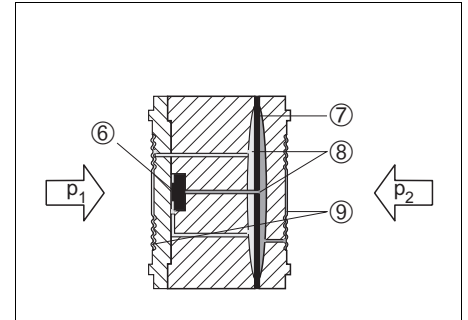

P01-xMD7xxxx-03-xx-xx-xx-003

Metal measuring cell as of 100 mbar

- | | |
|---|-------------------------------------|
| 6 | Sensing element |
| 7 | Overload diaphragm/Middle diaphragm |
| 8 | Filling oil |
| 9 | Separating diaphragm |

Ceramic measuring diaphragms used for PMD70 and FMD76

The ceramic measuring cell is based on the principle of a plate capacitor with an electrode on (1) and a movable electrode on the interior of the diaphragm (3). Standard silicone oil or mineral oil filling oils for this measuring cell.

A differential pressure ($p_1 \neq p_2$) causes a corresponding deflection of both diaphragms. Both capacitance values are converted and are fed to the microprocessor of the transmitter as a digital signal.

Advantages:

- Self-monitoring for diaphragm break or oil loss (constant comparison of the measured temperature with a temperature calculated from the capacitance values)
- Extremely high resistance to aggressive media
- Suitable for vacuums up to 1 mbar_{abs}
- Metal-free versions available
- Second process barrier (Secondary Containment) for enhanced integrity

Metallic measuring diaphragms used for PMD75, FMD77 and FMD78

The separating diaphragms (3/9) are deflected on both sides by the acting pressures. A filling oil (4/8) transfers the pressure to a resistance circuit bridge (semi-conductor technology). The differential-pressure-dependent change of the bridge output voltage is measured and further processed.

Advantages:

- Standard operating pressures: 160 bar and 420 bar
- High long-term stability
- Very high single-sided overload resistance
- Second process barrier (Secondary Containment) for enhanced integrity

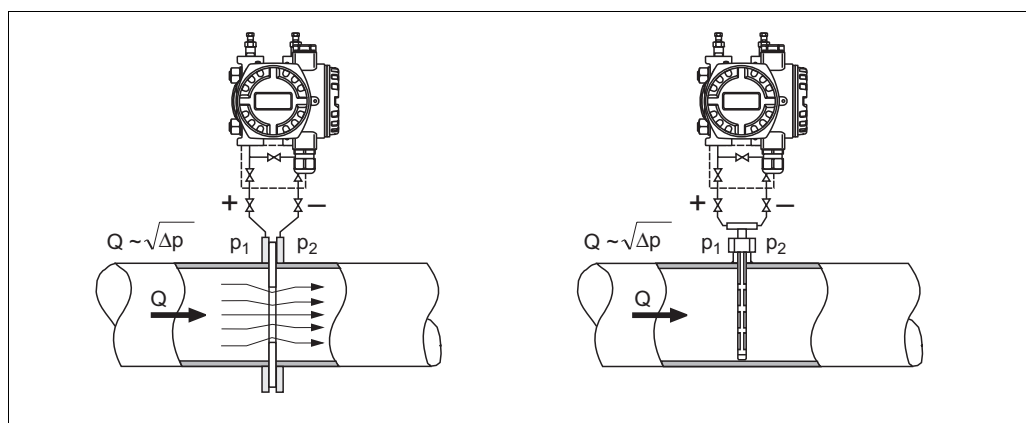

P01-PMD7xxxx-15-xx-xx-xx-000

Flow measurement with Deltabar S and primary element, left: Orifice plate and right: Pitot tube

Q Flow

Δp Differential pressure, $\Delta p = p_1 - p_2$

Your benefits

- Choice of four flow modes of operation: volume flow, norm volume flow (European norm conditions), standard volume flow (American standard conditions) and mass flow.
- Choice of diverse flow units with automatic unit conversion.
- A customised unit can be specified
- Low flow cut off: when activated, this function suppresses small flows which can lead to large fluctuations in the measured value.
- Contains two totalizers as standard. One totalizer can be reset to zero.
- The totalizing mode and unit can be individually set for each totalizer. This allows independent daily and annual quantity totalizing.
- With the product families Deltatop and Deltaset, Endress+Hauser is offering two universal and reliable solutions for flow measurement:
 - Deltatop, the compact, ready-to-use flow measuring unit including differential pressure transmitter Deltabar S
 - Deltaset with differential pressure transmitter Deltabar S, the modular flow measuring unit suitable for medium temperatures up to 1000°C (1832°F) and pressures up to 400 bar

Note: For more information about flow measurement with the Deltabar S differential pressure transmitter and orifice plate or pitot tube, see Technical Information TI297P Deltatop/Deltaset.

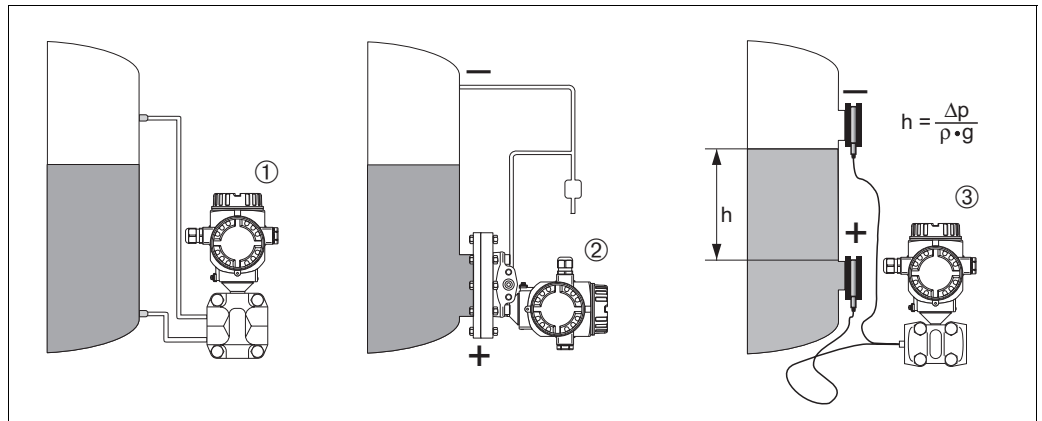
Level measurement (level, volume and mass)
Design and operation mode

Level measurement with Deltabar S

- 1 Level measurement via impulse piping and PMD70
 2 Level measurement with FMD76
 3 Level measurement with FMD78
h Height (level)
 Δp Differential pressure
 ρ Density of the medium
 g Gravitation constant

Your benefits

- Choice of three level operating modes
- Volume and mass measurements in any tank shapes by means of a freely programmable characteristic curve
- Choice of diverse level units with automatic unit conversion
- A customised unit can be specified
- Has a wide range of uses, e.g.
 - for level measurement in tanks with superimposed pressure
 - in the event of foam formation
 - in tanks with agitators or screen fittings
 - in the event of liquid gases
 - for standard level measurement

Communication protocol

- 4...20 mA with HART communication protocol
- PROFIBUS PA
 - The Endress+Hauser devices meet the requirements as per the FISCO model.
 - Due to the low current consumption of $11 \text{ mA} \pm 1 \text{ mA}$
 - up to 9 Deltabar S for EEx ia, CSA IS and FM IS applications
 - up to 32 Deltabar S for all other applications, e.g. in non-hazardous areas, EEx nA, etc. can be operated at one bus segment with installation as per FISCO.
 Further information on PROFIBUS PA, such as requirements for bus system components, can be found in the Operating Instructions BA034S "PROFIBUS DP/PA: Guidelines for planning and commissioning" and in the PNO guideline.
- FOUNDATION Fieldbus
 - The Endress+Hauser devices meet the requirements as per the FISCO model.
 - Due to the low current consumption of $14 \text{ mA} \pm 1 \text{ mA}$
 - up to 7 Deltabar S for EEx ia, CSA IS and FM IS applications
 - up to 30 Deltabar S for all other applications, e.g. in non-hazardous areas, EEx nA, etc. can be operated at one bus segment with installation as per FISCO.
 Further information on FOUNDATION Fieldbus, such as requirements for bus system components can be found in the Operating Instructions BA013S "FOUNDATION Fieldbus Overview".

Human interface

On-site display (optional)

A 4-line liquid crystal display (LCD) is used for display and operation. The on-site display shows measured values, dialog text as well as fault and notice messages in plain text, thereby supporting the user in every stage of operation.

4...20 mA HART

Functions:

- 8-digit measured value display including sign and decimal point, bargraph for current display
- Simple and complete menu guidance thanks to separation of the parameters into three levels
- Each parameter is given a 3-digit ID number for easy navigation.
- Option for configuring the display according to individual requirements and desires, such as language, alternating display, display of other measured values such as sensor temperature, contrast setting
- Comprehensive diagnostic functions (fault and warning message, peak-hold indicators, etc.)
- rapid and safe commissioning with the Quick Setup menus

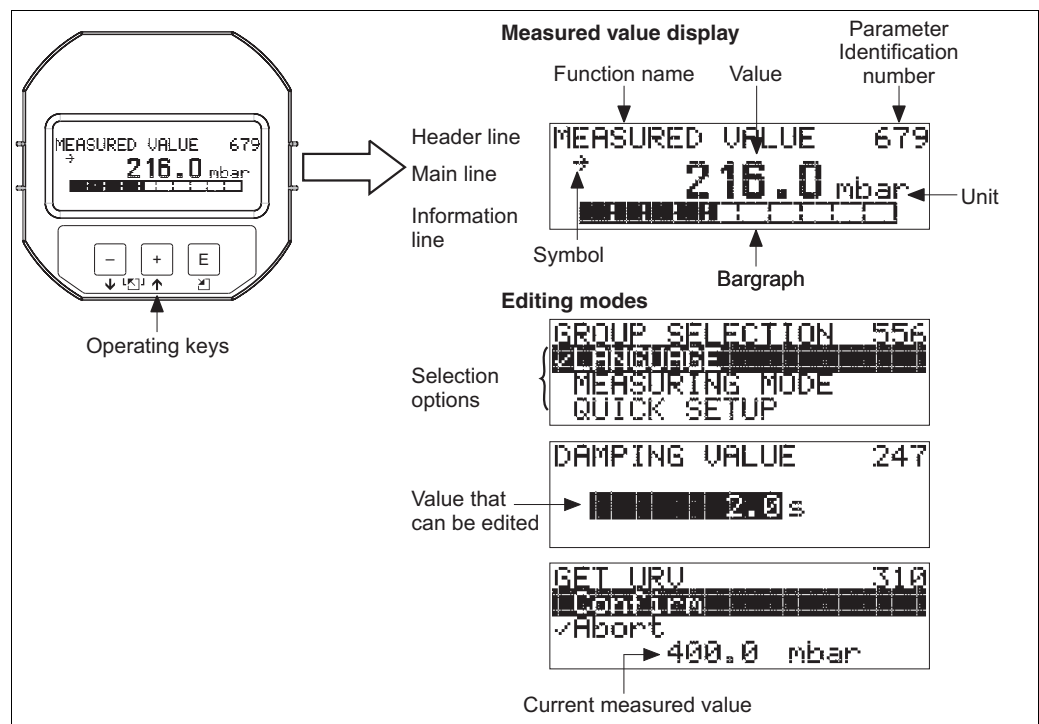

P01-xMx7xxxx-07-xx-xx-xx-001

PROFIBUS PA and FOUNDATION Fieldbus

Functions:

- 8-digit measured value display including sign and decimal point, bargraph for current display
- Option for configuring the display according to individual requirements and desires, such as language, alternating display, display of other measured values such as sensor temperature, contrast setting
- Comprehensive diagnostic functions (fault and warning message)

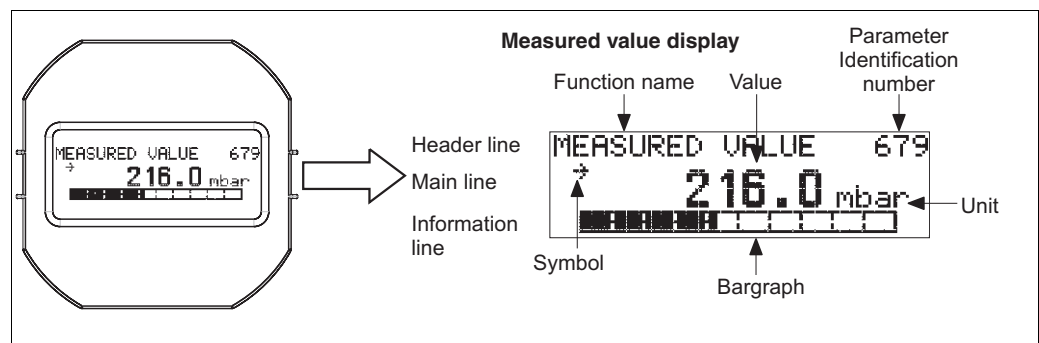

P01-xMD7xxxx-07-xx-xx-xx-001

Operating elements

With regard to T14 and T15 housings, the operating keys are located either outside the device under the protection cap or inside on the electronic insert. In T17 housings, the operating keys are always located inside on the electronic insert.
 In addition, devices with an on-site display and a 4 to 20 mA HART electronic insert have operating keys on the on-site display.

Operating keys on the exterior of the device

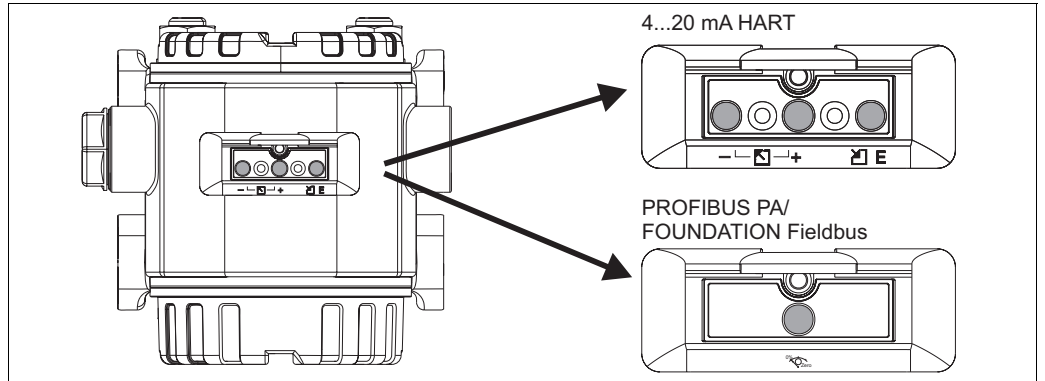

P01-xxxxxxx-19-xx-xx-xx-038

The operating keys located externally on the device work on the Hall sensor principle. As a result, no additional openings are required in the device. This guarantees:

- Complete protection against environmental influences such as moisture and contamination
- Simple operation without any tools
- No wear.

Operating keys and elements located internally on the electronic insert

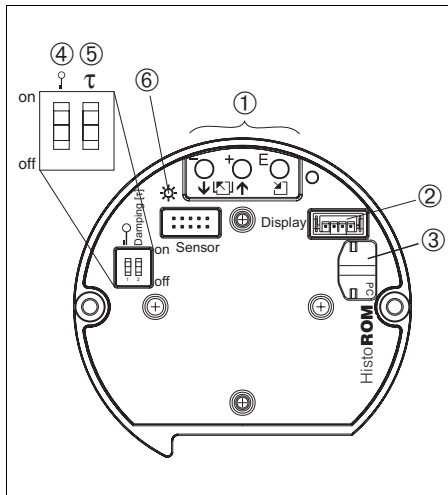

P01-xxxxxxx-19-xx-xx-xx-104

Electronic insert HART

- 1 Operating keys
- 2 Slot for optional display
- 3 Slot for optional HistoROM®/M-DAT
- 4 DIP-switch for locking/unlocking measured-value-relevant parameters
- 5 DIP-switch for damping on/off
- 6 Green LED to indicate value being accepted

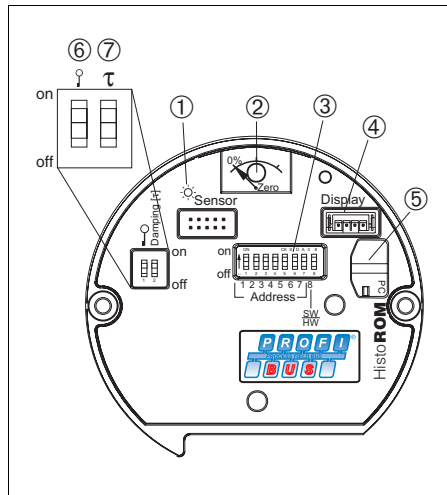

P01-xxxxxxx-19-xx-xx-xx-105

Electronic insert PROFIBUS PA

- 1 Green LED to indicate value being accepted
- 2 Key for position calibration
- 3 DIP-switch for bus address
- 4 Slot for optional display
- 5 Slot for optional HistoROM®/M-DAT
- 6 DIP-switch for locking/unlocking measured-value-relevant parameters
- 7 DIP-switch for damping on/off

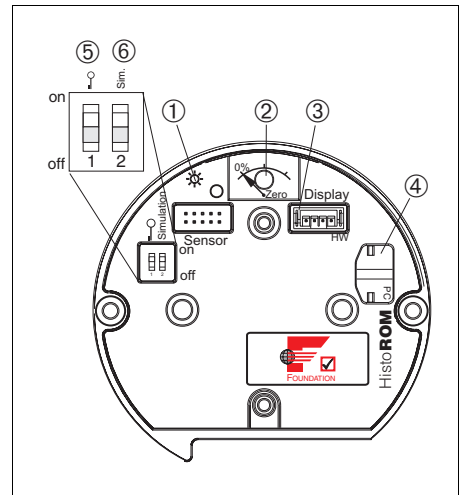

P01-xxxxxxx-19-xx-xx-xx-106

Electronic insert FOUNDATION Fieldbus

- 1 Green LED to indicate value being accepted
- 2 Key for position calibration
- 3 Slot for optional display
- 4 Slot for optional HistoROM®/M-DAT
- 5 DIP-switch for locking/unlocking measured-value-relevant parameters
- 6 DIP-switch for simulation mode on/off

**HistoROM®/M-DAT
(optional)**

HistoROM®/M-DAT is a memory module, which is attached to the electronic insert. The HistoROM®/M-DAT can be retrofitted at any stage (Order number: 52027785).

Your benefits

- Quick and safe commissioning of the same measuring points by copying the configuration data of one transmitter to another transmitter
- Reliable process monitoring thanks to cyclical recording of pressure and sensor temperature measured values
- Simple diagnosis by recording diverse events such as alarms, configuration changes, counters for measuring range undershoot and overshoot for pressure and temperature as well as user limit overshoot and undershoot for pressure and temperature etc.
- Analysis and graphic evaluation of the events and process parameters via ToF Tool (contained in scope of supply)

HistoROM®/M-DAT can be ordered via feature 100 "Additional options 1" or feature 110 "Additional options 2" or as spare parts. → See also page 64 ff. A CD with the Endress+Hauser ToF Tool operating program is also included in the scope of delivery.

You can copy data from one transmitter to another transmitter when operating a FOUNDATION Fieldbus device via an FF configuration program. You need the Endress+Hauser ToF Tool operating program and the FXA193 service interface to be able to access the data and events saved in the HistoROM®/M-DAT.

**Functional Safety SIL2/
IEC 61508 Declaration of
conformity (optional)**

The Deltabar S differential pressure transmitters with 4...20 mA output signal have been developed to IEC 61508 standard and have been certified by TÜV SÜD. These devices can be used for flow and differential pressure monitoring up to SIL 2.

→ For a detailed description of the safety functions with Deltabar S, settings and characteristic quantities for functional safety, please refer to the "Manual for Safety Manual - Deltabar S" SD189P.

→ For devices with SIL2/IEC 61508 declaration of conformity, see page 65 ff, Feature 100 "Additional option 1" and Feature 110 "Additional option 2", version E "SIL2/IEC 61508, Declaration of Conformity".

On-site operation**Functions 4...20 mA HART**

- With on-site display: navigate through the operating menu using three operating keys
- Without on-site display:
 - Position calibration (zero point correction)
 - Setting lower-range value and upper-range value – reference pressure present at device
 - Value acceptance indicated by green LED
- Device reset
- Locking and unlocking measured-value-relevant parameters
- Switching damping on and off

Functions PROFIBUS PA

- Position calibration (zero point correction)
- Value acceptance indicated by green LED
- Locking and unlocking measured-value-relevant parameters
- Setting bus address
- Switching damping on and off

Functions FOUNDATION Fieldbus

- Position calibration (zero point correction)
- Value acceptance indicated by green LED
- Locking and unlocking measured-value-relevant parameters
- Switching simulation mode on and off

Handheld terminals – HART

With a handheld terminal, all the parameters can be configured anywhere along the 4...20 mA line via menu operation.

**Handheld terminal DXR375 –
FOUNDATION Fieldbus**

With a handheld terminal DXR375, all the parameters can be configured via menu operation.

**ToF Tool –
HART, PROFIBUS PA,
FOUNDATION Fieldbus**

The ToF Tool is a graphic and menu-guided operating program for measuring devices from Endress+Hauser. It is used for the commissioning, data storage, signal analysis and documentation of the devices. The following operating systems are supported: WinNT4.0, Win2000 and Windows XP. You can set all parameters via the ToF Tool.

The ToF Tool supports the following functions:

- Configuration of transmitters in online operation
- Loading and saving device data (upload/download)
- HistoROM®/M-DAT analysis
- Calculation of tank characteristics for the level measuring mode
- Documentation of the measuring point

Connection options:

- HART via Commubox FXA191 and the serial interface RS 232 C of a computer
- HART via Commubox FXA195 and the USB interface of a computer
- PROFIBUS PA via segment coupler and PROFIBUS interface card
- FOUNDATION Fieldbus, PROFIBUS PA and HART: Service interface with adapter FXA193



Note!

You can use the ToF Tool to configure the Endress+Hauser parameters for devices with "FOUNDATION Fieldbus signal". You need an FF configuration program to be able to configure all the FF-specific parameters and to integrate the device into an FF network.

**FieldCare –
HART, PROFIBUS PA**

FieldCare is an Endress+Hauser asset management tool based on FDT technology. With FieldCare, you can configure all Endress+Hauser devices as well as devices from other manufacturers that support the FDT standard. The following operating systems are supported: WinNT4.0, Win2000 and Windows XP.

FieldCare supports the following functions:

- Configuration of transmitters in online operation
- Loading and saving device data (upload/download)
- HistoROM®/M-DAT analysis
- Documentation of the measuring point

Connection options:

- HART via Commubox FXA195 and the USB interface of a computer
- PROFIBUS PA via segment coupler and PROFIBUS interface card

**Remote operation –
FOUNDATION Fieldbus**

An FF configuration program is required to integrate a device with "FOUNDATION Fieldbus signal" into an FF network or to set the FF-specific parameters. Please contact your local Endress+Hauser Sales Center for more information.

Service interface FXA193

The FXA193 service interface connects Cerabar S, Deltabar S, ToF and PROline measuring devices (level and flow measuring devices) with the RS 232 C serial interface of a PC and thus makes it possible to operate the measuring devices with the Endress+Hauser ToF Tool operating program. The FXA193 service interface is connected to the interface for the local display on the electronic insert. → See also graphics on page 11.

Input

Measured variable Differential pressure, from which flow (volume or mass current) and level (level, volume or mass) are derived

Measuring range PMD75, FMD77, FMD78 (with metallic measuring diaphragms)

Nominal value	Measurement limit		Span		MWP ¹	Overload ²		min. operating pressure ³	Versions in the order code	
	lower (LRL)	upper (URL)	recommended min./max.	minimum ⁵		on one side	on both sides		PN 160 ⁶	PN 420 ⁶
[mbar]	[mbar]	[mbar]	[mbar]	[mbar]	[bar]	[bar]	[bar]	[mbar _{abs}]		
10 ⁷	-10	+10	10/10	0.25	160	160	240	0.1	7B	-
30 ⁷	-30	+30	30/30	0.3	160	160	240	0.1	7C	-
100	-100	+100	25/100	1/5 ⁸	160	160	240	0.1	7D	-
500	-500	+500	33/500	5	160/420 ⁹	160/420	240/630	0.1	7F	8F
3000	-3000	+3000	200/3000	30	160/420 ⁹	160/420	240/630	0.1	7H	8H
16000	-16000	+16000	1066/16000	160	160/420 ⁹	160/420	240/630	0.1	7L	8L
40000	-40000	+40000	2666/40000	400	160/420 ⁹	"+"side: 160/420 ¹⁰	240/630	0.1	7M	8M

PMD70, FMD76 (with ceramic measuring diaphragms)

Nominal value	Measurement limit		Span		MWP ¹	Overload ²		Min. operating pressure ³	Versions in the order code ⁴
	lower (LRL)	upper (URL)	recommended min./max.	minimum ⁵		on one side	on both sides		
[mbar]	[mbar]	[mbar]	[mbar]	[mbar]	[bar]	[bar]	[bar]	[mbar _{abs}]	
25	-25	+25	25	0.25	10	10	15	1	7B
100	-100	+100	25/100	1	16	16	24	1	7D
500	-500	+500	33/500	5	100	100	150	1	7F
3000	-3000	+3000	200/3000	30	100	100	150	1	7H

- 1) The MWP (maximum working pressure; MWP = PN) for the measuring device depends on the weakest element of the components selected with regard to pressure, i.e. the process connection (→ see page 32 ff) has to be taken into consideration in addition to the measuring cell (→ see table above). Also observe pressure-temperature dependency. For the appropriate standards and further information, see page 31, "Pressure specifications" section.
- 2) The maximum pressure for the measuring device is dependent on the lowest-rated element, with regard to pressure, of the selected components. → See also page 31, section "Pressure specifications".
- 3) The minimum operating pressure indicated in the table applies to silicone oil under reference operating conditions.
Min. operating pressure at 85°C (185°F) for silicone oil: 10 mbar_{abs}.
FMD77 and FMD78: Min. operating pressure: 50 mbar_{abs}; observe also the pressure and temperature application limits of the selected filling oil on page 55.
For vacuum applications, please observe the installation instructions on Page 62 ff.
- 4) Versions in the order code → See also page 67 ff, feature 40 "Nominal range; PN"
- 5) minimum span that can be calibrated, Turn down > 100:1 on request
- 6) PN 160 versions with stainless steel A2 screws, PN 420 versions with stainless steel A4 M12 screws
PN 420 versions for PMD75 only.
- 7) PMD75 only
- 8) minimum span that can be calibrated for PMD75: 1 mbar; minimum span that can be calibrated for FMD77 and FMD78: 5 mbar
- 9) For PMD75 with CRN-approved process connections, the MWP is 315 bar.
- 10) "-" side: 100 bar

Explanation of terms

Explanation of the terms: Turn down (TD), set span and zero based span

Case 1:

- $| \text{Lower range value} | \leq | \text{Upper range value} |$

Example:

- Lower range value (LRV) = 0 mbar
- Upper range value (URV) = 100 mbar
- Nominal value (URL) = 500 mbar

Turn down:

- $\text{Nominal value} / | \text{Upper range value} | = 500 \text{ mbar} / 100 \text{ mbar}$
TD = 5:1

set span:

- $\text{Upper range value} - \text{Lower range value} = 100 \text{ mbar} - 0 \text{ mbar}$
set span = 100 mbar
This span is based on the zero point.

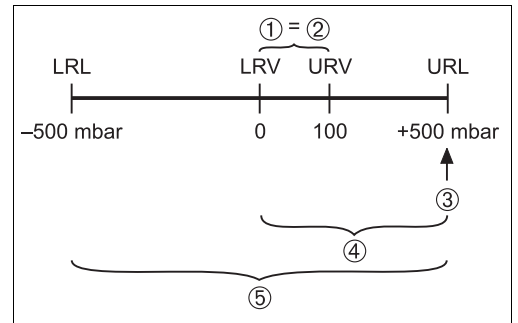

P01-xxxxxxx-05-xx-xx-xx-001

Example: 500 mbar sensor

Case 2:

- $| \text{Lower range value} | \geq | \text{Upper range value} |$

Example:

- Lower range value (LRV) = -300 mbar
- Upper range value (URV) = 0 mbar
- Nominal value (URL) = 500 mbar

Turn down:

- $\text{Nominal value} / | \text{Lower range value} | = 500 \text{ mbar} / 300 \text{ mbar}$
TD 1.67:1

set span:

- $\text{Upper range value} - \text{Lower range value} = 0 \text{ mbar} - (-300 \text{ mbar})$
set span = 300 mbar
This span is based on the zero point.

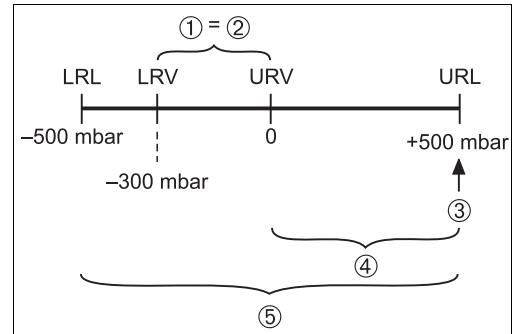

P01-IMD7xxxx-05-xx-xx-xx-007

Example: 500 mbar sensor

- 1 Set span
- 2 Zero based span
- 3 $\text{Nominal value} \cong \text{Upper range limit (URL)}$
- 4 Nominal measuring range
- 5 Sensor measuring range
- LRL Lower range limit
- URL Upper range limit
- LRV Lower range value
- URV Upper range value

Output

Output signal

- 4...20 mA with superimposed digital communication protocol HART 5.0, 2-wire
- Digital communication signal PROFIBUS PA (Profile 3.0)
- Digital communication signal FOUNDATION Fieldbus

Signal range – 4...20 mA HART

3.8 mA to 20.5 mA

Signal on alarm

- 4...20 mA HART
Options:
 - Max. alarm*: can be set from 21...23 mA
 - Keep measured value: last measured value is kept
 - Min. alarm: 3.6 mA
 - * Factory setting: 22 mA
- PROFIBUS PA: can be set in the Analog Input block,
options: Last Valid Out Value, Fsafe Value (factory setting), Status bad
- FOUNDATION Fieldbus: can be set in the Analog Input Block,
options: Last Good Value, Fail Safe Value (factory setting), Wrong Value

Load – 4...20 mA HART

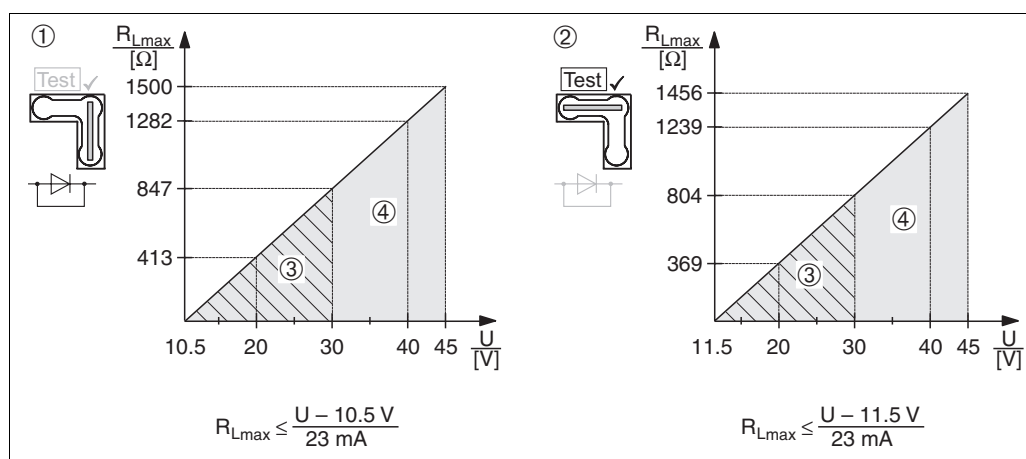

Load diagram, observe the position of the jumper and the explosion protection (→ See also page 20, section "Taking 4...20 mA test signal".)

- 1 Jumper for 4...20 mA test signal inserted in "Non-test" position
 - 2 Jumper for 4...20 mA test signal inserted in "Test" position
 - 3 Supply voltage 10,5 (11,5)...30 V DC for 1/2 D, 1 GD, 1/2 GD, FM IS, CSA IS, IECEx ia, NEPSI Ex ia and TIIS Ex ia
 - 4 Supply voltage 10,5 (11,5)...45 V DC for device for non-hazardous areas, 1/2 D, 1/3 D, 2 G EEx d, 3 G EEx nA, FM XP, FM DIP, FM NI, CSA XP, CSA Dust-Ex, NEPSI Ex d and TIIS Ex d
- R_{Lmax} Maximum load resistance
 U Supply voltage

Note!

When operating via a handheld terminal or via PC with an operating program, a minimum communication resistance of 250 Ω must exist within the loop.

Resolution

- Current output: 1 μA
- Display: can be set (setting at the factory: presentation of the maximum accuracy of the transmitter)

Reading cycle

- HART commands: on average 3 to 4 per second
- PROFIBUS PA:
 - cyclic:
 - max.: 100/s
 - typical value: 20/s
 - acyclic:
 - max.: 20/s
 - typical value: 10/s
- FOUNDATION Fieldbus:
 - cyclic: up to 5/s, dependent on the number and type of function blocks used in a closed-control loop
 - acyclic: 10/s

Cycle time (Update time)

- PROFIBUS PA
- The cycle time in a bus segment in cyclic data communication depends on the number of devices, on the segment coupler used and on the internal PLC cycle time.
 - The minimum cycle time is approx. 20 ms per device.

Response time

- PROFIBUS PA:
 - cyclic: approx. 10 ms per request
 - acyclic: < 50 ms
- FOUNDATION Fieldbus:
 - cyclic: < 80 ms
 - acyclic: < 40 ms

All values are typical values.

Damping

- Via on-site display, handheld terminal or PC with operating program, continuous from 0...999 s
- Additionally for HART and PROFIBUS PA: via DIP-switch on the electronic insert, switch position "on" = set value and "off"
- Factory setting: 2 s

Power supply

Electrical connection

Note!

- When using the measuring device in hazardous areas, installation must comply with the corresponding national standards and regulations and the Safety Instructions or Installation or Control Drawings. → See also page 78, section "Safety Instructions" and "Installation/Control Drawings".
- Devices with integrated overvoltage protection must be earthed. → See also page 30.
- Protective circuits against reverse polarity, HF influences and overvoltage peaks are installed.

4...20 mA HART

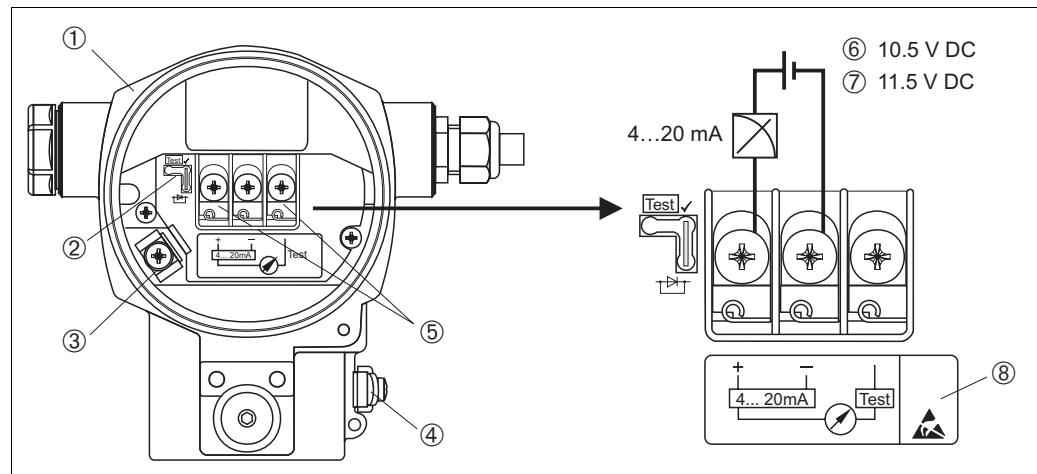

Electrical connection 4...20 mA HART

- 1 Housing
- 2 Jumper for 4...20 mA test signal. → See also page 20, section "Taking 4...20 mA test signal".
- 3 Internal earth terminal
- 4 External earth terminal
- 5 4...20 mA test signal between positive and test terminal
- 6 minimum supply voltage = 10.5 V DC, jumper is inserted in accordance with the illustration.
- 7 minimum supply voltage = 11.5 V DC, jumper is inserted in "Test" position.
- 8 Devices with integrated overvoltage protection are labelled OVP (overvoltage protection) here (→ see also page 30).

PROFIBUS PA

The two-wire cable must be connected to the "PA+" and "PA-" terminals.

FOUNDATION Fieldbus

The two-wire cable must be connected to the "FF+" and "FF-" terminals.

Devices with Harting plug Han7D

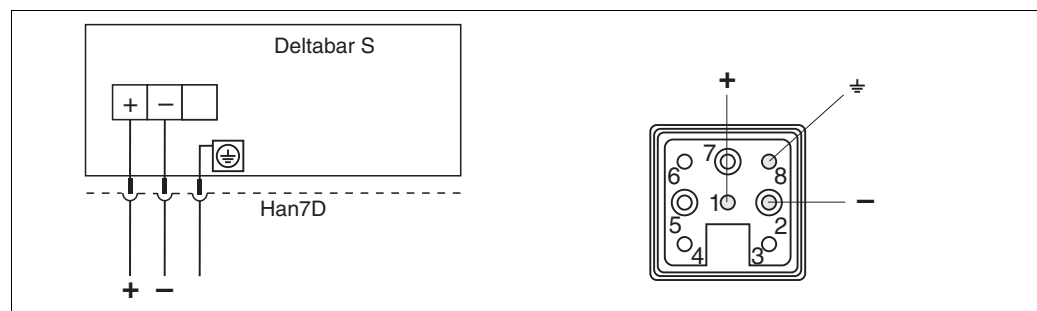

Left: electrical connection for devices with Harting plug Han7D
Right: view of the plug at the device

Devices with M12 plug

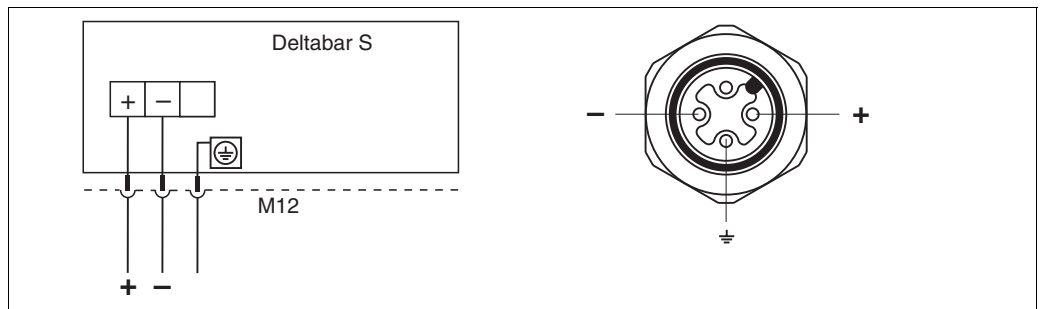

Left: electrical connection for devices with M12 plug
 Right: view of the plug at the device

P01-xMD7xxxx-04-xx-xx-xx-008

Endress+Hauser offers for devices with M12 plug the following accessories:

Plug-in jack M 12x1, straight

- Material: Body PA; coupling nut CuZn, nickel-plated
- Degree of protection (fully locked): IP67
- Order number: 52006263

Plug-in jack M 12x1, elbowed

- Material: Body PBT/PA; coupling nut GD-Zn, nickel-plated
- Degree of protection (fully locked): IP67
- Order number: 51006327

Cable 4x0.34 mm² with M12 socket, elbowed, screw plug, 5 m length

- Material: Body PUR; coupling nut CuSn/Ni; cable PVC
- Degree of protection (fully locked): IP67
- Order number: 52010285

Devices with 7/8" plug

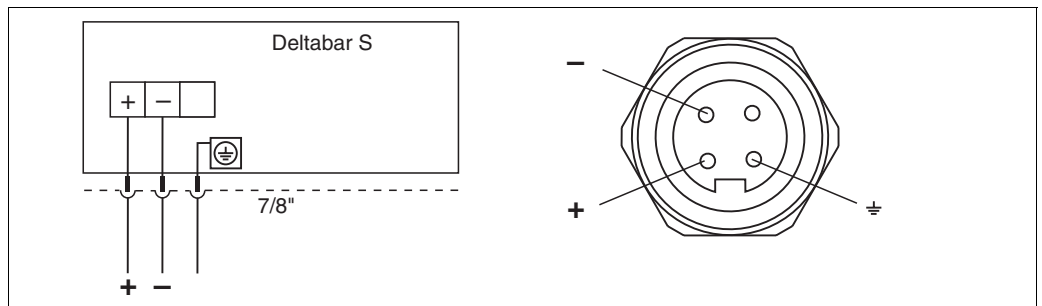



Left: electrical connection for devices with 7/8" plug
 Right: view of the plug at the device

P01-xMD7xxxx-04-xx-xx-xx-009

Taking 4...20 mA test signal

A 4...20 mA signal may be measured via the positive and test terminal without interrupting the measurement. The minimum supply voltage of the device can be reduced by simply changing the position of the jumper. As a result, operation is also possible with lower voltage sources. Observe the position of the jumper in accordance with the following table.

Jumper position for test signal	Description
	<ul style="list-style-type: none"> – Taking 4...20 mA test signal via plus and test terminal: possible. (Thus, the output current can be measured without interruption via the diode.) – Delivery status – minimum supply voltage: 11.5 V DC
	<ul style="list-style-type: none"> – Taking 4...20 mA test signal via plus and test terminal: not possible. – minimum supply voltage: 10.5 V DC

Supply voltage

Note!

- When using the measuring device in hazardous areas, installation must comply with the corresponding national standards and regulations and the Safety Instructions or Installation or Control Drawings.
- All explosion protection data are given in separate documentation which is available upon request. The Ex documentation is supplied as standard with all devices approved for use in explosion hazardous areas. → See also page 78, sections "Safety Instructions" and "Installation/Control drawing".

4...20 mA HART

- Version for non-hazardous areas, jumper for 4...20 mA test signal in "Test" position (delivery status): 11.5...45 V DC
- Version for non-hazardous areas, jumper for 4...20 mA test signal in "Non-test" position: 10.5...45 V DC

PROFIBUS PA

- Version for non-hazardous areas: 9...32 V DC

FOUNDATION Fieldbus

- Version for non-hazardous areas: 9...32 V DC

Current consumption

- PROFIBUS PA: 11 mA ± 1 mA, switch-on current corresponds to IEC 61158-2, Clause 21
- FOUNDATION Fieldbus: 14 mA ± 1 mA, switch-on current corresponds to IEC 61158-2, Clause 21

Cable entry

→ See also page 64 ff, feature 30 "Housing, Cable entry, Protection".

Cable specification

- Endress+Hauser recommends using shielded, twisted-pair two-wire cables.
- Terminals for wire cross-sections 0.5...2.5 mm²
- Cable external diameter: 5...9 mm

Residual ripple

Without influence on 4...20 mA signal up to ± 5 % residual ripple within the permitted voltage range [according to HART hardware specification HCF_SPEC-54 (DIN IEC 60381-1)]

Influence of power supply

≤ 0.0006% of URL/1 V

Performance characteristics – general

Reference operating conditions

- As per IEC 60770
- Ambient temperature $T_U = \text{constant}$, in the range of: $+21\dots+33^\circ\text{C}$ ($+69.8\dots+91.4^\circ\text{F}$)
- Humidity $\varphi = \text{constant}$, in the range of: 5...80 % r.H
- Ambient pressure $p_U = \text{constant}$, in the range of: 860...1060 mbar
- Position of the measuring cell: constant, in the range of: $\pm 1^\circ$
- Input of LOW SENSOR TRIM and HIGH SENSOR TRIM for lower range value and upper range value
- Zero based span
- Membrane material
 - PMD75: AISI 316L/1.4435, Alloy C276, Gold-Rhodium coated, Monel
 - FMD77, FMD78: AISI 316L/1.4435
 - PMD70, FMD76: Al_2O_3 (Aluminium-oxide-ceramic)
- Filling oil: silicone oil
- Side flanges material PMD75: AISI 316L/1.4435
- Supply voltage: 24 V DC \pm 3 V DC
- Load with HART: 250 Ω

Long-term stability

Measuring cells ≥ 500 mbar:

- $\pm 0.05\%$ of URL/year
- $\pm 0.125\%$ of URL/5 years

Measuring cells ≤ 100 mbar:

- $\pm 0.18\%$ of URL/year

Influence of the installation position

- PMD70, FMD76: ≤ 3 mbar ^{1, 3}
- PMD75: ≤ 4 mbar ^{1, 3}
- FMD77: ≤ 32 mbar ^{2, 3}

- 1) Device is rotated vertically to the membrane axis.
- 2) Device rotated vertically to the flange membrane.
- 3) The value is doubled for devices with inert oil.

Note!

Position-dependent zero shift can be corrected. → See also page 26, section "General installation instructions" and page 60 ff, section "Installation instructions, Diaphragm seal systems".

Vibration effects

Device	Housing	Test standard	Vibration effects
PMD70/ FMD76	optional on-site display on the side (T14)	GL	\leq reference accuracy to 10...18 Hz: ± 4 mm; 18...500 Hz: 5 g
PMD75	optional on-site display on the side (T14)	IEC 61298-3	\leq reference accuracy to 10...60 Hz: ± 0.35 mm; 60...2000 Hz: 5 g
PMD75	optional on-site display on the top (T15)		

Performance characteristics – metallic diaphragms

Reference accuracy – PMD75, FMD77, FMD78

The reference accuracy comprises the non-linearity including hysteresis and non-reproducibility in accordance with the limit point method as per IEC 60770.

The following applies for the root-extracting characteristic curve:
The accuracy data of the Deltabar S is taken into the accuracy calculation of the flow rate with a factor of 0.5.

PMD75, FMD77 and FMD78

10 mbar, 30 mbar measuring cells:

- TD 1:1: $\pm 0.15\%$ of the set span
- TD > 1:1: $\pm 0.15\%$ of the set span x TD

100 mbar measuring cell:

- TD 1:1 to TD 4:1: $\pm 0.075\%$ of the set span
- TD > 4:1: $\pm (0.012 \times \text{TD} + 0.027)\%$ of the set span

Measuring cells ≥ 500 mbar:

- TD 1:1 to TD 15:1: $\pm 0.075\%$ of the set span
- TD > 15:1: $\pm (0.0015 \times \text{TD} + 0.053)\%$ of the set span

Platinum version,

Measuring cells ≥ 100 mbar:

- TD 1:1: $\pm 0.05\%$ of the set span

Total performance – PMD75

The "Total performance" specification comprises the non-linearity including hysteresis, non-reproducibility, the thermal change of the zero point as well as the influence of the line pressure ($p_{st} = 70$ bar).

- AISI 316L/1.4435, Alloy, Gold-Rhodium coated or Monel membrane:
 $\pm 0.15\%$ of the set span ^{1,2}
- Tantalum membrane:
 $\pm 0.30\%$ of the set span ^{1,2}

1. for measuring ranges ≥ 500 mbar to TD 2:1
2. All specifications apply to the temperature range $-10\dots+60^\circ\text{C}$ ($+14\dots+140^\circ\text{F}$).

Warm-up period – PMD75, FMD77, FMD78

- 4...20 mA HART : < 10 s
- PROFIBUS PA: 6 s
- FOUNDATION Fieldbus: 50 s

Dead time, Time constant (T63) – PMD75, FMD77, FMD78

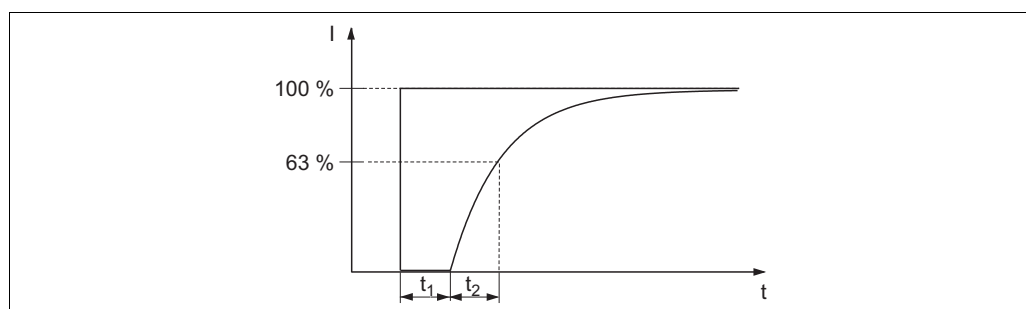

P01-xxxxxxx-05-xx-xx-xx-007

Presentation of the dead time and the time constant

Type	Dead time t_1	Time constant (T63), t_2
PMD75	45 ms	<ul style="list-style-type: none"> ■ 10 mbar and 30 mbar measuring cell: 200 ms ■ 100 mbar measuring cell: 60 ms ■ 500 mbar measuring cell: 45 ms ■ 3 bar measuring cell: 40 ms ■ 16 bar and 40 bar measuring cell: 60 ms
FMD77, FMD78	dependent on the diaphragm seal	

Influence of the operating pressure on zero point and span – PMD75, FMD77, FMD78

Measuring cell	AISI 316L/1.4435, Alloy, Gold-Rhodium coated or Monel membrane		Tantal membrane	
	Influence of the operating pressure on the zero point	Influence of the operating pressure on the span	Influence of the operating pressure on the zero point	Influence of the operating pressure on the span
10 mbar	±0.15 % of URL/7 bar	±0.035 % of URL/7 bar	±0.28 % of URL/7 bar	±0.28 % of URL/7 bar
30 mbar	±0.35 % of URL/70 bar	±0.14 % of URL/70 bar	±0.70 % of URL/70 bar	±0.70 % of URL/70 bar
100 mbar	±0.15 % of URL/70 bar	±0.14 % of URL/70 bar	±0.42 % of URL/70 bar	±0.42 % of URL/70 bar
500 mbar	±0.075 % of URL/70 bar	±0.14 % of URL/70 bar	±0.14 % of URL/70 bar	±0.14 % of URL/70 bar
3 bar	±0.075 % of URL/70 bar	±0.14 % of URL/70 bar	±0.14 % of URL/70 bar	±0.14 % of URL/70 bar
16 bar	±0.075 % of URL/70 bar	±0.14 % of URL/70 bar	±0.14 % of URL/70 bar	±0.14 % of URL/70 bar
40 bar	±0.075 % of URL/70 bar	±0.14 % of URL/70 bar	±0.14 % of URL/70 bar	±0.14 % of URL/70 bar

Note!

The influence of the operating pressure on the zero point can be calibrated out.

Thermal change of the zero output and the output span – PMD75

–10...+60°C (+14...+140°F)

AISI 316L/1.4435, Alloy, Gold-Rhodium coated or Monel membrane:

- 10 mbar, 30 mbar measuring cell: $\pm(0.31 \times TD + 0.06)\%$ of the set span
- 100 mbar measuring cell: $\pm(0.18 \times TD + 0.02)\%$ of the set span
- 500 mbar, 3 bar measuring cell: $\pm(0.08 \times TD + 0.05)\%$ of the set span
- 16 bar measuring cell: $\pm(0.1 \times TD + 0.1)\%$ of the set span
- 40 bar measuring cell: $\pm(0.08 \times TD + 0.05)\%$ of the set span

–10...+60°C (+14...+140°F)

Tantal membrane:

- 10 mbar, 30 mbar measuring cell: $\pm(0.31 \times TD + 0.06)\%$ of the set span
- 100 mbar measuring cell: $\pm(0.24 \times TD + 0.06)\%$ of the set span
- 500 mbar, 3 bar measuring cell: $\pm(0.08 \times TD + 0.05)\%$ of the set span
- 16 bar measuring cell: $\pm(0.1 \times TD + 0.1)\%$ of the set span
- 40 bar measuring cell: $\pm(0.08 \times TD + 0.05)\%$ of the set span

–40...–10°C, +60...+85°C (–40...+14°F, +140...+185°F)

all membrane materials:

- 10 mbar, 30 mbar measuring cell: $\pm(0.45 \times TD + 0.1)\%$ of the set span
- 100 mbar measuring cell: $\pm(0.3 \times TD + 0.15)\%$ of the set span
- 500 mbar, 3 bar measuring cell: $\pm(0.12 \times TD + 0.1)\%$ of the set span
- 16 bar measuring cell: $\pm(0.15 \times TD + 0.2)\%$ of the set span
- 40 bar measuring cell: $\pm(0.37 \times TD + 0.1)\%$ of the set span

Performance characteristics – ceramic diaphragms

Reference accuracy – PMD70, FMD76

The reference accuracy comprises the non-linearity including hysteresis and non-reproducibility in accordance with the limit point method as per IEC 60770.

The following applies for the root-extracting characteristic curve:
The accuracy data of the Deltabar S is taken into the accuracy calculation of the flow rate with a factor of 0.5.

25 mbar measuring cell:

- TD 1:1: $\pm 0.15\%$ of the set span
- TD > 1:1: $\pm 0.15\%$ of the set span x TD

100 mbar measuring cell:

- TD 1:1 to TD 4:1: $\pm 0.075\%$ of the set span
- TD > 4:1: $\pm (0.012 \times \text{TD} + 0.027)\%$ of the set span

500 mbar, 3 bar measuring cell:

- TD 1:1 to TD 15:1: $\pm 0.075\%$ of the set span
- TD > 15:1: $\pm (0.0015 \times \text{TD} + 0.05252)\%$ of the set span

Platinum version,

100 mbar, 500 mbar, 3bar measuring cells:

- TD 1:1: $\pm 0.05\%$ of the set span

Total performance – PMD70, FMD76

The "Total performance" specification comprises the non-linearity including hysteresis, non-reproducibility, the thermal change of the zero point as well as the influence of the line pressure ($p_{st} = 70 \text{ bar}$).

- $\pm 0.15\%$ of the set span ^{1, 2}

1. for measuring ranges $\geq 500 \text{ mbar}$, TD 1:1
2. All specifications apply to the temperature range $-10\dots+60^\circ\text{C}$ ($+14\dots+140^\circ\text{F}$).

Warm-up period – PMD70, FMD76

- 4...20 mA HART : < 10 s
- PROFIBUS PA: 6 s
- FOUNDATION Fieldbus: 50 s

Dead time, Time constant (T63) – PMD75, FMD77, FMD78

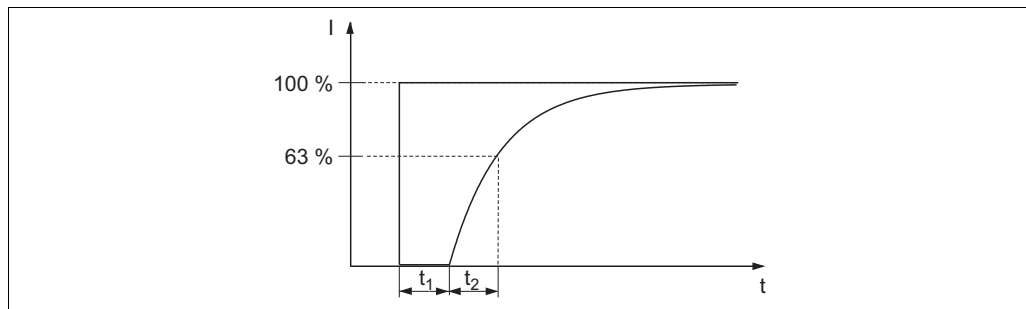

Presentation of the dead time and the time constant

Type	Dead time t_1	Time constant (T63), t_2
PMD70, FMD76	90 ms	<ul style="list-style-type: none"> ■ 25 mbar measuring cell: 4700 ms ■ 100 mbar measuring cell: 280 ms ■ 500 mbar measuring cell: 210 ms ■ 3 bar measuring cell: 110 ms

Influence of the operating pressure on zero point and span – PMD70, FMD76

Measuring cell	Influence of the operating pressure on the zero point	Influence of the operating pressure on the span
25 mbar	±0.7 % of URL/7 bar	±0.14 % of URL/7 bar
100 mbar	±0.175 % of URL/70 bar	±0.14 % of URL/70 bar
500 mbar	±0.075 % of URL/70 bar	±0.14 % of URL/70 bar
3 bar	±0.075 % of URL/70 bar	±0.14 % of URL/70 bar

Note!

The influence of the operating pressure on the zero point can be calibrated out.

Thermal change of the zero output and the output span – PMD70, FMD76

–10...+60°C (+14...+140°F):

- 25 mbar measuring cell: ±(0.35 x TD + 0.05)% of the set span
- ≥100 mbar measuring cells: ±(0.05 x TD + 0.05)% of the set span

–20...–10°C, +60...+85°C (–4...+14°F, +140...+185°F):

- 25 mbar measuring cell: ±(0.3 x TD + 0.15)% of the set span
- ≥ 100 mbar measuring cells: ±(0.08 x TD + 0.07)% of the set span

Operating conditions (Installation)

General installation instructions

- The position-dependent zero shift can be corrected directly at the device via operating key, for devices with external operation even in hazardous areas. Diaphragm seals also shift the zero point, depending on the installation position (→ See also page 61 ff, "Installation instructions, Diaphragm seal systems").
- The housing of the Deltabar S can be rotated up to 380°. → See also page 28, section "Turn the housing".
- Endress+Hauser offers a mounting bracket for installing the device on pipes or walls. → See also page 27, section "Wall- and pipe-mounting".
- When measuring in media with solid proportions, such as dirty liquids, installing separators and drain valves is useful for capturing and removing sediment.
- Using a three-valve or five-valve manifold allows for easy commissioning, installation and maintenance without interrupting the process.
- General recommendations for the impulse piping can be found in DIN 19210 "Methods for measurement of fluid flow; differential piping for flow measurement devices" or the corresponding national or international standards.
- Install the impulse piping with a continuous gradient of at least 10%.
- When routing the impulse piping outdoors, ensure that sufficient anti-freeze protection is used, e.g. by using pipe heat tracing.
- For FMD77 and FMD78: See page 61 ff, "Installation instructions, Diaphragm seal systems" section.

Measuring arrangement

Flow measurement

- The PMD70 and PMD75 are best suited to flow measurement.
- Measuring arrangement for gases: Mount device above the measuring point.
- Measuring arrangement for liquids and vapours: Mount device below tapping point.
- For flow measurement in vapours, mount the condensate traps at the same level as the same the tapping point and at the same distance from Deltabar S.

Level measurement

- PMD70, PMD75, FMD76 and FMD77 are best suited to level measurement in open tanks. All Deltabar S devices are suitable for level measurement in closed tanks.

Measuring arrangement level measurement in open tanks

- PMD70, PMD75: Mount device below the lower measuring connection. The negative side is open to atmosphere pressure.
- FMD76, FMD77: Mount device direct on the tank. The negative side is open to atmosphere pressure.

Measuring arrangement level measurement in closed tanks and closed tanks with superimposed vapour

- PMD70, PMD75: Mount device below the lower measuring connection. Always connect the negative side above the maximum level.
- FMD76, FMD77: Mount device direct on the tank. Always connect the negative side above the maximum level.
- In the case of level measurement in closed tanks with superimposed vapour, a condensate trap ensures pressure which remains constant on the minus side.

Pressure measurement

- The PMD70 and PMD75 are best suited to differential pressure measurement.
- Measuring arrangement for gases: Mount device above the measuring point.
- Measuring arrangement for liquids and steams: Mount device below tapping point.
- For differential pressure measurement in vapour, mount the condensate traps at the same level as the same the tapping point and at the same distance from Deltabar S.

Heat insulation – FMD77

The FMD77 must only be insulated up to a certain height. The maximum permitted insulation height is labelled on the devices and applies to an insulation material with a heat conductivity $\leq 0.04 \text{ W}/(\text{m} \times \text{K})$ and to the maximum permitted ambient and process temperature (→ see table below). The data were determined under the most critical application "quiescent air".

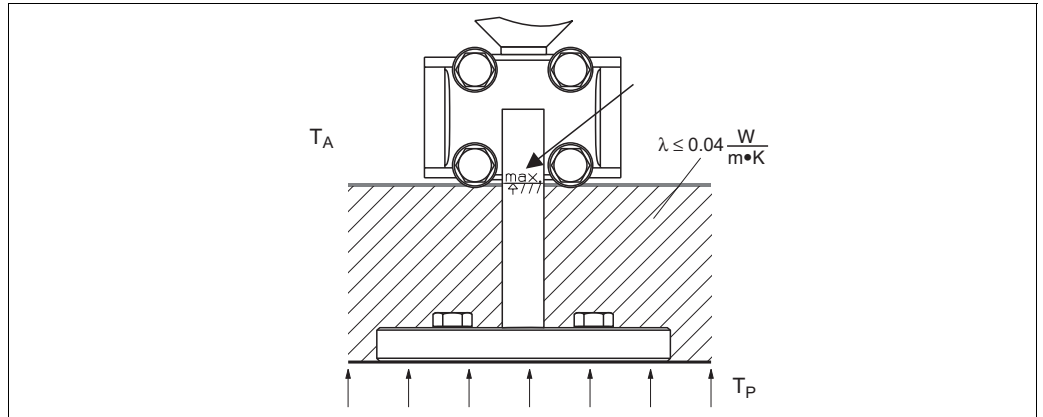

P01-FMD77xxxx-11-xx-xx-xx-000

Maximum permitted insulation height

	FMD77
Ambient temperature (T_A)	$\leq 70^\circ\text{C}$ (158°F)
Process temperature (T_P)	max. 350°C (662°F), depending on the diaphragm seal filling oil used (→ see page 55)

Wall- and pipe-mounting

Endress+Hauser offers a mounting bracket for installing the device on pipes or walls. → See also page 64 ff, feature 110, "Additional options 2".

Note!

If a valve block is used, its dimensions should also be taken into consideration.

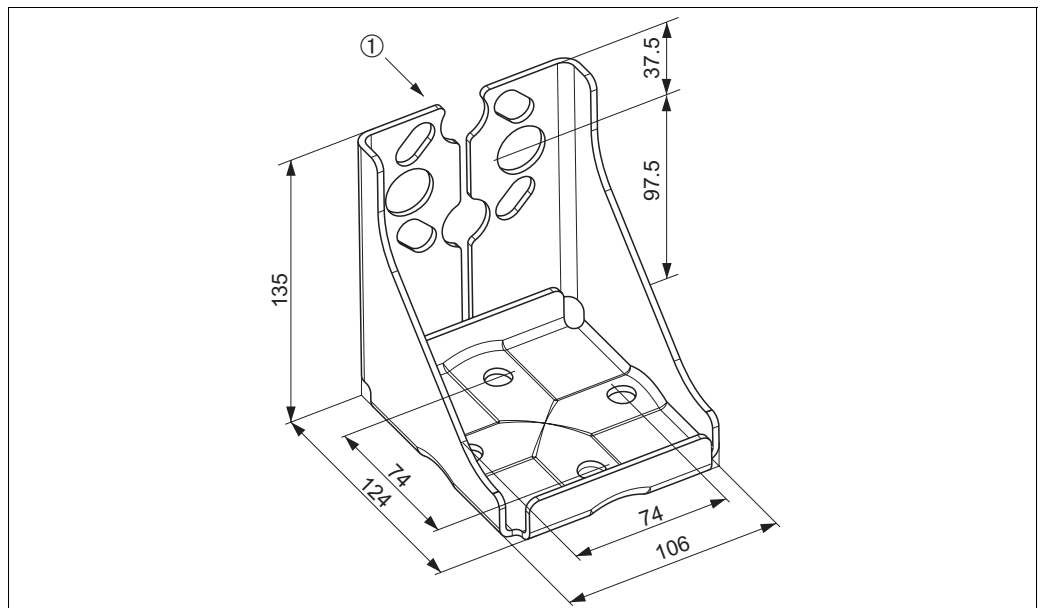

P01-xMD7xxxx-11-xx-xx-xx-008

Mounting bracket for wall and pipe-mounting

A bracket including mounting accessories for pipe mounting is included with the device.

1 Device mounting

Turn the housing

The housing can be rotated up to 380° by loosening the Allen screw.

Your benefits

- Simple mounting by optimally aligning the housing
- Good, accessible device operation
- Optimum readability of the on-site display (optional).

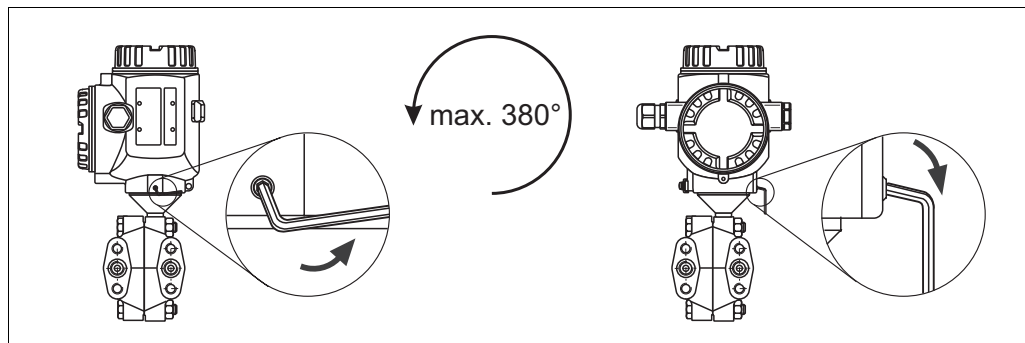

Align the housing by loosening the Allen screw.

T14 and T15 housing: 2 mm Allen key; T17 housing: 3 mm Allen key

Oxygen applications

Oxygen and other gases can react explosively to oils, grease and plastics, such that, among other things, the following precautions must be taken:

- All components of the system, such as measuring devices, must be cleaned in accordance with the BAM (DIN 19247) requirements.
- Dependent on the materials used, a certain maximum temperature and a maximum pressure for oxygen applications must not be exceeded.

The devices suitable for gaseous oxygen applications are listed in the following table with the specification p_{\max} .

Order code for devices cleaned for oxygen applications	p_{\max} for oxygen applications	T_{\max} for oxygen applications
PMD70 – * * * * * 2 * *, Devices with 500 mbar or 3000 mbar measuring cell	30 bar	60°C (140°F)
PMD70 – * * * * * 2 * *, Devices with 25 mbar or 100 mbar measuring cell	PN of the flange	60°C (140°F)
PMD75 – * * * * * K * *	160 bar	85°C (185°F)
PMD75 – * * * * * 2 * *	160 bar	60°C (140°F)
PMD75 – * * * * * 3 * *	160 bar	60°C (140°F)
FMD76 – * * * * * T * * *, Devices with 500 mbar or 3000 mbar measuring cell	30 bar	60°C (140°F)
FMD76 – * * * * * T * * *, Devices with 25 mbar or 100 mbar measuring cell	PN of the measuring cell	60°C (140°F)
FMD77 – * * * * * T * F * *	PN of the flange	60°C (140°F)
FMD78 – * * * * * 4 * * FMD78 – * * * * * D * *	90 bar	85°C (185°F)

Ultra pure gas applications

Endress+Hauser also offers degreased devices for special applications, such as ultra pure gas. No special restrictions regarding the process conditions apply to these devices.

→ See also page 64 ff, PMD70 and PMD75: feature 80 "Seal", FMD76 and FMD77: feature 70 "Process connection low-pressure side, material, seal".

Diaphragms for materials with hydrogen build-up (Gold-Rhodium coating) With regard to materials in which hydrogen build-up takes place, hydrogen atoms can diffuse through the metal diaphragms. This can result in incorrect measurement results.
 Endress+Hauser offers diaphragms with Gold-Rhodium coating for this application.
 → See also page 67 "Ordering information PMD75", page 73 "Ordering information FMD77" or page 76 "Ordering information FMD78", feature 60 "Membrane material".

Operating conditions (Environment)

Ambient temperature range

- PMD75, FMD77, FMD78: -40...+85°C (-40...+185°F), devices for lower temperatures on request
- PMD70, FMD76: -20...+85°C (-4...+185°F)
- On-site display: -20...+70°C (-4...+158°F)
 Extended temperature application range with restrictions in optical properties such as display speed and contrast: -40...+85°C (-40...+185°F)

For devices for use in hazardous areas, see Safety instructions, Installation or Control Drawing. (→ See also page 78, sections "Safety Instruction" and "Installation/Control drawings".)

The device can be used in this temperature range. The values of the specification, such as thermal change, may be exceeded. → See also DIN 16086.

Storage temperature range

- -40...+100°C (-40...+212°F)
- On-site display: -40...+85°C (-40...+185°F)

Degree of protection

- → See page 64 ff, feature 30 "Housing, Cable entry, Protection".
- Degree of protection IP 68 for T17 housing: 1.83 mH₂O for 24 h

Climate class Class 4K4H (air temperature: -20...55°C/-4...+131°F, relative humidity: 4...100%) fulfilled as per DIN EN 60721-3-4 (condensation possible)

Vibration resistance

Device/Additional option	Housing	Test standard	Vibration resistance
PMD70/ FMD76	optional on-site display on the side (T14)	GL	guaranteed for: 2...18 Hz: ±4 mm; 18...500 Hz: 5 g in all 3 planes
PMD75	optional on-site display on the side (T14)	IEC 61298-3	guaranteed for: 10...60 Hz: ±0.35 mm; 60...2000 Hz: 5 g in all 3 planes
PMD75	optional on-site display on the top (T15)		
with mounting bracket		IEC 61298-3	guaranteed for: 10...60 Hz: ±0.15 mm; 60...500 Hz: 2 g in all 3 plans

Electromagnetic compatibility

- Interference emission as per EN 61326 electrical device B, Interference immunity as per EN 61326 appendix A (industrial use) and NAMUR EMC recommendation (NE 21)¹.
- With increased interference immunity against electromagnetic fields as per EN 61000-4-3: 30 V/m with closed cover²
- Maximum deviation: < 0.5% of span
- All EMC measurements were performed with a turn down (TD) = 2:1.

1) Larger deviations possible with PMD70 with 25 mbar or 100 mbar sensor
 2) for devices with T14 or T15 housing

Overvoltage protection (optional)

- Overvoltage protection:
 - Nominal functioning DC voltage: 600 V
 - Nominal discharge current: 10 kA
- Surge current check $\hat{i} = 20$ kA as per DIN EN 60079-14: 8/20 μ s satisfied
- Arrester AC current check $I = 10$ A satisfied

→ See also page 65 ff, feature 100 "Additional options 1" and feature 110 "Additional options 2", version "M Overvoltage protection".

Note!

Devices with integrated overvoltage protection must be earthed.

Operating conditions (Process)

Process temperature limits

- PMD70: $-20\dots+85^{\circ}\text{C}$ ($-4\dots+185^{\circ}\text{F}$)
- FMD76: $-20\dots+85^{\circ}\text{C}$ ($-4\dots+185^{\circ}\text{F}$)
- PMD75 with impulse piping longer than 100 mm: $-40\dots+120^{\circ}\text{C}$ ($-40\dots+248^{\circ}\text{F}$),
with side flanges C22.8 and impulse piping longer than 100 mm: $-10\dots+120^{\circ}\text{C}$ ($14\dots+248^{\circ}\text{F}$)
- FMD77 and FMD78, depending on the diaphragm seal and filling oil: up to $+350^{\circ}\text{C}$ ($+662^{\circ}\text{F}$)

Note!

- For oxygen applications, observe page 28 "Oxygen applications" section.
- PMD70, FMD76, PMD75 and FMD78: Observe the temperature operating range of the seal.
→ See also the following section "Temperature operating range, seals".
- FMD77 and FMD78: Observe the temperature application limits of the diaphragm seal oil.
→ See also page 55, sections "Diaphragm seal filling oils".
- FMD77 and FMD78: Do not use diaphragm seals with 0.09 mm PTFE foil on AISI 316L (1.4435/1.4405) for vacuum applications, upper temperature limit $+205^{\circ}\text{C}$ ($+401^{\circ}\text{F}$).

Temperature operating range, seals**PMD70 (with ceramic measuring diaphragms)**

Versions for feature 80 in the order code	Seal	Temperature operating range
A	FKM Viton	$-20\dots+85^{\circ}\text{C}$ ($-4\dots+185^{\circ}\text{F}$)
B	EPDM	$-20\dots+85^{\circ}\text{C}$ ($-4\dots+185^{\circ}\text{F}$)
D	Kalrez, Compound 4079	$+5\dots+85^{\circ}\text{C}$ ($+41\dots+185^{\circ}\text{F}$)
E	Chemraz, Compound 505	$-20\dots+85^{\circ}\text{C}$ ($-4\dots+185^{\circ}\text{F}$)
1	FKM Viton, degreased	$-10\dots+85^{\circ}\text{C}$ ($+14\dots+185^{\circ}\text{F}$)
2	FKM Viton, cleaned for oxygen service	$-10\dots+60^{\circ}\text{C}$ ($+14\dots+140^{\circ}\text{F}$)

FMD76 (with ceramic measuring diaphragms)

Versions for feature 70 in the order code	Seal	Temperature operating range
B, D, F, G, U	FKM Viton	$-20\dots+85^{\circ}\text{C}$ ($-4\dots+185^{\circ}\text{F}$)
K, L	EPDM FDA 21 CFR 177.2600	$-20\dots+85^{\circ}\text{C}$ ($-4\dots+185^{\circ}\text{F}$)
M, N	Kalrez, Compound 4079	$+5\dots+85^{\circ}\text{C}$ ($+41\dots+185^{\circ}\text{F}$)
P, Q	Chemraz, Compound 505	$-20\dots+85^{\circ}\text{C}$ ($-4\dots+185^{\circ}\text{F}$)
S	FKM Viton, degreased	$-10\dots+85^{\circ}\text{C}$ ($+14\dots+185^{\circ}\text{F}$)
T	FKM Viton, cleaned for oxygen service	$-10\dots+60^{\circ}\text{C}$ ($+14\dots+140^{\circ}\text{F}$)

PMD75 (with metallic measuring diaphragms)

Versions for feature 80 in the order code	Seal	Temperature operating range ¹
A	FKM Viton	-20...+85°C (-4...+185°F)
C	PTFE	-40...+85°C (-40...+185°F)
F	NBR	-20...+85°C (-4...+185°F)
H	Copper	-40...+85°C (-40...+185°F)
K	Copper, cleaned for oxygen service	-20...+60°C (-4...+140°F)
1	FKM Viton, degreased	-10...+85°C (+14...+185°F)
2	FKM Viton, cleaned for oxygen service	-10...+60°C (+14...+140°F)
3	PTFE, cleaned for oxygen service	-20...+60°C (-4...+140°F)

1) lower temperature on request

FMD77 (with metallic measuring diaphragms)

Versions for feature 70 in the order code	Seal on the LP side (-)	Temperature operating range ¹
B, D, F, G	FKM Viton	-20...+85°C (-4...+185°F)
H, J	PTFE	-40...+85°C (-40...+185°F)
K, L	EPDM	-40...+85°C (-40...+185°F)
M, N	Kalrez, Compound 4079	+5...+85°C (+41...+185°F)
P, Q	Chemraz, Compound 505	-20...+85°C (-4...+185°F)
S	FKM Viton, degreased	-10...+85°C (+14...+185°F)
T	FKM Viton, cleaned for oxygen service	-10...+60°C (+14...+140°F)

1) lower temperature on request

Pressure specifications

- The MWP (maximum working pressure) is specified on the nameplate. The maximum pressure for the measuring device is dependent on the lowest-rated element with regard to pressure, see the following sections for this:
 - → page 14 ff, section "Measuring range"
 - → chapter "Mechanical construction".
 The MWP (maximum working pressure) is specified on the nameplate. This value refers to a reference temperature of 20°C (68°F) or 100°F for ANSI flanges. Observe pressure-temperature dependency.
- The pressure values permitted at higher temperatures can be found in the following standards:
 - EN 1092-1: 2001 Tab. 18 ¹
 - ASME B 16.5a – 1998 Tab. 2-2.2 F316
 - ASME B 16.5a – 1998 Tab. 2.3.8 N10276
 - JIS B 2220
- For PMD70 and PMD75, the MWP applies for the temperature ranges specified in the "Ambient temperature range" (→ page 29) and "Process temperature limits" (→ page 30) sections.
- The test pressure corresponds to the over pressure limit (OPL) of the device = MWP x 1.5.
- The Pressure Equipment Directive (EC Directive 97/23/EC) uses the abbreviation "PS". The abbreviation "PS" corresponds to the MWP (maximum working pressure) of the measuring device.
- In the case of sensor range and process connections where the OPL (Over pressure limit) of the pressure connection is smaller than the nominal value of the sensor, the device is set at the factory, at the very maximum, to the OPL value of the process connection. If you want to use the entire sensor range, select a process connection with a higher OPL value (1.5 x PN; PN = MWP).
- In oxygen applications, the values for "p_{max} and T_{max} for oxygen applications" as per page 28, "Oxygen applications" may not be exceeded.

1) With regard to its stability property, the material 1.4435 is identical to 1.4404 which is grouped under 13EO in EN 1092-1 Tab. 18. the chemical composition of the two materials can be identical.

Mechanical construction

Housing dimensions T14, optional display on the side

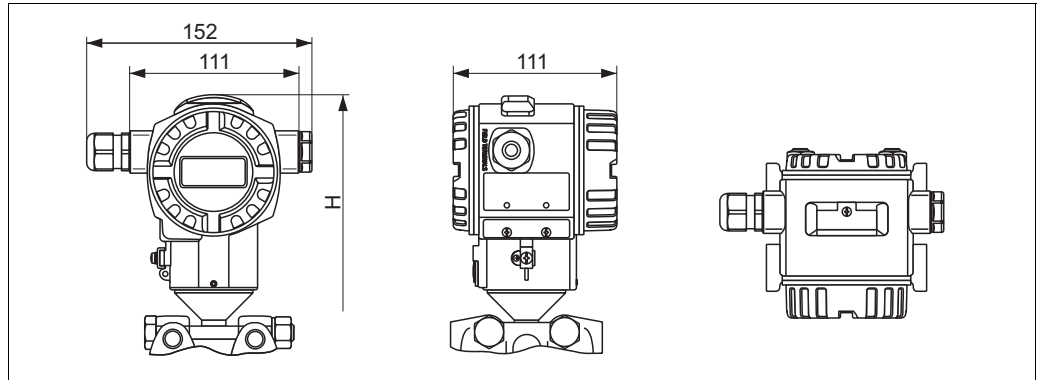

Front view, left-hand side view, top view

→ See the process connection in question for installation height. Housing weight see page 52.

Housing dimensions T15, optional display on the top

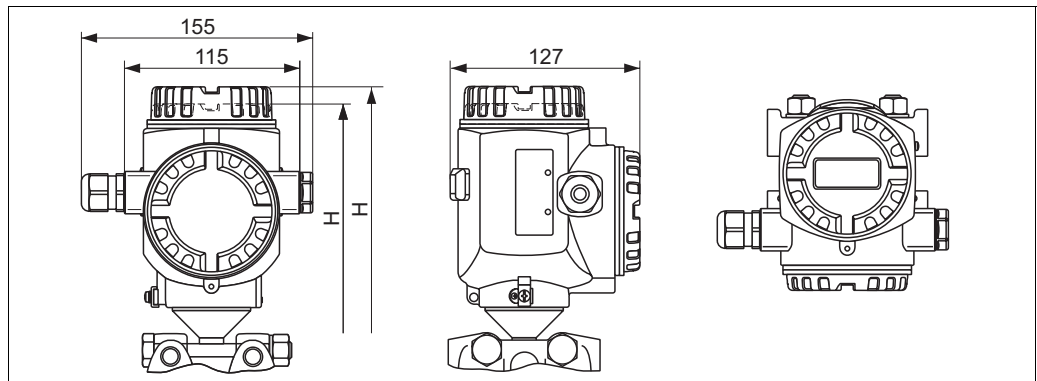

Front view, left-hand side view, top view

→ See the process connection in question for installation height. Housing weight see page 52.

Housing dimensions T17, optional display on the top

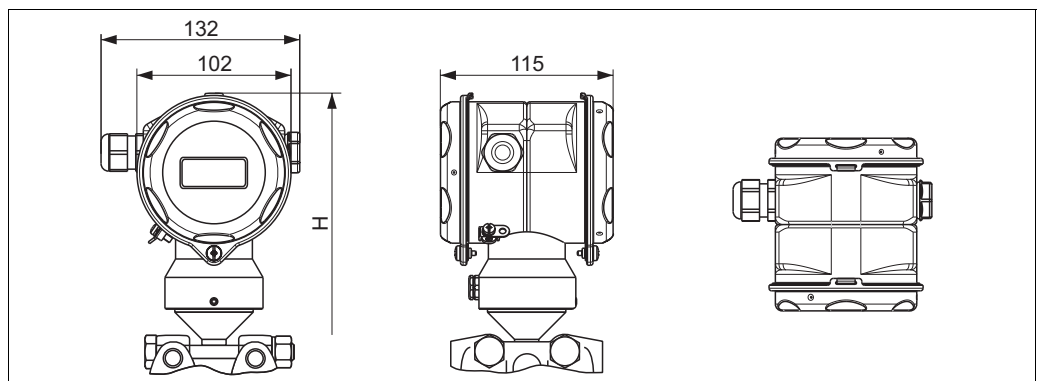

Front view, left-hand side view, top view

→ See the process connection in question for installation height. Housing weight see page 52.

**Process connections PMD70
(with ceramic measuring
diaphragms)**

Note!

Some device versions have CRN approval. For a CRN-approved device, a CRN-approved process connection (→ see page 65, feature 70 "Process connection") has to be ordered with a CSA approval (→ see page 64, feature 10 "Approval"). These devices are fitted with a separate plate bearing the registration number 0F10524.5C.

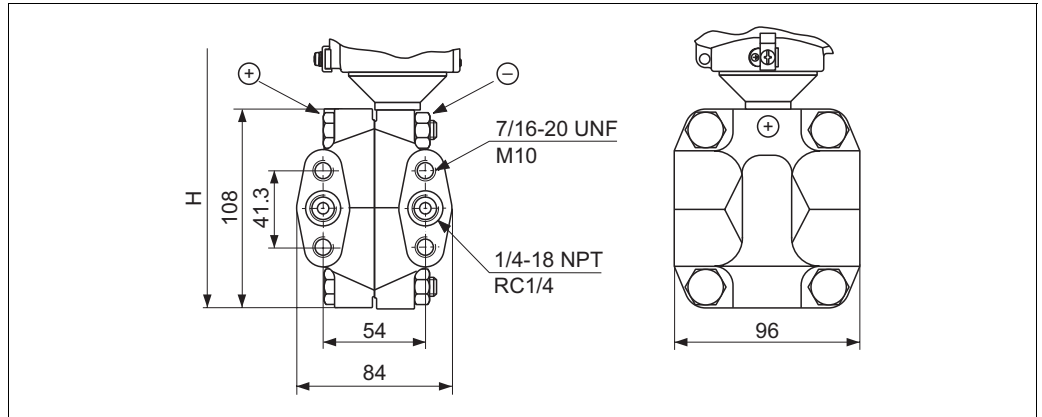

Process connection PMD70, oval flange

H Device height → see page 34, section "Device height H"

Ver- sion	Connection	Mounting	Material	Accessories	Weight ¹
B	1/4-18 NPT IEC 61518	7/16-20 UNF	Steel C 22.8	2 vent valves (AISI 316L/1.4404) included	4.0 kg
D	1/4-18 NPT IEC 61518	7/16-20 UNF	AISI 316L ²		4.0 kg
F	1/4-18 NPT IEC 61518	7/16-20 UNF	Alloy C276 ³	Vent valves (Alloy C276/2.4819), see page 65 feature 110 "Additional options 2".	4.2 kg
U	RC 1/4	7/16-20 UNF	AISI 316L ²	2 vent valves (AISI 316L/1.4404) included	4.0 kg
1	1/4-18 NPT IEC 61518	PN 160: M10	Steel C 22.8		4.0 kg
2	1/4-18 NPT IEC 61518	PN 160: M10	AISI 316L ²		4.0 kg
3	1/4-18 NPT IEC 61518	PN 160: M10	Alloy C276 ³	Vent valves (Alloy C276/2.4819), see page 65, feature 110 "Additional options 2".	4.2 kg

1) Process connection weight, for housing weight see page 52

2) AISI 316L/1.4435

3) Alloy C276/2.4819

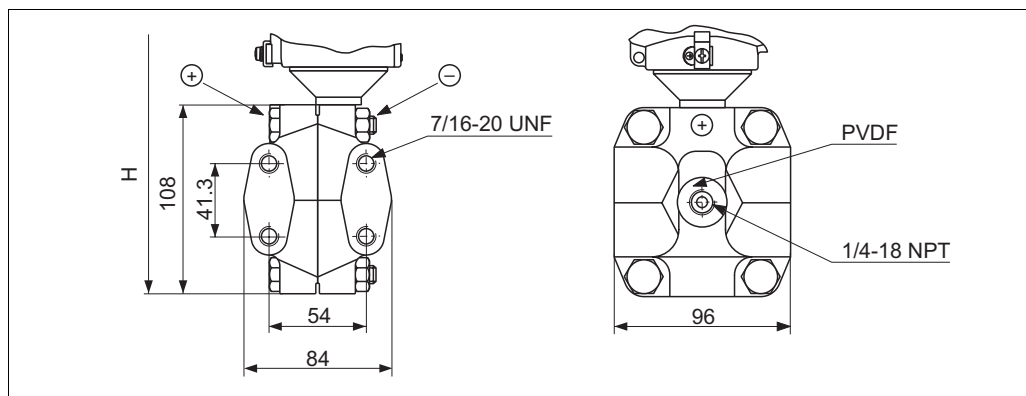

P01-PMD70xxx-06-09-xx-xx-001

Process connection PMD70, version G, PVDF inlay, PN = 10 bar, process temperature $T = -10...+60^{\circ}\text{C}$ ($14...+140^{\circ}\text{F}$)

H Device height → see page 34, section "Device height H "

Version	Connection	Mounting	Material	Weight ¹
G	1/4-18 NPT IEC 61518	7/16-20 UNF	PVDF	3.8 kg

1) Process connection weight, for housing weight see page 52

Device height H

Description	Device height H
T14 housing, optional display on the side	253 mm
T15 housing, optional display on the top, flat cover	259 mm
T15 housing, optional display on the top, high cover	270 mm
T17 housing, optional display on the side	269 mm

**Process connections PMD75
(with metallic measuring
diaphragms)**

Note!

Some device versions have CRN approval. For a CRN-approved device, a CRN-approved process connection (→ see page 67, feature 70 "Process connection") has to be ordered with a CSA approval (→ see page 65, feature 10 "Approval"). These devices are fitted with a separate plate bearing the registration number 0F10524.5C.

Oval flange, connection 1/4-18 NPT or RC 1/4

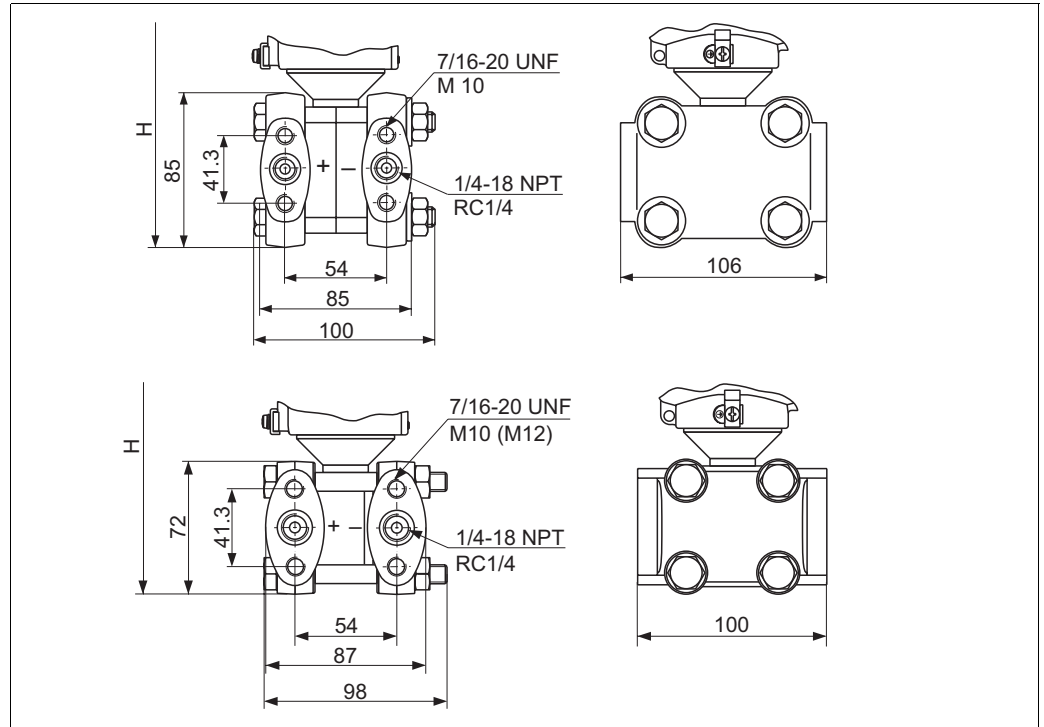

P01-PMD75xxx-00-09-xx-xx-005

Process connection PMD75,
above 10 mbar and 30 mbar measuring cell; below: Measuring cell \geq 100 mbar

H Device height → see page 37, section "Device height H"

Ver- sion	Connection	Mounting	Material	Accessories	Weight ¹
B	1/4-18 NPT IEC 61518	7/16-20 UNF	Steel C 22.8	2 vent valves (AISI 316L/1.4404) included	4.2 kg
D	1/4-18 NPT IEC 61518	7/16-20 UNF	AISI 316L ²		4.2 kg
F	1/4-18 NPT IEC 61518	7/16-20 UNF	Alloy C276 ³	Vent valves (Alloy C276/2.4819), see page 68, feature 110 "Additional options 2".	4.5 kg
U	RC 1/4	7/16-20 UNF	AISI 316L ²	2 vent valves (AISI 316L/1.4404) included	4.2kg
1	1/4-18 NPT IEC 61518	– PN 160: M10 – PN 420: M12	Steel C 22.8		4.2 kg
2	1/4-18 NPT IEC 61518	– PN 160: M10 – PN 420: M12	AISI 316L ²		4.2 kg
3	1/4-18 NPT IEC 61518	– PN 160: M10 – PN 420: M12	Alloy C276 ³	Vent valves (Alloy C276/2.4819), see page 68, feature 110 "Additional options 2".	4.5 kg

1) Weight of process connections without vent valves with 10 mbar or 30 mbar sensors, process connections without vent valves with sensors \geq 100 mbar weight approx. 800 g less. Housing weight see page 52.

2) AISI 316L/1.4435

3) Alloy C276/2.4819

Oval flange, connection 1/4-18 NPT or RC 1/4, with side vent

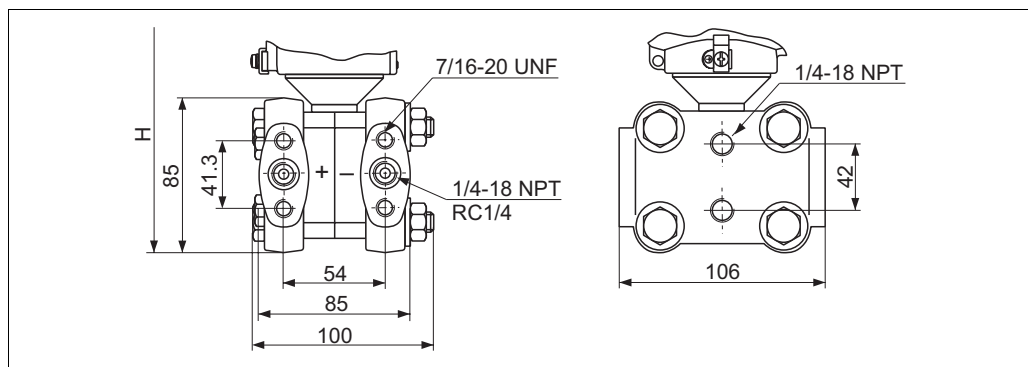

P01-PMD75xxx-06-09-xx-xx-004

Process connection PMD75, 10 mbar and 30 mbar measuring cell

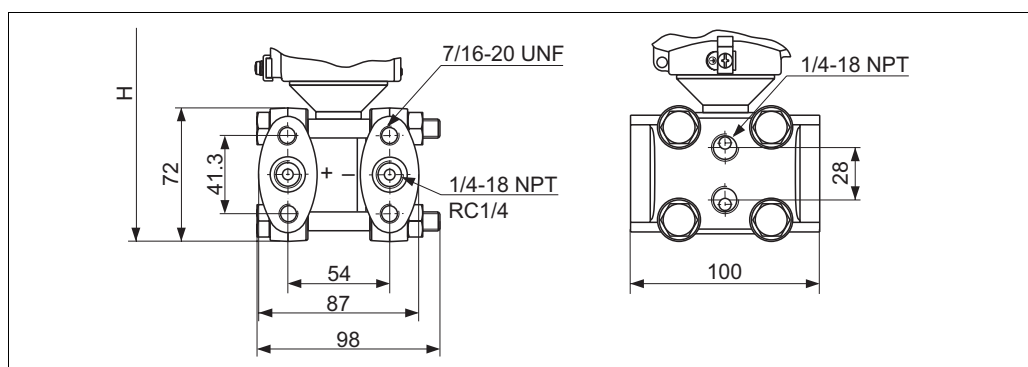

P01-PMD75xxx-06-09-xx-xx-003

Process connection PMD75, nominal value ≥ 100 mbar

H Device height → see page 37, section "Device height H"

Version	Connection	Mounting	Material	Accessories	Weight ¹
C	1/4-18 NPT IEC 61518	7/16-20 UNF	Steel C 22.8	4 locking screws (AISI 316L/1.4404) included	4.2 kg
E	1/4-18 NPT IEC 61518	7/16-20 UNF	AISI 316L ²		4.2 kg
H	1/4-18 NPT IEC 61518	7/16-20 UNF	Alloy C276 ³	Vent valves (Alloy C276/2.4819), see page 68, feature 110 "Additional options 2".	4.5 kg
V	RC 1/4	7/16-20 UNF	AISI 316L ²	4 locking screws (AISI 316L/1.4404) included	4.2 kg

- 1) Weight of process connections without vent valves with 10 mbar or 30 mbar sensors, process connections without vent valves with sensors ≥ 100 mbar weight approx. 800 g less. Housing weight see page 52
- 2) AISI 316L/1.4435
- 3) Alloy C276/2.4819

Oval flange, prepared for diaphragm seal mount

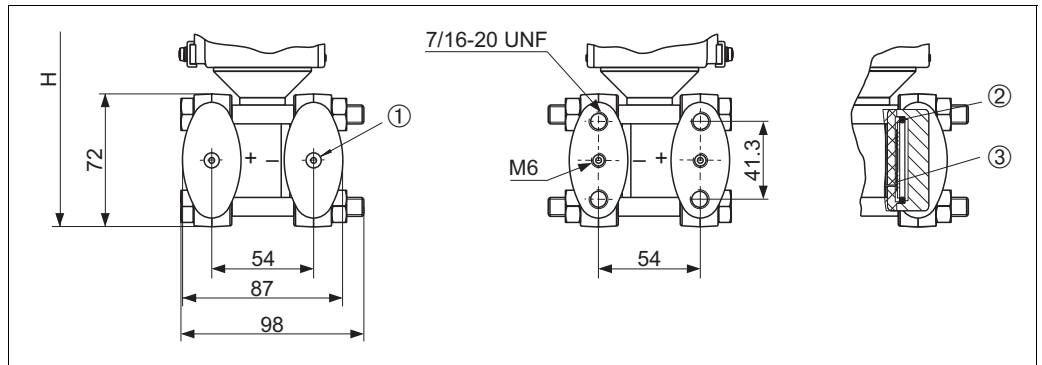

P01-PMD75xxx-06-09-xx-xx-002

Left: Process connection PMD75, version W, prepared for diaphragm seal mount

Right: Position of the copper ring seal

H Device height → see the following section "Device height H"

1 Diaphragm seal attachment

2 Copper ring seal

3 Cup diaphragm

Device height H

Description	Device height H ¹
T14 housing, optional display on the side	217 mm (230 mm)
T15 housing, optional display on the top, flat cover	223 mm (236 mm)
T15 housing, optional display on the top, high cover	234 mm (247 mm)
T17 housing, optional display on the side	233 mm (246 mm)

1) Values for devices with 10 mbar and 30 mbar measuring cell in brackets

**Process connection FMD76
(with ceramic measuring
diaphragms)**

Note!

- Some device versions have CRN approval. For a CRN-approved device, a CRN-approved process connection (→ see page 70, feature 70 "Process connection") has to be ordered with a CSA approval (→ see page 69, feature 10 "Approval"). These devices are fitted with a separate plate bearing the registration number OF10524.5C.
- FMD76 devices with an EN/DIN flange DN 80 PN 40, an ANSI flange 3" 150 lbs or a JIS flange 80 A 10 K can only be mounted with an open-ended wrench.

EN/DIN flanges, connection dimensions as per EN 1092-1/DIN 2527

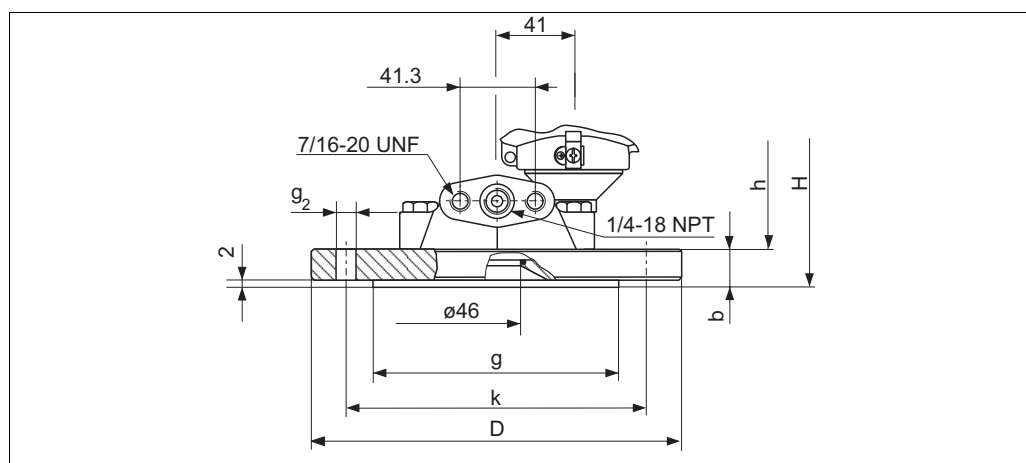

PO1-FMD76xxx-06-09-xx-xx-000

Process connection FMD76, high-pressure side: EN/DIN flange,
low-pressure side: connection 1/4-18 NPT

Application limits for version "G" in feature 70 "Process connection low-pressure side" with PVDF inlay:
PN = 10 bar, process temperature $T = -10...+60^{\circ}\text{C}$ ($14...+140^{\circ}\text{F}$)

H Device height → see page 40, section "Device height H, devices with flange"
h Height of the device without flange thickness b

Version	Flange							Boltholes			Flange weight ²
	Material	Nominal diameter	Shape ¹	Nominal pressure	Diameter D [mm]	Thickness b [mm]	Raised face g [mm]	Quantity	Diameter g ₂ [mm]	Hole circle k [mm]	
B	AISI 316L ³	DN 80	B1 (D)	PN 10-40	200	24	138	8	18	160	5,3
D	ECTFE ⁴	DN 80	–	PN 10-40	200	24	–	8	18	160	5,3
E	Alloy C276 ⁵	DN 80	B1 (D)	PN 10-40	200	24	138	8	18	160	6
F	AISI 316L ³	DN 100	B1 (C)	PN 10-16	220	22	–	8	18	180	6
G	AISI 316L ³	DN 100	B1 (D)	PN 25-40	235	26	162	8	22	190	8
H	ECTFE ⁴	DN 100	–	PN 25-40	235	26	–	8	22	190	8
J	Alloy C276 ⁵	DN 100	B1 (D)	PN 25-40	235	26	162	8	22	190	9
L	ECTFE ⁴	DN 100	–	PN 10-16	220	22	–	8	18	180	6
M	Alloy C276 ⁵	DN 100	B1 (C)	PN 10-16	220	22	–	8	18	180	6,8

1) Designation as per DIN 2527 in brackets

2) Housing weight see page 52

3) AISI 316L/1.4435

4) ECTFE coating on AISI 316L/1.4435,
When operating in hazardous area, avoid electrostatic charge of the plastic surfaces.

5) Alloy C276/2.4819

**ANSI flanges, connection dimensions as per ANSI B 16.5, raised face RF and
JIS flanges, connection dimensions as per JIS B 2220, raised face RF**

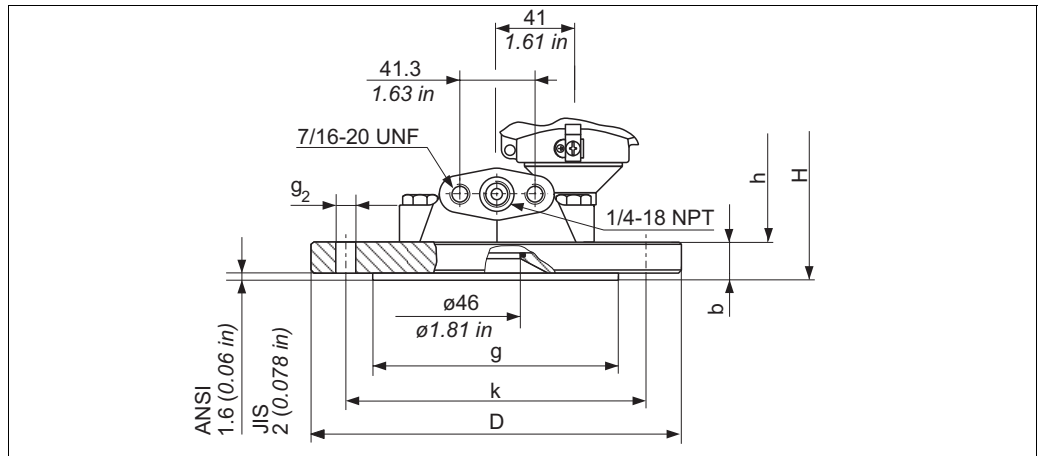

P01-FMD76xxx-06-09-xx-xx-001

Process connection FMD76, high-pressure side: ANSI or JIS flange (see table below),
low-pressure side: connection 1/4-18 NPT

H Device height → see page 40, section "Device height H, devices with flange"

h Height of the device without flange thickness *b*

Version	Flange						Boltholes			Flange weight ¹ [kg]
	Material	Nominal diameter	Class/ Nominal pressure	Diameter D [in] [mm]	Thickness b [in] [mm]	Raised face g [in] [mm]	Quantity	Diameter g ₂ [in] [mm]	Hole circle k [in] [mm]	
ANSI flanges										
P	AISI 316/ 316L ²	3 in	150 lb./sq.in	7.5 190.5	0.94 23.9	5 127	4	0.75 19.1	6 152.4	4.9
R	ECTFE ³									4.9
S	Alloy C276									5.5
T	AISI 316/ 316L ²	4 in	150 lb./sq.in	9 228.5	0.94 23.9	6.19 157.2	8	0.75 19.1	7.5 190.5	7.1
U	ECTFE ³									7.1
V	Alloy C276									8
W	AISI 316/ 316L ²	4 in	300 lb./sq.in	10 254	1.25 31.8	6.19 157.2	8	0.88 22.4	7.88 200.2	11.7
JIS flanges										
1	AISI 316L/ 1.4435	80 A	10 K	7.32 185	0.71 18	5 127	8	0.75 19.1	5.9 150	3.3
3	Alloy C276									3.7
4	AISI 316L/ 1.4435	100 A	10 K	8.27 210	0.71 18	5.95 151	8	0.75 19.1	6.89 175	4.4

1) Housing weight see page 52

2) Combination of AISI 316 for required pressure resistance and AISI 316L for required chemical resistance (dual rated)

3) ECTFE coating on AISI 316L/1.4435.

When operating in hazardous area, avoid electrostatic charge of the plastic surfaces.

Device height H, devices with flange

Description	Device height H (h + b)
T14 housing, optional display on the side	175 mm + flange thickness b (see tables)
T15 housing, optional display on the top, flat cover	181 mm + flange thickness b (see tables)
T15 housing, optional display on the top, high cover	192 mm + flange thickness b (see tables)
T17 housing, optional display on the side	191 mm + flange thickness b (see tables)

Hygienic connection, sanitary tank spud

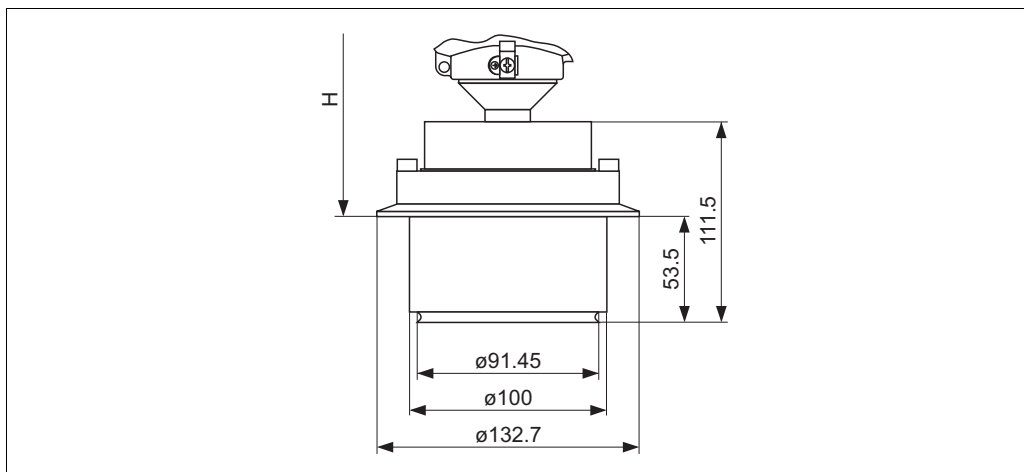

P01-FMD76xxx-06-09-xx-xx-002

Process connection FMD76, version 5, high-pressure side: sanitary tank spud, extended diaphragm seal 2", low-pressure side: connection 1/4-18 NPT, material AISI 316L/1.4435

Device height H

Description	Device height H
T14 housing, optional display on the side	257 mm
T15 housing, optional display on the top, flat cover	263 mm
T15 housing, optional display on the top, high cover	274 mm
T17 housing, optional display on the side	273 mm

Process connections FMD77 (with metallic measuring diaphragms), low-pressure side

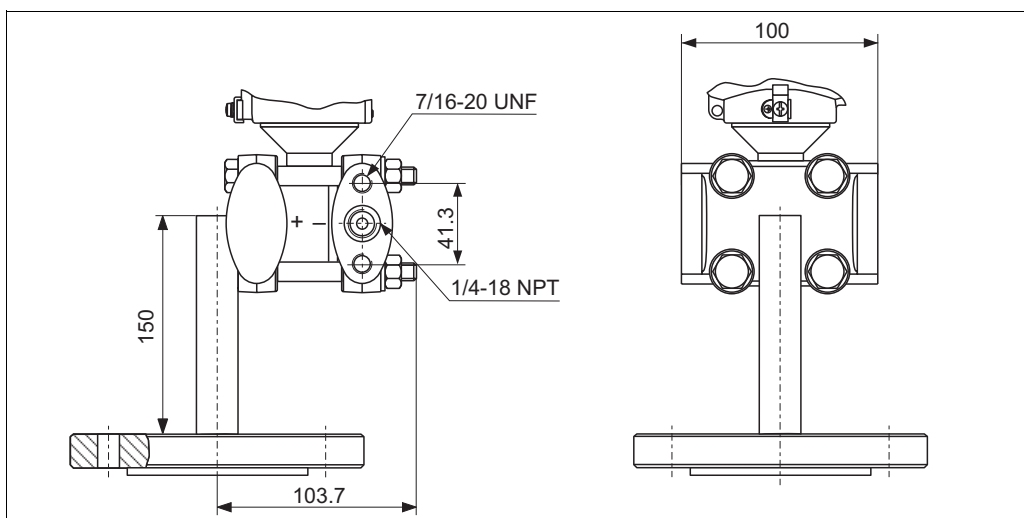

P01-FMD77xxx-06-xx-xx-xx-000

Low-pressure side: connection 1/4-18 NPT, mounting optionally 7/16-20 UNF, high-pressure side, see the following section "Process connections, high-pressure side FMD77"

**Process connections
FMD77 (with metallic
measuring diaphragms),
high-pressure side**

Note!

- Some device versions have CRN approval. For a CRN-approved device, a CRN-approved process connection (→ see page 73, feature 70 "Process connection") has to be ordered with a CSA approval (→ see page 72, feature 10 "Approval"). These devices are fitted with a separate plate bearing the registration number OF10524.5C.
- Specifications for the "T_K Ambient" and "T_K Process" are listed in the following tables. These are typical values. These temperature coefficients apply to silicone oil and the membrane material AISI 316L/1.4435. For other filling oils, this temperature coefficient must be multiplied by the T_K correction factor of the corresponding filling oil. For the T_K correction factors, see also page 55, section "Diaphragm seal filling oils".

EN/DIN flanges, connections as per EN 1092-1/DIN 2527

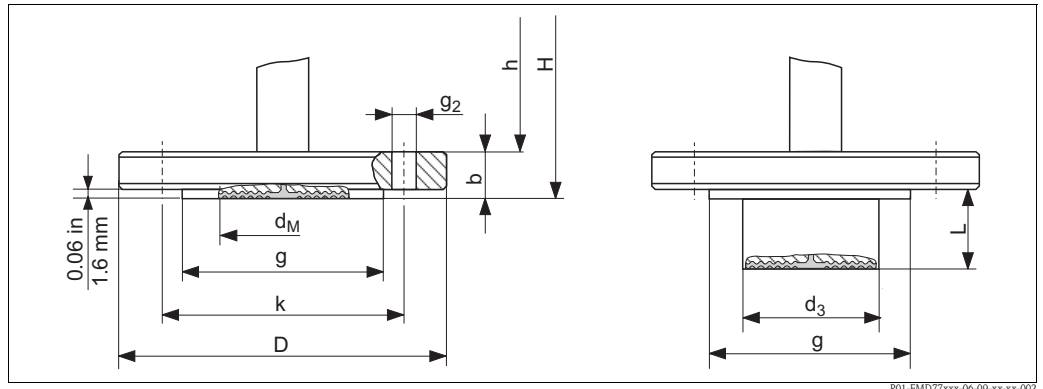

Process connection FMD77, high-pressure side EN/DIN flange with and without extended diaphragm seal, material AISI 316L/1.4435

H Device height see page 43, → section "Device height H"

h Height of the device without flange thickness b

Version	Flange								Boltholes			Diaphragm seal			Flange weight ²
	Nominal diameter	Nominal pressure	Shape ¹	Diameter D [mm]	Thick-ness b [mm]	Raised face g [mm]	Exten- sion length L [mm]	Exten- sion dia- meter d ₃	Quan- tity	Dia- meter g ₂ [mm]	Hole circle k [mm]	max. Dia- phragm dia- meter d _M [mm]	T _K Am- bient [mbar/10 K]	T _K Pro- cess [mbar/10 K]	
A	DN 50	PN 10-40	B1 (D)	165	20	102	–	–	4	18	125	59	+3.02	+1.15	3.0
B	DN 80	PN 10-40	B1 (D)	200	24	138	–	–	8	18	160	89	+0.23	+0.11	5.2
C	DN 80	PN 10-40	B1 (D)	200	24	–	50	76	8	18	160	72	+0.23	+0.11	6.2
							100								6.7
							200								7.8
F	DN 100	PN 10-16	B1 (C)	220	20	–	–	–	8	18	180	89	+0.23	+0.11	4.8
G	DN 100	PN 25-40	B1 (D)	235	24	162	–	–	8	22	190	89	+0.23	+0.11	6.7

1) Designation as per DIN 2527 in brackets

2) Housing weight see page 52

ANSI flanges, connection dimensions as per B 16.5, raised face RF

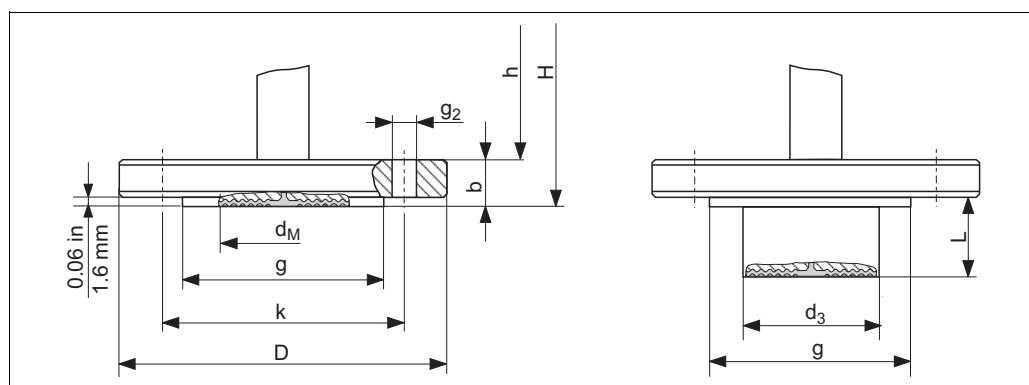

P01-FMD77xxx-06-09-zz-zz-000

Process connection FMD77, high-pressure side ANSI flange with and without extended diaphragm seal, material AISI 316/316L

H Device height → see page 43, section "Device height H "

h Height of the device without flange thickness b

Version	Flange							Boltholes			Diaphragm seal			
	Nominal diameter	Class	Diameter	Thickness	Raised face	Extension length	Extension diameter	Quantity	Diameter	Hole circle	max. Diaphragm diameter	T_K Ambient	T_K Process	Flange weight ¹
		[lb./sq.in]	D [in] [mm]	b [in] [mm]	g [in] [mm]	L [in] [mm]	d ₃ [in] [mm]		g ₂ [in] [mm]	k [in] [mm]	d _M [in] [mm]	[mbar/10 K]		[kg]
N	2	150	6 152.4	0.75 19.1	3.62 91.9	–	–	4	0.75 19.1	4.75 120.7	2.32 59	+3.02	+1.15	2.6
P	3	150	7.5 190.5	0.94 23.9	5 127	–	–	4	0.75 19.1	6 152.4	3.50 89	+0.23	+0.11	5.1
Q	3	150	7.5 190.5	0.94 23.9	5 127	2 50.8	3 76.2	4	0.75 19.1	6 152.4	2.83 72	+0.23	+0.11	6
						4 101.6								6.6
						6 152.4								7.1
						8 203.8								7.7
T	4	150	9 228.6	0.94 23.9	6.19 157.2	–	–	8	0.75 19.1	7.5 190.5	3.50 89	+0.23	+0.11	7.2
W	4	300	10 254	1.25 31.8	6.19 157.2	–	–	8	0.88 22.4	7.88 200.2	3.50 89	+0.23	+0.11	11.7

1) Housing weight see page 52

JIS flanges, connection dimensions as per JIS B 2220, raised face RF

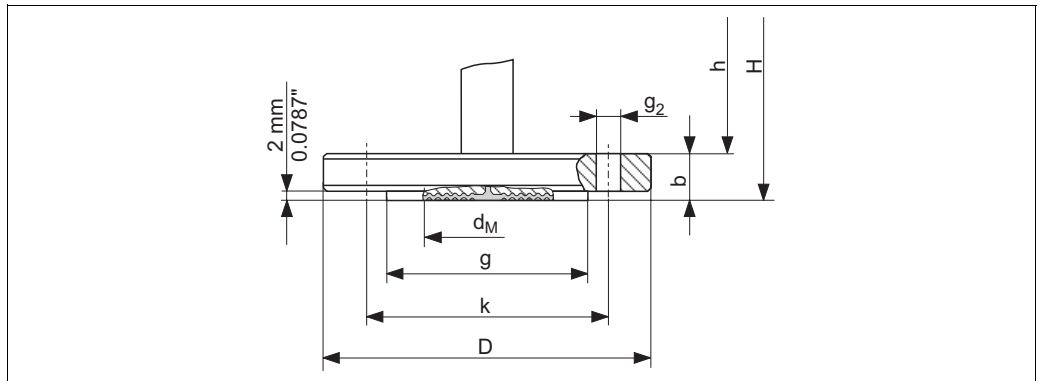

P01-FMD77xxx-06-09-xx-xx-001

Process connection FMD77, high-pressure side, JIS flange, material AISI 316L/1.4435

H Device height → see the following section "Device height H"

h Height of the device without flange thickness b

Ver- sion	Flange					Boltholes			Diaphragm seal			
	Nominal diameter	Nominal pressure	Diameter	Thick- ness	Raised face	Quan- tity	Diameter	Hole circle	max. Dia- phragm diameter	T_K Ambient	T_K Process	Flange weight ¹
			D [mm] [in]	b [mm] [in]	g [mm] [in]		g_2 [mm] [in]	k [mm] [in]	d_M [mm] [in]			
X	50 A	10 K	155 6.1	16 0.63	96 3.78	4	19 0.75	120 4.72	59 2.32	+3.02	+1.15	2.3
1	80 A	10 K	185 7.28	18 0.71	126 4.96	8	19 0.75	150 5.91	89 3.50	+0.23	+0.11	3.5
4	100 A	10 K	210 8.27	18 0.71	151 5.94	8	19 0.75	175 6.89	89 3.50	+0.23	+0.11	4.7

1) Housing weight see page 52

Device height H

Description	Device height H ($h + b$)
T14 housing, optional display on the side	325 mm + flange thickness b (see tables)
T15 housing, optional display on the top, flat cover	331 mm + flange thickness b (see tables)
T15 housing, optional display on the top, high cover	342 mm + flange thickness b (see tables)
T17 housing, optional display on the side	341 mm + flange thickness b (see tables)

FMD78 Basic unit

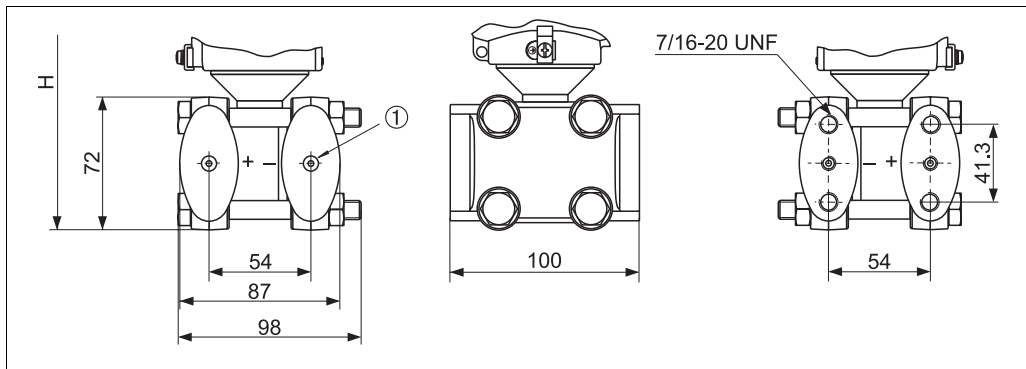

P01-FMD78.xxx-06-xx-xx-xx-000

FMD78 Basic unit

H Device height → the following section "Device height H"

1 Diaphragm seal attachment

Device height H

Description	Device height
T14 housing, optional display on the side	217 mm
T15 housing, optional display on the top, flat cover	223 mm
T15 housing, optional display on the top, high cover	234 mm
T17 housing, optional display on the side	233 mm

**Process connection FMD78
(with metallic measuring
diaphragms)**

Note!

- Specifications for the "T_K Process" are listed in the following tables. These are typically values. These temperature coefficients apply to silicone oil and the membrane material AISI 316L/1.4435. For other filling oils, this temperature coefficient must be multiplied by the T_K correction factor of the corresponding filling oil. For the T_K correction factors, see also page 55, section "Diaphragm seal filling oils".
- The temperature coefficient "T_K Ambient" is listed in relation to the capillary length on page 56 in the "Influence of the temperature on the zero point" section.
- The weights of the diaphragm seals are given in the tables. See page 35 for the weight of the transmitter and page 52 for the weight of the housing.
- The following drawings are drawings that illustrate how the system works in principle. In other words, the dimensions of a diaphragm seal supplied can deviate from the dimensions given in this document.

Diaphragm seal cell structure

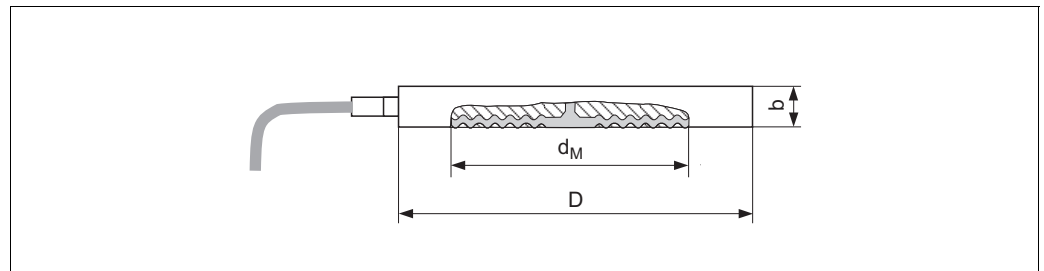

F01-FMD78xxxx-06-09-xx-xx-000

Process connection FMD78, material AISI 316L

Version	Flange				Diaphragm seal			
	Nominal diameter	Nominal pressure ¹	Diameter D [mm]	Thickness b [mm]	max. Diaphragm diameter d _M [mm]	T _K Process [mbar/10K]	Minimum installation distance A [mm]	Weight of two diaphragm seals [kg]
UF	DN 50	PN 16-400	102	20	59	+1.21	130	2.6
UH	DN 80	PN 16-400	136	20	89	+0.19	130	4.6
UJ	DN 100	PN 16-400	158	20	89	+0.19	130	6.2

Version	Flange				Diaphragm seal			
	Nominal diameter [in]	Nominal pressure ¹ [lb/sq.in]	Diameter D [in] [mm]	Thickness b [in] [mm]	max. Diaphragm diameter d _M [in] [mm]	T _K Process [mbar/10K]	Minimum installation distance [in] [mm]	Weight of two diaphragm seals [kg]
VF	2	150-2500	3.99 99	0.79 20	2.32 59	+1.21	5 130	2.6
VH	3	150-2500	5.00 127	0.79 20	3.50 89	+0.08	5 130	4.6
VJ	4	150-2500	6.22 158	0.79 20	3.50 89	+0.19	5 130	6.2

1) The specified nominal pressure applies to the diaphragm seal. The maximum pressure for the measuring device is dependent on the lowest-rated element, with regard to pressure, of the selected components. → See also page 31, section "Pressure specifications".

Threaded connection ISO 228 G 1/2 B and ANSI 1/2 MNPT, separator with PTFE seal

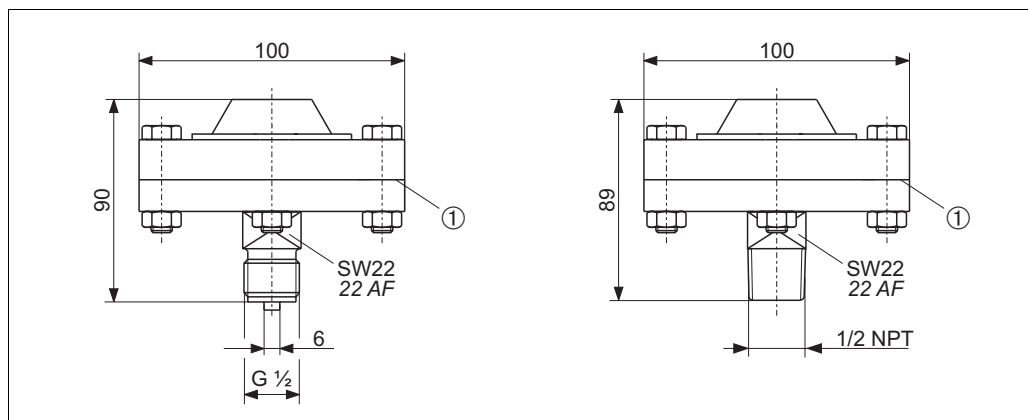

P01-FMD78xxx-06-09-xx-xx-012

Process connection FMD78, left: with threaded connection ISO 228 G 1/2 B, right: with threaded connection ANSI 1/2 MNPT

1 PTFE seal as standard

Version	Material	Nominal pressure	T _K Process [mbar/10 K]	Weight of two diaphragm seals [kg]
GA	AISI 316L	PN 40	+0.1	2.9
RL	AISI 316L	PN 40	+0.1	2.9

Tri-Clamp ISO 2852

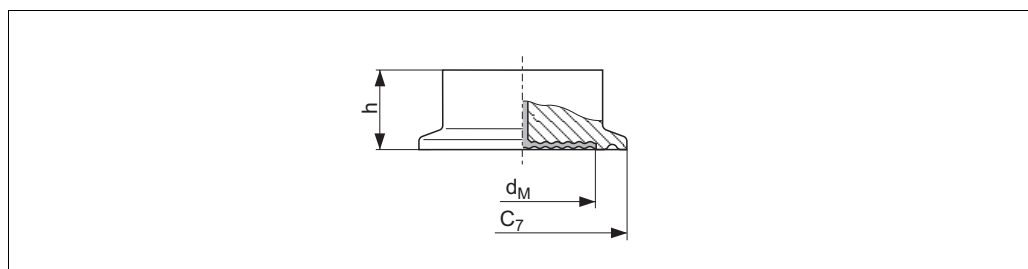

P01-FMD78xxx-06-09-xx-xx-005

Process connection FMD78, Material: AISI 316L/1.4435, surface roughness of the wetted surfaces ≤ 0.8 μm as standard. Lower surface roughness on request.

Version	Nominal diameter ISO 2852	Nominal diameter DIN 32676	Nominal diameter [in]	Diameter C ₇ [mm]	max. Diaphragm diameter d _M [mm]	Height h [mm]	T _K Process [mbar/10 K]	Weight of two diaphragm seals [kg]
TB	DN 25	DN 25	1	50.5	24	37	+10.45	0.64
TC	DN 38	DN 40	1 1/2	50.5	36	30	+5.44	2.0
TD	DN 51	DN 50	2	64	48	30	+1.91	2.2
TF	DN 76.1	–	3	91	73	30	+0.08	2.4

Tri-Clamp pipe diaphragm seal ISO 2852

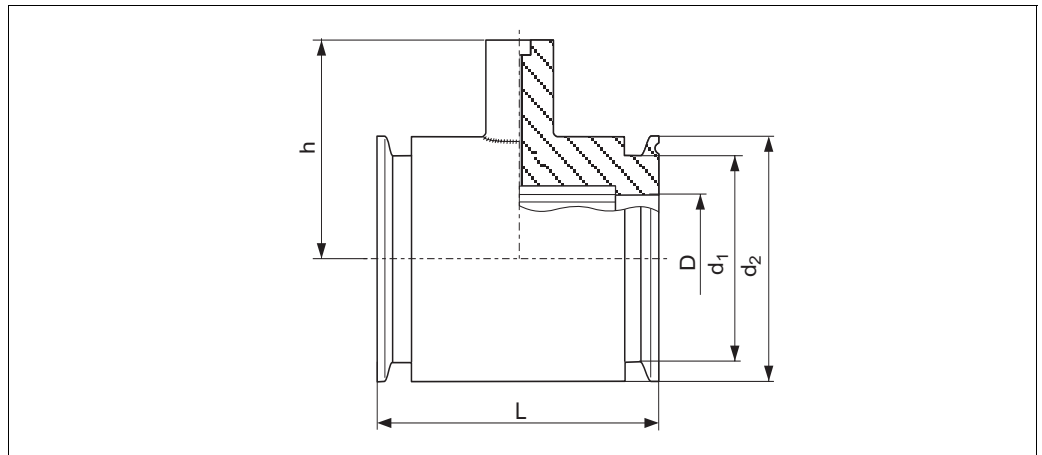

P01-FMD78xxx-00-09-xx-xx-001

Process connection FMD78, Material: AISI 316L, surface roughness of the wetted surfaces $\leq 0.8 \mu\text{m}$ as standard. Lower surface roughness on request.

Version	Nominal diameter ISO 2852	Nominal diameter	Diameter	Diameter	Diameter	Height	Face-to-face length	T _K Process	Weight of two diaphragm seals
		[in]	D [mm]	d ₁ [mm]	d ₂ [mm]	h [mm]	L [mm]	[mbar/10 K]	[kg]
SB	DN 25	1	22.5	43.5	50.5	67	126	+5.10	3.4
SC ¹⁾	DN 38	1 1/2	35.5	43.5	50.5	67	126	+2.51	2
SD ¹⁾	DN 51	2	48.6	56.5	64	79	100	+2.51	3.4

1) Including 3.1 and pressure test as per Pressure Equipment Directive, category II

Varivent N for pipes DN 40 – DN 162

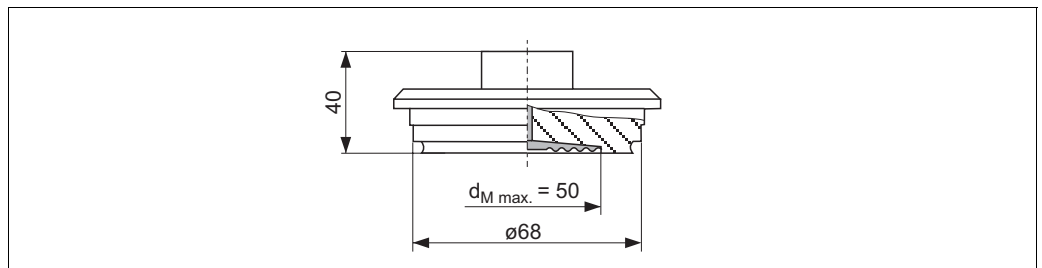

P01-FMD78xxx-00-09-xx-xx-006

Process connection FMD78, surface roughness of the wetted surfaces $\leq 0.8 \mu\text{m}$ as standard. Lower surface roughness on request.

Version	Material	Nominal pressure	T _K Process	Weight of two diaphragm seals
			[mbar/10 K]	[kg]
TR	AISI 316L/1.4435	PN 40	+2.01	2.6

DRD 65 mm

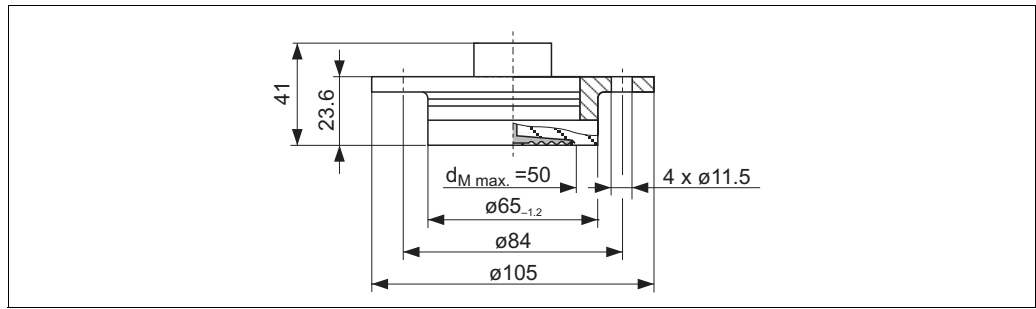

Process connection FMD78, surface roughness of the wetted surfaces $\leq 0.8 \mu\text{m}$ as standard. Lower surface roughness on request.

Version	Material	Nominal pressure	T _K Process [mbar/10 K]	Weight of two diaphragm seals [kg]
TK	AISI 316L/1.4435	PN 25	+2.01	1.5

Hygienic connection, sanitary tank spud, extended diaphragm seal 2"

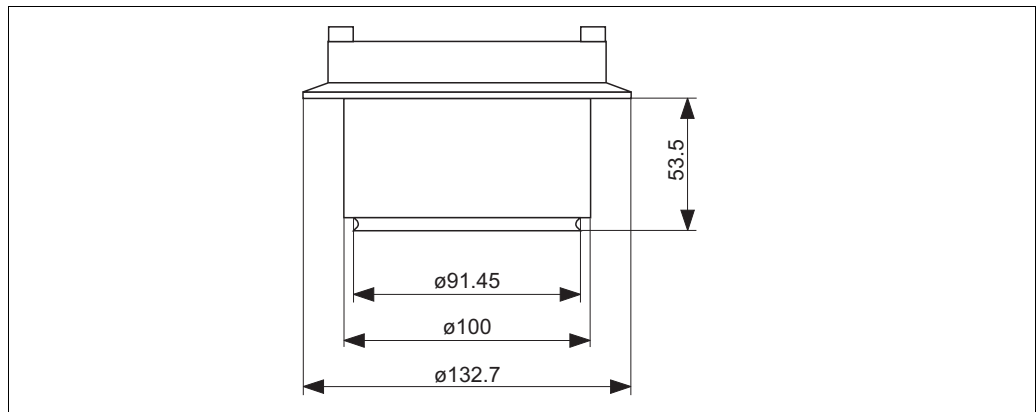

Process connection FMD78, surface roughness of the wetted surfaces $\leq 0.8 \mu\text{m}$ as standard. Lower surface roughness on request.

Version	Material	T _K Process [mbar/10 K]	Weight of two diaphragm seals [kg]
WH	AISI 316L	+1.64	5

Taper adapter with coupling nut, DIN 11851 (dairy fitting)

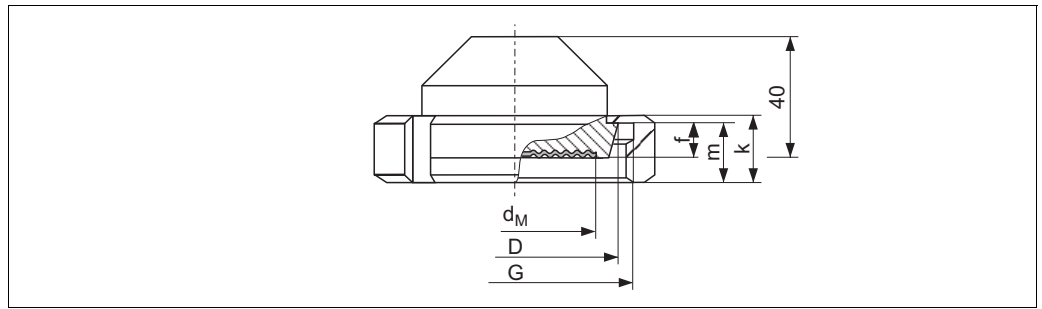

P01-FMD78xxx-06-09-xx-xx-007

Process connection FMD78, material AISI 316L/1.4435, surface roughness of the wetted surfaces $\leq 0.8 \mu\text{m}$ as standard. Lower surface roughness on request.

Version	Taper adapter				Slotted nut			Diaphragm seal		
	Nominal diameter	Nominal pressure	Diameter	Adapter height	Thread	Height	Height	max. Diaphragm diameter	T_K Process	Weight of two diaphragm seals
			D	f		G	k			
[mm]	[mm]	[mm]	[mm]	[mm]	[mm]	[mm]	[mm]	[mm]	[mbar/10 K]	[kg]
MR	DN 50	PN 25	68.5	11	Rd 78 x 1/6"	22	19	52	+1.21	2.2
MS	DN 65	PN 25	86	12	Rd 95 x 1/6"	25	21	66	+0.29	4.0
MT	DN 80	PN 25	100	12	Rd 110 x 1/4"	30	26	81	+0.19	5.1

Threaded adapter, DIN 11851 (dairy fitting)

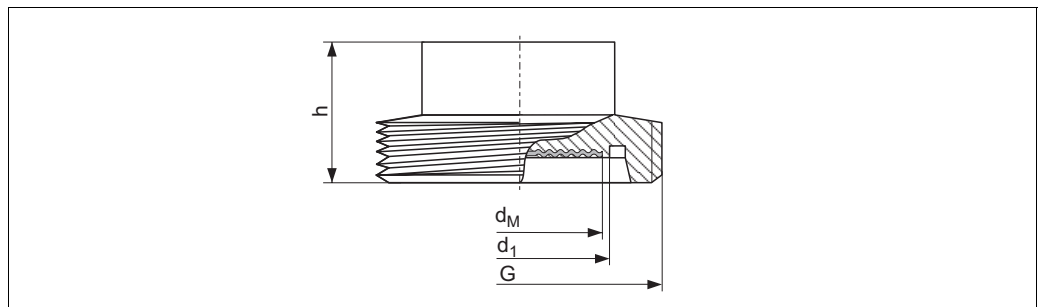

P01-FMD78xxx-06-09-xx-xx-006

Process connection FMD78, material AISI 316L/1.4435, surface roughness of the wetted surfaces $\leq 0.8 \mu\text{m}$ as standard. Lower surface roughness on request.

Version	Threaded adapter					Diaphragm seal		
	Nominal diameter	Nominal pressure	Diameter	Height	Thread	max. Diaphragm diameter	T_K Process	Weight of two diaphragm seals
			d_1	h				
[mm]	[mm]	[mm]	[mm]	[mm]	[mm]	[mm]	[mbar/10 K]	[kg]
M3	DN 50	PN 25	54	35	Rd 78 x 1/6"	52	+1.21	1.8
M4	DN 65	PN 25	71	40	Rd 95 x 1/6"	66	+0.29	3.4
M5	DN 80	PN 25	85	40	Rd 110 x 1/4"	81	+0.19	4.0

EN/DIN flanges, connection dimensions as per EN 1092-1/DIN 2527
 JIS flanges, connection dimensions as per JIS B 2220

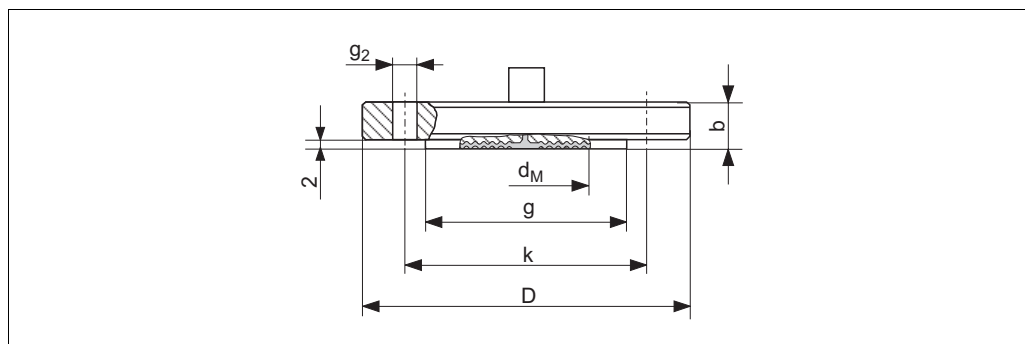

P01-FMD78xxx-06-09-xx-xx-009

Process connection FMD78, EN/DIN flange, Material AISI 316L

Ver- sion	EN/DIN flange						Boltholes			Diaphragm seal		
	Nominal diameter	Nominal pressure	Shape ¹	Dia- meter	Thick- ness	Raised face	Quan- tity	Dia- meter	Hole circle	max. Diaphragm diameter	T _K Process	Weight of two diaphragm seals
				D [mm]	b [mm]	g [mm]	g ₂ [mm]	k [mm]	d _M [mm]	[mbar/10 K]	[kg]	
B3	DN 50	PN 10-40	B1 (D)	165	20	102	4	18	125	59	+1.21	6.0
B5	DN 80	PN 10-40	B1 (D)	200	24	138	8	18	160	89	+0.19	10.5
BT	DN 100	PN 10-16	B1 (C)	220	20	–	8	18	180	89	+0.19	9.5
B6	DN 100	PN 25-40	B1 (D)	235	24	162	8	22	190	89	+0.19	13.3

1) Designation as per DIN 2527 in brackets

Ver- sion	JIS flange					Boltholes			Diaphragm seal		
	Nominal diameter	Nominal pressure	Diameter	Thickness	Raised face	Quantity	Diameter	Hole circle	max. Diaphragm diameter	T _K Process	Weight of two diaphragm seals
			D [mm]	b [mm]	g [mm]	g ₂ [mm]	k [mm]	d _M [mm]	[mbar/10 K]	[kg]	
KF	50 A	10 K	155	16	96	4	19	120	59	+1.21	4.6
KL	80 A	10 K	185	18	127	8	19	150	89	+0.19	7.0
KH	100 A	10 K	210	18	151	8	19	175	89	+0.19	9.4

ANSI flanges, connection dimensions as per ANSI B 16.5, raised face RF

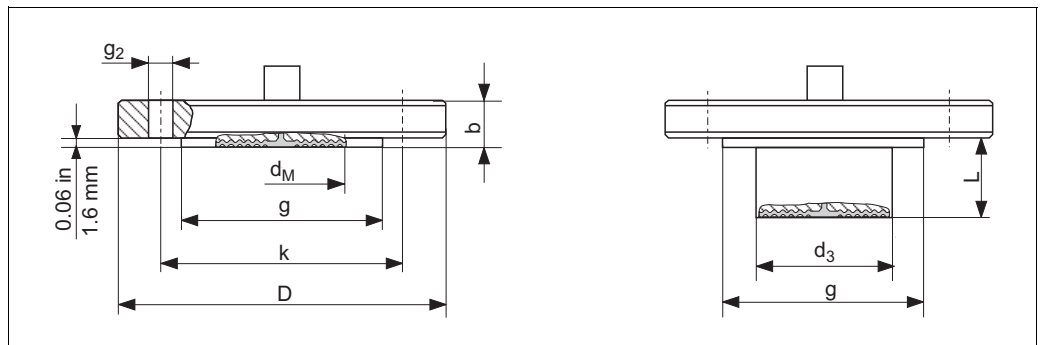

P01-FMD78xxx-06-09-xx-xx-010

Process connection FMD78, ANSI flange with and without extended diaphragm seal, material AISI 316/AISI 316L

Ver- sion	Flange							Boltholes			Diaphragm seal			
	Nominal dia- meter	Class	Dia- meter	Thick- ness	Raised face	Exten- sion length	Exten- sion dia- meter	Quan- tity	Dia- meter	Hole circle	max. Dia- phragm diameter	T _K Process	Weight of two dia- phragm seals	
		[lb/sq.in]	D [in] [mm]	b [in] [mm]	g [in] [mm]	L [in] [mm]	d ₃ [in] [mm]		g ₂ [in] [mm]	k [in] [mm]	d _M [in] [mm]	[mbar/ 10 K]	[kg]	
AF	2	150	6 152.4	0.75 19.1	3.62 91.9	–	–	4	0.75 19.1	4.75 120.7	2.32 59	+1.21	5.2	
AR	2	300	6.5 165.1	0.88 22.5	3.62 91.9	–	–	8	0.75 19.1	5 127	2.32 59	+1.21	6.8	
AG	3	150	7.5 190.5	0.94 23.9	5 127	–	–	4	0.75 19.1	6 152.4	3.50 89	+0.19	10.2	
AS	3	300	8.25 209.5	1.12 28.4	5 127	–	–	8	0.88 22.4	6.62 168.1	3.50 89	+0.19	14	
J4	3	150	7.5 190.5	0.94 23.9	5 127	2	3	4	0.75 19.1	6 152.4	2.83 72	+0.29	12	
						4	76							13.2
						6								14.2
						8								15.4
AH	4	150	9 228.6	0.94 23.9	6.19 157.2	–	–	8	0.75 19.1	7.5 190.5	3.50 89	+0.19	14.4	
AT	4	300	10 254	1.25 31.8	6.19 157.2	–	–	8	0.88 22.4	7.88 200.1	3.50 89	+0.19	23.4	
J5	4	150	9 228.6	0.94 23.9	6.19 157.2	2	3.7	8	0.75 19.1	7.5 190.5	3.50 89	+0.19	17.3	
						4	94							19.8
						6								22.3
						8								24.8

Weight**Housing**

	T14		T15	T17
	Aluminium	AISI 316L/1.4435	Aluminium	AISI 316L/1.4404
with electronic insert and display	1.2 kg	2.1 kg	1.8 kg	1.2 kg
with electronic insert without display	1.1 kg	2.0 kg	1.7 kg	1.1 kg

Process connections

→ See corresponding process connection, page 32 ff.

Material**T14/T15 housing:**

- T14 housing, selectable:
 - Die-cast aluminium with protective powder-coating on polyester basis: RAL 5012 (blue), cover: RAL 7035 (grey)
 - Precision cast stainless steel AISI 316L (1.4435)
- T15 housing: Die-cast aluminium with protective powder-coating on polyester basis: RAL 5012 (blue), cover: RAL 7035 (grey)
- External operation (keys and key covering): Polycarbonate PC-FR Lexan UL 940 UL94VO, RAL 7035 (grey)
- Sight glass:
 - Aluminium housing: Polycarbonat (PC), for Dust-Ex, EEx d, FM XP and CSA XP: Mineral glass
 - Stainless steel housing: Mineral glass
- Cable gland: Polyamid (PA)
- Bind plug: PBT-GF30 FR, for Dust Ex, EEx d, FM XP and CSA XP: AISI 316L (1.4435)
- Seal for cable gland and plug: Silicone (VMQ)
- O-ring for cover sealing: EPDM
- Nameplates: AISI 304 (1.4301)

T17 housing:

- Housing: Stainless steel AISI 316L (1.4404)
- Sight glass: Polycarbonat (PC) or mineral glass
- Cable gland: Polyamid (PA), for Dust-Ex: CuZn nickel-plated
- Bind plug: PBT-GF30 FR, for Dust-Ex: AISI 316L (1.4435)
- Seal for cable gland and plug: Silicone (VMQ)
- Pressure compensation filter: PA6 GF10, O-Ring: Silicone (VMQ)
- O-ring for cover sealing: Silicone (VMQ)
- Nameplates: lasered

Miscellaneous:

- Measuring cell PMD70/FMD76, filling cell
 - 25 mbar and 100 mbar measuring cell: Silicone oil
 - 500 mbar and 3000 mbar measuring cell: Mineral oil
 - for oxygen and ultra pure gas applications: Inert oil (Voltalef 1A)
- Membrane material:
 - PMD70/FMD76: Al₂O₃ (Aluminium-oxide-ceramic)
 - PMD75, FMD77, FMD78:
 - AISI 316L (1.4435)
 - Alloy C276 (2.4819)
 - Monel 400 (2.4360)
 - Tantal
 - AISI 316L (1.4435) with Gold-Rhodium coating (FMD77/FMD78 only)
 - AISI 316L (1.4435) with 0.09 mm PTFE foil (FMD77/FMD78 only)
- Process diaphragm PMD70/FMD76: Al₂O₃ (Aluminium-oxide-ceramic)
- Mounting accessories: Mounting kit with screws AISI 304 (1.4301)
- Capillary: AISI 316 Ti (1.4571)
- Protective hose for capillary: AISI 304 (1.4301)
- External earth terminal: AISI 304 (1.4301)
- Screws and nuts for side flanges:
 - PMD70: hex.-headed bolt DIN 931-M10x50-A2-70, hex.-headed nut: DIN 934-M10-A4-70
 - PMD75 PN 160: hex.-headed bolt ISO 4014-M12x90-A4
 - PMD75 PN 420: hex.-headed nut ISO 4032-M12-A4-bs

→ For process connections, seals and filling oils see ordering information, page 53 ff.

Planning instructions, diaphragm seal systems

Applications

Diaphragm seal systems should be used if the process media and the device should be separated. Diaphragm seal systems offer clear advantages in the following instances:

- In the case of high process temperatures (→ See also page 30, section "Process temperature limits".)
- In the case of process media that crystallise
- In the case of corrosive or highly various process media or process media with solids content
- In the case of heterogeneous and fibrous process media
- If good and rapid measuring point cleaning is necessary
- If the measuring point is exposed to vibrations
- For mounting locations that are difficult to access

Design and operation mode

Diaphragm seals are separating equipment between the measuring system and the process medium.

A diaphragm seal system consists of:

- A diaphragm seal in a one-sided system, e.g. FMD77 or two diaphragm seals, in a two-sided system, e.g. FMD78
- One capillary tube or two capillary tubes
- Fill fluid and
- A differential pressure transmitter.

The process pressure acts via the diaphragm seal membrane on the liquid-filled system, which transfers the process pressure via the capillary tube onto the sensor of the differential pressure transmitter.

Endress+Hauser delivers all diaphragm seal systems as welded versions. The system is hermetically sealed, which ensures the highest reliability.

Note!

The correlations between the individual diaphragm seal components are presented in the following section. For further information and comprehensive diaphragm seal system designs, please contact your local Endress+Hauser Sales Center.

Diaphragm seal

The diaphragm seal determines the application range of the system by

- the diaphragm diameter
- the diaphragms: stiffness and material
- the design (oil volume).

Diaphragm diameter

The larger the diaphragm diameter (less stiffness), the smaller the temperature effect on the measurement result.

Note: To keep the temperature effect in practice-oriented limits, you should select diaphragm seals with a nominal diameter of \geq DN 80, in as far as the process connection allows for it.

Diaphragm stiffness

The stiffness is dependent on the diaphragm diameter, the material, any available coating and on the diaphragm thickness and shape. The diaphragm thickness and the shape are defined constructively. The stiffness of a diaphragm seal membrane influences the temperature operating range and the measuring error caused by temperature effects.

Capillary

Diaphragm seals are used with the following capillary internal diameters as standard:

- \leq DN 50: 1 mm
- $>$ DN 50: 2 mm

The capillary tube influences the T_K zero point, the ambient temperature operating range and the response time of a diaphragm seal system as a result of its length and internal diameter.

→ See also page 56 ff, sections "Influence of the temperature on the zero point", "Ambient temperature range" and "Response time".

→ Observe the installation instructions regarding capillary tubes. See page 61 ff, section "Installation instructions".

Filling oil

When selecting the filling oil, fluid and ambient temperature as well as the operating pressure are of crucial importance. Observe the temperatures and pressures during commissioning and cleaning. A further selection criterion is the compatibility of the filling oil with the requirements of the process medium. For this reason, only filling oils that are harmless to health are used in the food industry, such as vegetable oil or silicone oil. → See also the following section "Diaphragm seal filling oils".

The filling oil used influences the T_K zero point and the temperature operating range of a diaphragm seal system and the response time. → See also page 56 ff, sections "Influence of the temperature on the zero point" and "Response time".

Differential pressure transmitter

The differential pressure transmitter influences the temperature operating range, the T_K zero point and the response time as a result of the volume of its side flange and as a result of its volume change. The volume change is the volume that has to be shifted to pass through the complete measuring range.

Differential pressure transmitters from Endress+Hauser are optimised with regard to minimum volume change and side flange.

Diaphragm seal filling oils

Version ¹	Filling oil	Permissible temperature range at $0.05 \text{ bar} \leq p_{\text{abs}} \leq 1 \text{ bar}$	Permissible temperature range at $p_{\text{abs}} \geq 1 \text{ bar}$	Density [g/cm ³]	Viscosity [cSt at 25°C (77°F)]	Coefficient of thermal expansion [1/K]	T_K correction factor	Notes
FMD77: A FMD78: A, 1	Silicone oil	-40...+180°C (-40...+356°F)	-40...+250°C (-40...+482°F)	0.96	100	0.00096	1	suitable for foods
FMD77: V FMD78: C, 3	High-temperature oil	-10...+200°C (+14...+392°F)	-10...+350°C (+14...+662°F)	1.07	37	0.0007	0.72	high temperatures
FMD77: F FMD78: D, 4	Inert oil	-40...+80°C (-40...+176°F)	-40...+175°C (-40...+347°F)	1.87	27	0.000876	0.91	Oil for ultra pure gas and oxygen applications
FMD77: D FMD78: B, 2	Vegetable oil	-10...+120°C (+14...+248°F)	-10...+200°C (+14...+392°F)	0.94	9.5	0.00101	1.05	suitable for foods FDA 21 CFR 172.856
FMD77: L FMD78: E, 5	Low temperature oil	-90...+80°C ² (-130...176°F)	-90...+180°C ² (-130...+356°F)	0.92	4.4	-	-	low temperatures

- 1) Version for feature 90 in the order code
- 2) Observe temperature limits of the device (→ page 29 and page 30)

Influence of the temperature on the zero point

A temperature change results in a volume change of the filling oil. The volume change is dependent on the coefficient of thermal expansion of the filling oil and on the volume of the filling oil at calibration temperature (constant in the range: +21 to +33°C (+69.8 to 91.4°F)). → See also page 46, section "Diaphragm seal filling oils".

For example, the filling oil expands in the event of a temperature increase. The additional volume presses against the diaphragm seal membrane. The stiffer a diaphragm is, the greater its return force, which counteracts a volume change and acts on the measuring cell together with the operating pressure, thus shifting the zero point. For the "T_K Process", see page 45 ff, section "Process connections FMD78".

The following diagrams display the temperature coefficient "T_K Ambient" dependent on the capillary length. The following application is displayed: capillary temperature and transmitter temperature (ambient temperature) change, the process temperature corresponds to the calibration temperature.

The temperature coefficients obtained from the diagrams apply to silicone oil and the membrane material AISI 316L/1.4435. For other filling oils, these temperature coefficients must be multiplied by the T_K correction factor of the corresponding filling oil. For the T_K correction factors, see page 55, section "Diaphragm seal filling oils".

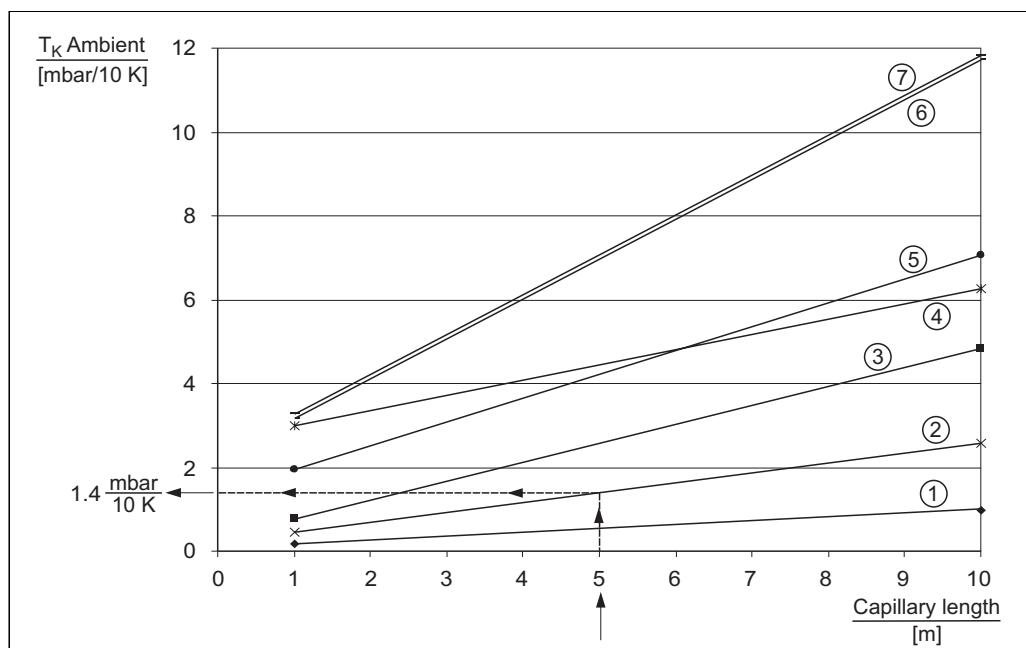

P01-FMD78:xxx-05-xx-xx-xx-004

Example for:

- Diaphragm seal versions "B5, EN/DIN Flange DN 80 PN 10-40 B1, AISI 316L"
- Capillary length: 5 m
- Ambient temperature, capillary/transmitter: 45°C
- Filling oil: silicone oil

1. Select characteristic curve type for the diaphragm seal versions "B5" in accordance with the following table.
Result: characteristic curve type 2
2. Obtain value for T_K Ambient from the diagram.
Result: 1.4 mbar/10 K
3. $T_{\text{Ambient}} - T_{\text{Calibration}} = 45^\circ\text{C} - 25^\circ\text{C} = 20^\circ\text{C} \Rightarrow 1.4 \text{ mbar}/10 \text{ K} \times 20 \text{ K} = 2.8 \text{ mbar}$

Result: In this application, the zero point is shifted by 2.8 mbar.

Note!

- The influence of temperature on the zero point can be corrected with position calibration.
- The temperature influence can be minimised by using a filling oil with a smaller coefficient of thermal expansion, shorter capillaries, diaphragm seals with larger diaphragm diameter or by using a smaller capillary internal diameter.

Characteristic type	Version	Diaphragm seal
1	TF	Tri-Clamp, ISO 2852 DN 76.1 (3"), AISI 316L/1.4435
2	GA	Thread ISO 228 G 1/2 B, PN 40, AISI 316L, Separator, PTFE seal
	RL	Thread ANSI 1/2 FNPT, PN 40, AISI 316L, Separator, PTFE seal
	UH	Cell DN 80 PN 16-400, AISI 316L
	UJ	Cell DN 100 PN 16-400, AISI 316L
	VH	Cell 3" 150-2500 lbs, AISI 316L
	VJ	Cell 4" 150-2500 lbs, AISI 316L
	B5	EN/DIN flange DN 80 PN 10-40 B1, AISI 316L
	BT	EN/DIN flange DN 100 PN 10-16 B1, AISI 316L
	B6	EN/DIN flange DN 100 PN 25-40 B1, AISI 316L
	AG	ANSI flange 3" 150 lbs RF, AISI 316/316L
	AS	ANSI flange 3" 300 lbs RF, AISI 316/316L
	AH	ANSI flange 4" 150 lbs RF, AISI 316/316L
	J5	ANSI flange 4" 150 lbs RF, AISI 316/316L, Extensions: 2"/4"/6"/8"
	AT	ANSI flange 4" 300 lbs RF, AISI 316/316L
	KL	JIS flange 80 A 10 K RF, AISI 316L
	KH	JIS flange 100 A 10 K RF, AISI 316L
	MT	DIN 11851 DN 80 PN 25, AISI 316L/1.4435
	M5	DIN 11851 DN 80 PN 25 socket, AISI 316L/1.4435
3	MS	DIN 11851 DN 65 PN 25, AISI 316L/1.4435
	M4	DIN 11851 DN 65 PN 25 socket, AISI 316L/1.4435
	J4	ANSI flange 3" 150 lbs RF, AISI 316/316L, Extensions: 2"/4"/6"/8"
4	SC	Pipe seal diaphragm Tri Clamp, ISO 2852 DN 38 (1 1/2"), AISI 316L/1.4435
	SD	Pipe seal diaphragm Tri Clamp, ISO 2852 DN 51 (2"), AISI 316L/1.4435
5	UF	Cell DN 50 PN 16-400, AISI 316L
	VF	Cell 2" 150-2500 lbs, AISI 316L
	B3	EN/DIN flange DN 50 PN 10-40 B1, AISI 316L
	AF	ANSI flange 2" 150 lbs RF, AISI 316/316L
	AR	ANSI flange 2" 300 lbs RF, AISI 316/316L
	KF	JIS flange 50 A 10 K RF, AISI 316L
	MR	DIN 11851 DN 50 PN 25, AISI 316L/1.4435
	M3	DIN 11851 DN 50 PN 25 socket, AISI 316L/1.4435
6	TD	Tri-Clamp, ISO 2852 DN 51 (2"), DIN 32676 DN 50, AISI 316L/1.4435
7	TK	DRD 65 mm, PN 25, AISI 316L/1.4435
	TR	Varivent Type N for tubes DN 40 – DN 162, PN 40, AISI 316L/1.4435

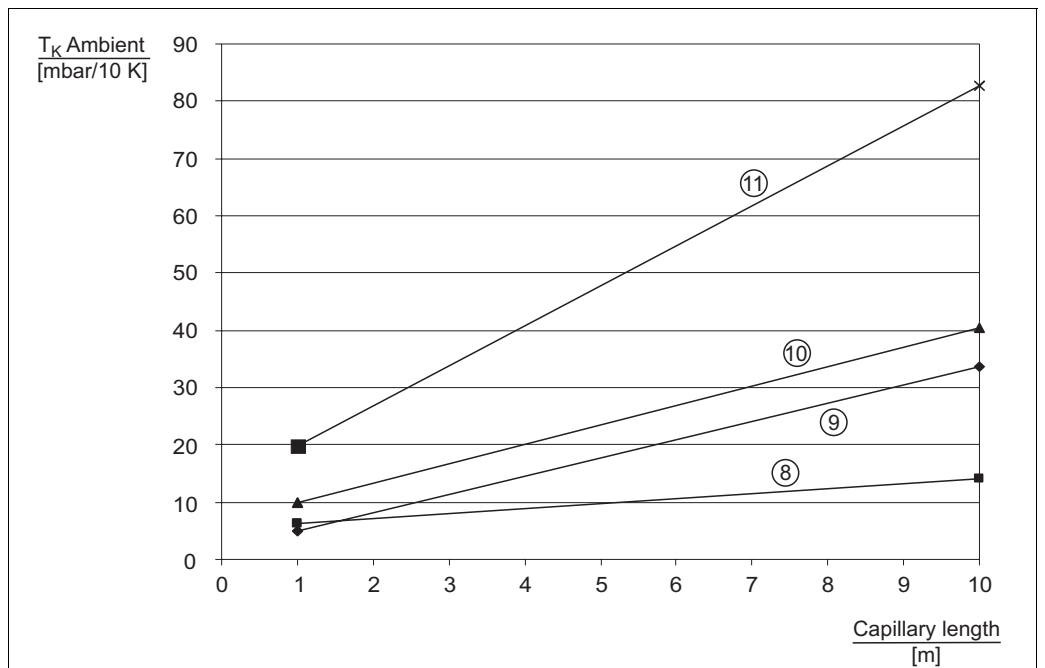

P01-FMD78xxx-05-xx-xx-xx-005

Characteristic type	Version	Diaphragm seal
8	SB	Pipe seal diaphragm Tri-Clamp, ISO 2852 DN 25 (1"), AISI 316L/1.4435
9	WH	Sanitary tank spud, AISI 316L/1.4435, Extensions 2"
10	TC	Tri-Clamp, ISO 2852 DN 38 (1 – 1 1/2"), DIN 32676 DN 40, AISI 316L/1.4435
11	TB	Tri-Clamp, ISO 2852 DN 25 (1"). DIN 32676 DN 25, AISI 316L/1.4435

Ambient temperature range

The filling oil, capillary length, capillary internal diameter, process temperature and the oil volume of the diaphragm seal determine the ambient temperature operating range of the diaphragm seal system. The following diagrams display the permitted ambient temperature operating range in relation to the capillary length. The diagrams apply to a process temperature of +25°C (+77°F) and to silicone oil. The operating range can be extended by using a filling oil with a smaller coefficient of expansion and by using shorter capillaries.

Note!

- Endress+Hauser recommends using low temperature oil for applications that require short response times or that are near the lower temperature limit. → See also page 55, "Diaphragm seal filling oils" section.
- For further information, comprehensive diaphragm seal system designs and measuring technology solutions acting close to the operating limits, please contact your local Endress+Hauser Sales Center.

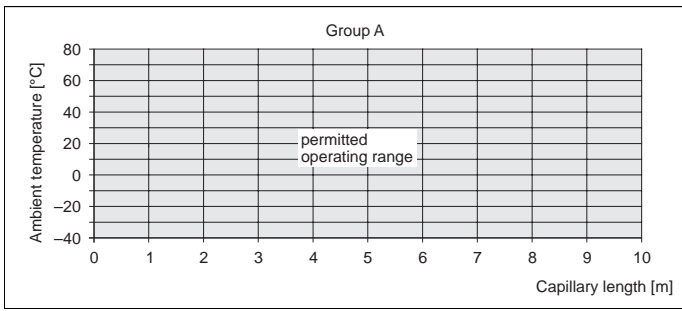

P01-FMD78xxx-05-xx-xx-xx-006

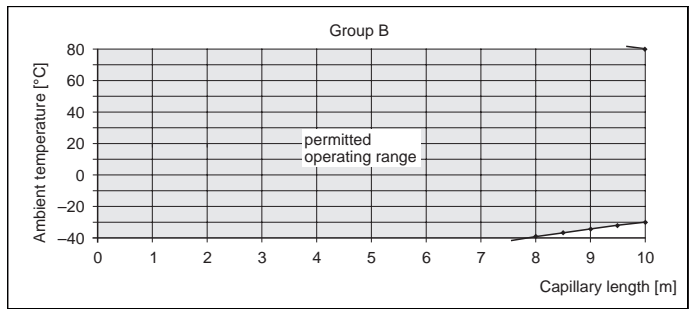

P01-FMD78xxx-05-xx-xx-xx-007

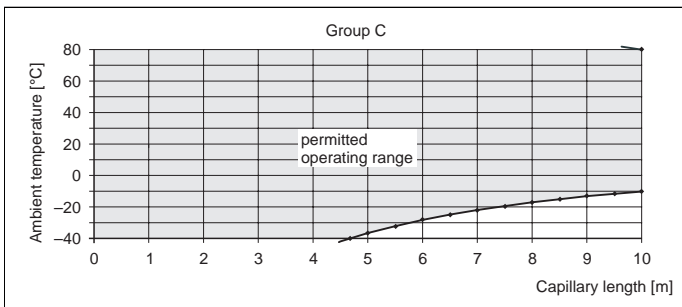

P01-FMD78xxx-05-xx-xx-xx-009

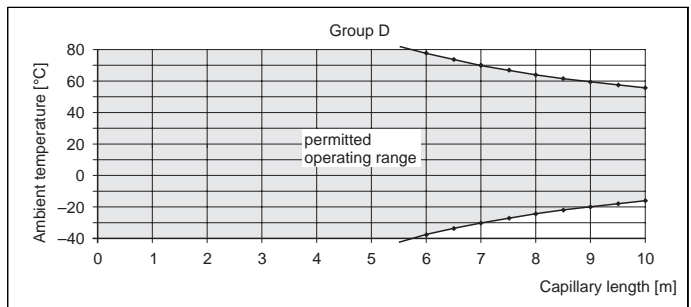

P01-FMD78xxx-05-xx-xx-xx-008

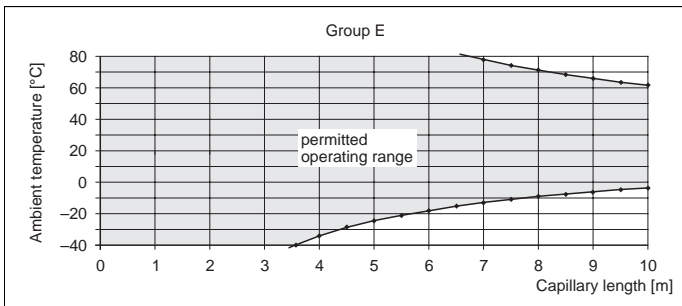

P01-FMD78xxx-05-xx-xx-xx-015

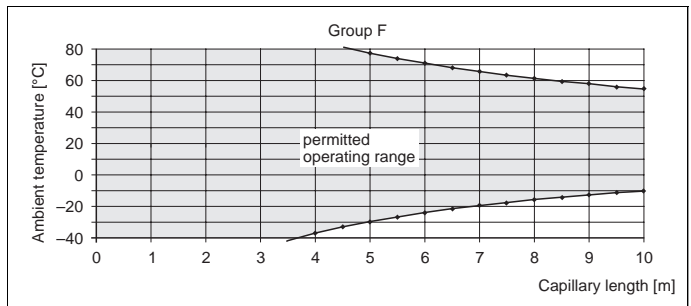

P01-FMD78xxx-05-xx-xx-xx-013

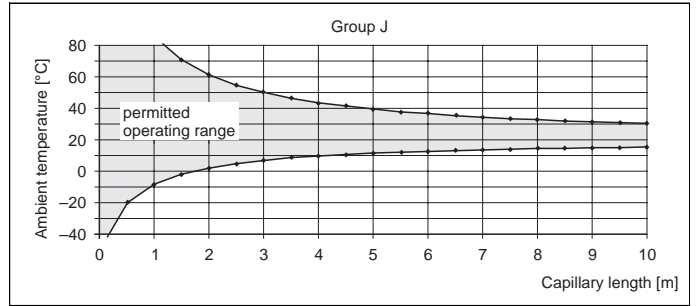
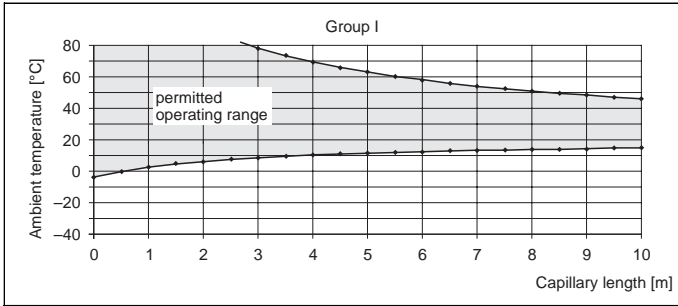
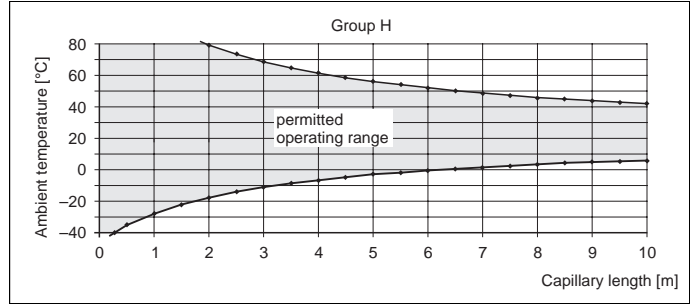
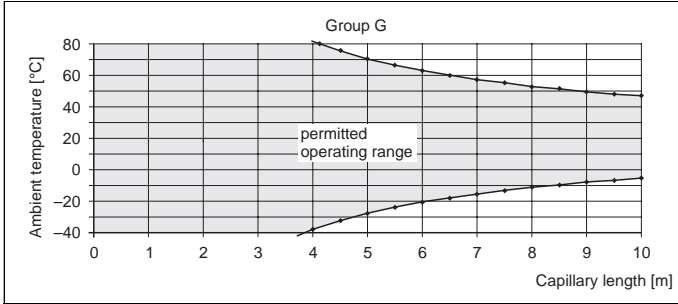

Group	Version	Diaphragm seal
A	SB	Pipe seal diaphragm Tri-Clamp, ISO 2852 DN 25 (1"), AISI 316L/1.4435
	SC	Pipe seal diaphragm Tri Clamp, ISO 2852 DN 38 (1 1/2"), AISI 316L/1.4435
	SD	Pipe seal diaphragm Tri Clamp, ISO 2852 DN 51 (2"), AISI 316L/1.4435
	GA	Thread ISO 228 G 1/2 B, PN 40, AISI 316L, Separator, PTFE seal
	RL	Thread ANSI 1/2 FNPT, PN 40, AISI 316L, Separator, PTFE seal
B	UF	Cell DN 50 PN 16-400, AISI 316L
	VF	Cell 2" 150-2500 lbs, AISI 316L
	B3	EN/DIN flange DN 50 PN 10-40 B1, AISI 316L
	AF	ANSI flange 2" 150 lbs RF, AISI 316/316L
	AR	ANSI flange 2" 300 lbs RF, AISI 316/316L
	KF	JIS flange 50 A 10 K RF, AISI 316L
	MR	DIN 11851 DN 50 PN 25, AISI 316L/1.4435
	M3	DIN 11851 DN 50 PN 25 socket, AISI 316L/1.4435
C	UH	Cell DN 80 PN 16-400, AISI 316L
	UJ	Cell DN 100 PN 16-400, AISI 316L
	VJ	Cell 4" 150-2500 lbs, AISI 316L
	B5	EN/DIN flange DN 80 PN 10-40 B1, AISI 316L
	BT	EN/DIN flange DN 100 PN 10-16 B1, AISI 316L
	B6	EN/DIN flange DN 100 PN 25-40 B1, AISI 316L
	AH	ANSI flange 4" 150 lbs RF, AISI 316/316L
	J5	ANSI flange 4" 150 lbs RF, AISI 316/316L, Extensions: 2"/4"/6"/8"
	AT	ANSI flange 4" 300 lbs RF, AISI 316/316L
	KH	JIS flange 100 A 10 K RF, AISI 316L
	MT	DIN 11851 DN 80 PN 25, AISI 316L/1.4435
	M5	DIN 11851 DN 80 PN 25 socket, AISI 316L/1.4435
D	VH	Cell 3" 150-2500 lbs, AISI 316L
	AG	ANSI flange 3" 150 lbs RF, AISI 316/316L
	AS	ANSI flange 3" 300 lbs RF, AISI 316/316L
	KL	JIS flange 80 A 10 K RF, AISI 316L
	TD	Tri-Clamp, ISO 2852 DN 51 (2"), DIN 32676 DN 50, AISI 316L/1.4435
	TF	Tri-Clamp, ISO 2852 DN 76.1 (3"), AISI 316L/1.4435
E	J4	ANSI flange 3" 150 lbs RF, AISI 316/316L, Extensions: 2"/4"/6"/8"
F	TK	DRD 65 mm, PN 25, AISI 316L/1.4435
	TR	Varivent Type N for tubes DN 40 – DN 162, PN 40, AISI 316L/1.4435
G	MS	DIN 11851 DN 65 PN 25, AISI 316L/1.4435
	M4	DIN 11851 DN 65 PN 25 socket, AISI 316L/1.4435
H	TC	Tri-Clamp, ISO 2852 DN 38 (1 – 1 1/2"), DIN 32676 DN 40, AISI 316L/1.4435
I	TB	Tri-Clamp, ISO 2852 DN 25 (1"). DIN 32676 DN 25, AISI 316L/1.4435
J	WH	Sanitary tank spud, AISI 316L/1.4435, Extensions 2"

Response time

The viscosity of the filling oil, the capillary length and the capillary internal diameter influence the frictional resistance. The greater the frictional resistance, the longer the response time.

Furthermore, the volume change of the measuring cell influences the response time. The lower the volume change of the measuring cell is, the less filling oil has to be shifted in the diaphragm seal system.

The following diagram shows typical response times (T90) for the various filling oils dependent on the measuring cell and the capillary internal diameter. The values given are in seconds per metre of capillary length and must be multiplied by the actual length of the capillary. The response time of the transmitter must also be taken into consideration.

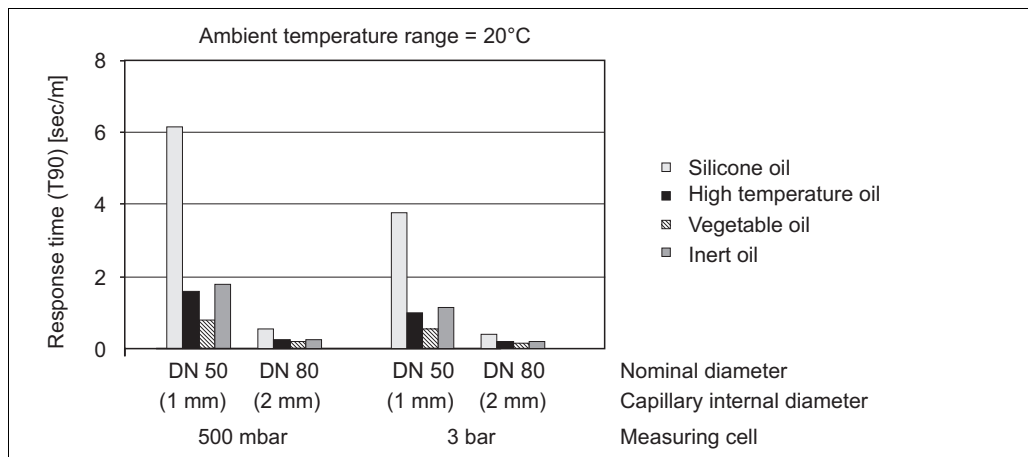

P01-FMD78xxx-05-xx-xx-xx-000

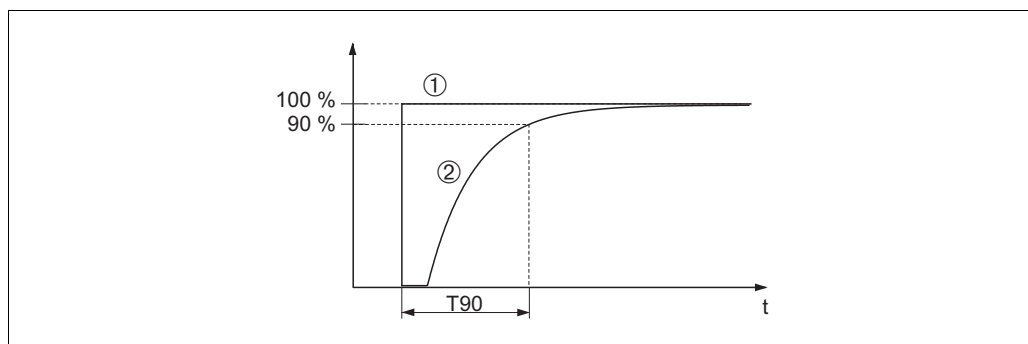

P01-xxxxxxxx-05-xx-xx-xx-000

Presentation of the response time (T90%)

- 1 Pressure step
- 2 Output signal

Minimise response time by	Comments
Larger capillary internal diameter	The temperature effect increases with increasing diameter.
Shorter capillaries	—
Filling oil with lower viscosity	<ul style="list-style-type: none"> – Observe compatibility of the filling oil with the process fluid. – Observe the filling oil operating limits.

Installation instructions

Instructions for diaphragm seal systems

- The diaphragm seal together with the transmitter form a closed, calibrated system, which is filled through ports in the diaphragm seal and in the measuring system of the transmitter. These ports are sealed and must not be opened.
- In the case of devices with diaphragm seals and capillaries, the zero point shift caused by the hydrostatic pressure of the filling liquid column in the capillaries must be taken into account when selecting the measuring cell. If a measuring cell with a small measuring cell is selected, the sensor nominal range can be overdriven as a result of position adjustment. → See the following diagram and the following example.
- When using a mounting bracket, sufficient strain relief must be allowed for in order to prevent the capillary bending down (bending radius ≥ 100 mm).
- The temperature and length of both capillaries should be the same when using two-sided diaphragm seal systems.

Selecting the measuring cell (observe the hydrostatic pressure of the filling fluid column in the capillaries!)

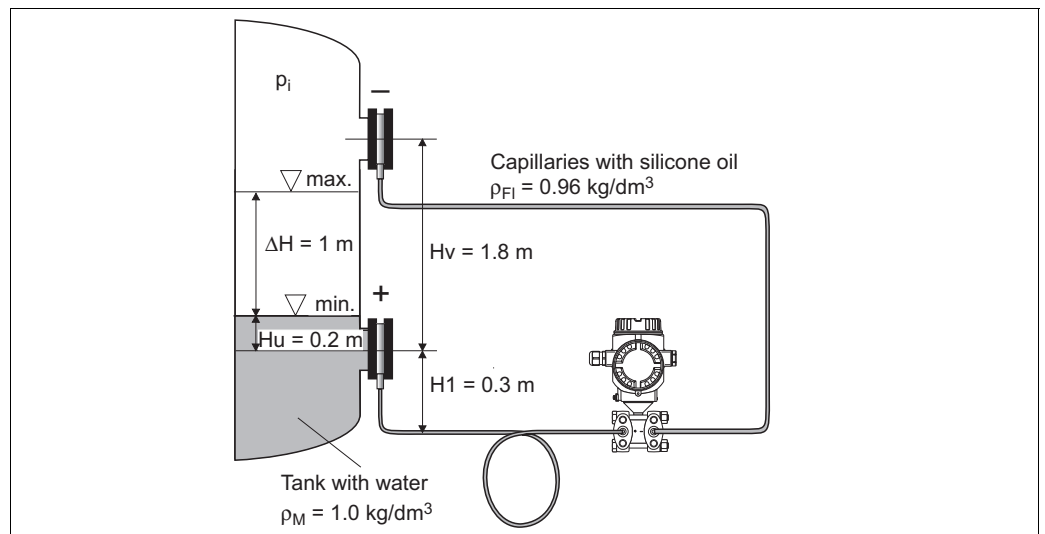

P01-FMD78xxx-11-xx-xx-xx-004.eps

Pressure on the negative side of the differential pressure transmitter (p_-) when the tank is empty (min. level)

$$\begin{aligned}
 p_- &= p_{H_v} + p_{H_1} = H_v \cdot \rho_{FI} \cdot g + H_1 \cdot \rho_{FI} \cdot g + p_i \\
 &= 1.8 \text{ m} \cdot 0.96 \frac{\text{kg}}{\text{dm}^3} \cdot 9.81 \frac{\text{m}}{\text{s}} + 0.3 \text{ m} \cdot 0.96 \frac{\text{kg}}{\text{dm}^3} \cdot 9.81 \frac{\text{m}}{\text{s}} + p_i \\
 &= 197.77 \text{ mbar} + p_i
 \end{aligned}$$

Pressure on the positive side of the differential pressure transmitter (p_+) when the tank is empty (min. level)

$$\begin{aligned}
 p_+ &= p_{H_u} + p_{H_1} = H_u \cdot \rho_M \cdot g + H_1 \cdot \rho_{FI} \cdot g + p_i \\
 &= 0.2 \text{ m} \cdot 1 \frac{\text{kg}}{\text{dm}^3} \cdot 9.81 \frac{\text{m}}{\text{s}} + 0.3 \text{ m} \cdot 0.96 \frac{\text{kg}}{\text{dm}^3} \cdot 9.81 \frac{\text{m}}{\text{s}} + p_i \\
 &= 47.87 \text{ mbar} + p_i
 \end{aligned}$$

Differential pressure at the transmitter ($\Delta p_{\text{Transmitter}}$) when the tank is empty

$$\begin{aligned}
 \Delta p_{\text{Transmitter}} &= p_+ - p_- \\
 &= 47.87 \text{ mbar} - 197.77 \text{ mbar} \\
 &= -149.90 \text{ mbar}
 \end{aligned}$$

Result:

If the tank were full, a differential pressure of -51.80 mbar would be present at the differential pressure transmitter. When the tank is empty, a differential pressure of -149.90 mbar is present. Therefore, a 500 mbar measuring cell is required for this application.

Installation instructions

In order to obtain more precise measurement results and to avoid a defect in the device, mount the capillaries as follows:

- vibration-free (in order to avoid additional pressure fluctuations)
- not in the vicinity of heating or cooling lines
- insulate at colder or warmer ambient temperatures
- with a bending radius of ≥ 100 mm.

Vacuum applications

For applications under vacuum, Endress+Hauser recommends mounting the pressure transmitter underneath the lower diaphragm seal. A vacuum load of the diaphragm seal caused by the presence of filling oil in the capillaries is hereby prevented.

When the pressure transmitter is mounted above the lower diaphragm seal, the maximum height difference H_1 in accordance with the following illustration on the left must not be exceeded. The maximum height difference is dependent on the density of the filling oil and the smallest ever pressure that is permitted to occur at the diaphragm seal on the positive side (empty tank), see the following illustration, on the right.

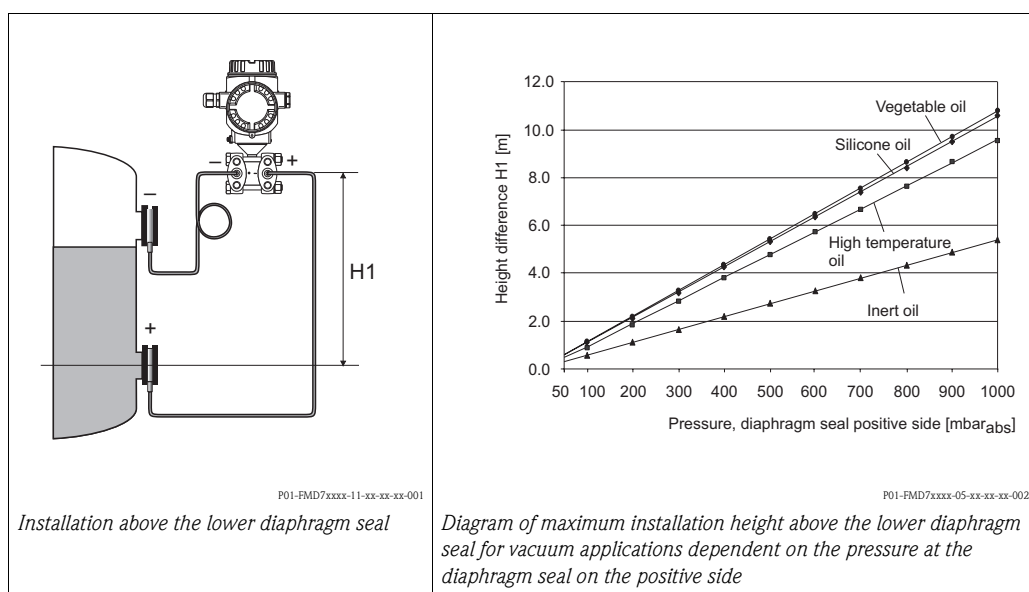

Certificates and approvals

CE mark	The device meets the legal requirements of the relevant EC directives. Endress+Hauser confirms that the device has been successfully tested by applying the CE mark.
Ex approvals	<ul style="list-style-type: none"> ■ ATEX ■ FM ■ CSA ■ NEPSI ■ IECEX ■ TIIS ■ GOST on request <p>All explosion protection data are given in separate documentation which is available upon request. The Ex documentation is supplied as standard with all devices approved for use in explosion hazardous areas. → See also page 78 ff, sections "Safety Instructions" and "Installation/Control Drawings".</p>
Marine certificate	<ul style="list-style-type: none"> ■ GL: FMD76, FMD78, PMD70, PMD75 ■ ABS: FMD76, FMD78, PMD70, PMD75
Overspill protection	WHG
CRN approvals	Some device versions have CRN approval. For a CRN-approved device, a CRN-approved process connection (→ see page 65, feature 70 "Process connection") has to be ordered with a CSA approval (→ see page 64, feature 10 "Approval"). These devices are fitted with a separate plate bearing the registration number 0F10524.5C.
Pressure Equipment Directive (PED)	<ul style="list-style-type: none"> – This measuring device corresponds to Article 3 (3) of the EC directive 97/23/EC (Pressure Equipment Directive) and has been designed and manufactured according to good engineering practice. – FMD78 with pipe diaphragm seal $\geq 1.5"/PN40$: Suitable for stable gases in group 1, category II – PMD75, PN 420 Suitable for stable gases in group 1, category I
Standards and guidelines	<p>DIN EN 60770 (IEC 60770): Transmitters for use in industrial-process control systems Part 1: Methods for inspection and routine testing</p> <p>DIN 16086: Electrical pressure measuring instruments, pressure sensors, pressure transmitters, pressure measuring instruments, concepts, specifications in data sheets</p> <p>EN 61326: Electrical equipment for measurement, control and laboratory use – EMC requirements</p>

Ordering information

PMD70

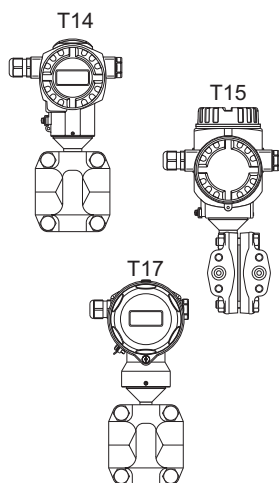
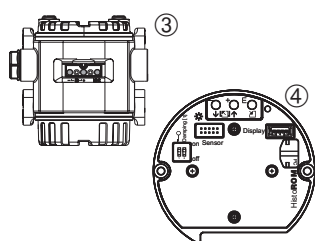
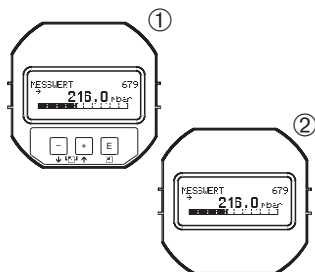

10	Approval:	
A	For non-hazardous areas	
1	ATEX II 1/2 G EEx ia IIC T6	
6	ATEX II 1/2 G EEx ia IIC T6, overspill protection WHG	
2	ATEX II 1/2 D	
4	ATEX II 1/3 D	
8	ATEX II 1 GD EEx ia IIC T6	
3	ATEX II 1/2 GD EEx ia IIC T6	
7	ATEX II 3 G EEx nA II T6	
S	FM IS, Class I, II, III Division 1, Groups A – G; NI Class I Division 2, Groups A – D; AEx ia	
Q	FM DIP, Class II, III Division 1, Groups E – G	
R	FM NI, Class I, Division 2, Groups A – D	
U	CSA IS, Class I, II, III Division 1, Groups A – G; Class I Division 2, Groups A – D, Ex ia	
W	CSA Class II, III Division 1, Groups E – G (Dust-Ex)	
H	NEPSI Ex ia IIC T6	
I	IECEx Zone 0/1 Ex ia IIC T6	
20	Output; Operation:	
A	4...20 mA HART, SIL operation outside, LCD (→ see Fig. ①, ③)	
B	4...20 mA HART, SIL operation inside, LCD (→ see Fig. ①, ④)	
C	4...20 mA HART, SIL operation inside (→ see Fig. ④)	
M	PROFIBUS PA, operation outside, LCD (→ see Fig. ②, ③)	
N	PROFIBUS PA, operation inside, LCD (→ see Fig. ②, ④)	
O	PROFIBUS PA, operation inside (→ see Fig. ④)	
P	FOUNDATION Fieldbus, operation outside, LCD (→ see Fig. ②, ③)	
Q	FOUNDATION Fieldbus, operation inside, LCD (→ see Fig. ②, ④)	
R	FOUNDATION Fieldbus, operation inside (→ see Fig. ④)	
30	Housing; Cable entry; Protection:	
A	Aluminium T14 housing, optional display on the side, IP 66/67/NEMA 6P, Gland M 20x1.5	
B	Aluminium T14 housing, optional display on the side, IP 66/67/NEMA 6P, Thread G 1/2	
C	Aluminium T14 housing, optional display on the side, IP 66/67/NEMA 6P, Thread 1/2 NPT	
D	Aluminium T14 housing, optional display on the side, IP 66/67/NEMA 6P, M12x1 PA plug	
E	Aluminium T14 housing, optional display on the side, IP 66/67/NEMA 6P, 7/8" FF plug	
F	Aluminium T14 housing, optional display on the side, IP 65/NEMA 4X, Han7D plug, 90°	
J	Aluminium T15 housing, optional display on the top, IP 66/67/NEMA 6P, Gland M 20x1.5	
K	Aluminium T15 housing, optional display on the top, IP 66/67/NEMA 6P, Thread G 1/2	
L	Aluminium T15 housing, optional display on the top, IP 66/67/NEMA 6P, Thread 1/2 NPT	
M	Aluminium T15 housing, optional display on the top, IP 66/67/NEMA 6P, M12x1 PA plug	
N	Aluminium T15 housing, optional display on the top, IP 66/67/NEMA 6P, 7/8" FF plug	
P	Aluminium T15 housing, optional display on the top, IP 65/NEMA 4X, Han7D plug, 90°	
1	AISI 316L T14 housing, optional display on the side, IP 66/67/NEMA 6P, Gland M 20x1.5	
2	AISI 316L T14 housing, optional display on the side, IP 66/67/NEMA 6P, Thread G 1/2	
3	AISI 316L T14 housing, optional display on the side, IP 66/67/NEMA 6P, Thread 1/2 NPT	
4	AISI 316L T14 housing, optional display on the side, IP 66/67/NEMA 6P, M 12x1 PA plug	
5	AISI 316L T14 housing, optional display on the side, IP 66/67/NEMA 6P, 7/8" FF plug	
6	AISI 316L T14 housing, optional display on the side, IP 65/NEMA 4X, Han7D plug, 90°	
R	AISI 316L T17 housing, optional display on the side, IP 66/68/NEMA 6P, Gland M 20x1.5	
S	AISI 316L T17 housing, optional display on the side, IP 66/68/NEMA 6P, Thread G 1/2	
T	AISI 316L T17 housing, optional display on the side, IP 66/68/NEMA 6P, Thread 1/2 NPT	
U	AISI 316L T17 housing, optional display on the side, IP 66/68/NEMA 6P, M 12x1 PA plug	
V	AISI 316L T17 housing, optional display on the side, IP 66/68/NEMA 6P, 7/8" FF plug	
Z	Housing: see additional specifications	
40	Nominal range; PN:	
	Nominal value	PN
7B	25 mbar/2500 Pa/0.375 psi	10 bar/1 MPa/150 psi
7D	100 mbar/10 kPa/1.5 psi	16 bar/1,6 MPa/240 psi
7F	500 mbar/50 kPa/7.5 psi	100 bar/10 MPa/1500 psi
7H	3 bar/300 kPa/45 psi	100 bar/10 MPa/1500 psi
78	Prepared mounting DELTATOP/DELTASET	
PMD70		order code

→ For continuation of PMD70 ordering information, see the following page.

PMD70 (continued)

50					Calibration; Unit:		
	1	Nominal range; mbar/bar					
	2	Nominal range; kPa/MPa					
	3	Nominal range; mmH ₂ O/mH ₂ O					
	4	Nominal range; inH ₂ O/ftH ₂ O					
	6	Nominal range; psi					
	8	Adjusted for Deltatop/Deltaset; see additional specification					
	B	Customised; see additional specification					
	C	Factory certificate 5-point; see additional specification					
	D	DKD certificate; see additional specification					
	K	Platinum; see additional specification					
	L	Platinum and factory certificate 5-point; see additional specification					
	M	Platinum and DKD certificate; see additional specification					
	70					Process connection; Material:	
		B	1/4 – 18 NPT IEC 61518, mounting: 7/16 – 20 UNF, C22.8 (CRN)				
D		1/4 – 18 NPT IEC 61518, mounting: 7/16 – 20 UNF, AISI 316L (CRN)					
F		1/4 – 18 NPT IEC 61518, mounting: 7/16 – 20 UNF, Alloy C (CRN)					
G		1/4 – 18 NPT IEC 61518, mounting: 7/16 – 20 UNF, PVDF					
U		RC 1/4 mounting: 7/16 – 20 UNF, AISI 316L (CRN)					
1		1/4 – 18 NPT, mounting: PN 160: M10, C22.8 (CRN)					
2		1/4 – 18 NPT, mounting: PN 160: M10, AISI 316L (CRN)					
3		1/4 – 18 NPT, mounting: PN 160: M10, Alloy C (CRN)					
80						Seal:	
	A	FKM Viton					
	B	EPDM					
	D	Kalrez					
	E	Chemraz					
	1	FKM Viton, degreased					
2	FKM Viton, cleaned for oxygen service						
100					Additional option 1:		
	A	not selected					
	E	SIL2/IEC 61508 Declaration of conformity					
	B	Material test certificate for wetted components, inspection certificate as per EN 10204 3.1 acc. to specification 52005759					
	M	Overvoltage protection					
	N	HistoROM/M-DAT					
	S	GL/ABS marine certificate					
	V	Mounting on shut-off valve from above					
	W	Mounting on shut-off valve from below					
	2	Test report acc. to EN10204 2.2					
	3	Routine test with certificate, inspection certificate as per EN 10204 3.1					
	4	Overpressure test with certificate, inspection certificate as per EN 10204 3.1					
110					Additional option 2:		
	A	not selected					
	E	SIL2/IEC 61508 Declaration of conformity					
	B	Material test certificate for wetted components, inspection certificate as per EN10204 3.1 acc. to specification 52005759					
	K	Vent valves (2 pieces), Alloy C					
	M	Overvoltage protection					
	N	HistoROM/M-DAT					
	R	Screws 7/16 UNF, length 1 1/2" (4 pieces)					
	S	GL/ABS marine certificate					
	U	Mounting bracket for wall/pipe, AISI 304					
	2	Test report acc. to EN10204 2.2					
	3	Routine test with certificate, inspection certificate as per EN 10204 3.1					
	4	Overpressure test with certificate, inspection certificate as per EN 10204 3.1					
5	Helium leak test EN 1518 with test certificate, inspection certificate as per EN 10204 3.1						
PMD70					complete order code		

PMD75

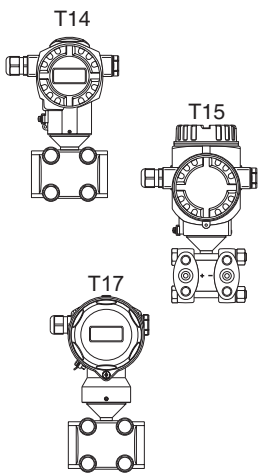
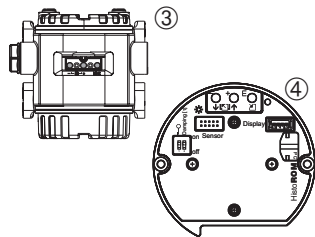
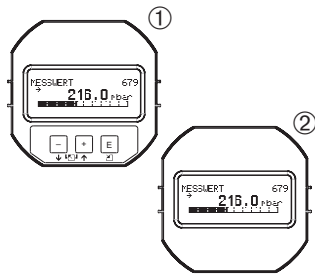

10	Approval:
	<p>A For non-hazardous areas</p> <p>1 ATEX II 1/2 G EEx ia IIC T6</p> <p>6 ATEX II 1/2 G EEx ia IIC T6, overspill protection WHG</p> <p>2 ATEX II 1/2 D</p> <p>4 ATEX II 1/3 D</p> <p>8 ATEX II 1 GD EEx ia IIC T6</p> <p>3 ATEX II 1/2 GD EEx ia IIC T6</p> <p>5 ATEX II 2 G EEx d IIC T6</p> <p>7 ATEX II 3 G EEx nA II T6</p> <p>S FM IS, Class I, II, III Division 1, Groups A – G; NI Class I Division 2, Groups A – D; AEx ia</p> <p>T FM XP, Class I Division 1, Groups A – D; AEx d</p> <p>Q FM DIP, Class II, III Division 1, Groups E – G</p> <p>R FM NI, Class I, Division 2, Groups A – D</p> <p>U CSA IS, Class I, II, III Division 1, Groups A – G; Class I Division 2, Groups A – D, Ex ia</p> <p>V CSA XP, Class I Division 1, Groups B – D; Ex d</p> <p>W CSA Class II, III Division 1, Groups E – G (Dust-Ex)</p> <p>G NEPSI Exd IIC T6</p> <p>H NEPSI Ex ia IIC T6</p> <p>I IECEx Zone 0/1 Ex ia IIC T6</p> <p>K TIIS Ex ia IIC T6</p> <p>L TIIS Ex d IIC T6</p> <p>B Combined certificates: ATEX II 1/2 G EEx ia IIC T6 + II G EEx d IIC T6</p> <p>C Combined certificates: FM IS and XP Class I Division 1, Groups A – D</p> <p>D Combined certificates: CSA IS and XP Class I Division 1, Groups A – D</p> <p>E Combined certificates: FM/CSA IS and XP Class I Division 1, Groups A – D</p>
20	Output; Operation:
	<p>A 4...20 mA HART, SIL operation outside, LCD (→ see Fig. ①, ③)</p> <p>B 4...20 mA HART, SIL operation inside, LCD (→ see Fig. ①, ④)</p> <p>C 4...20 mA HART, SIL operation inside (→ see Fig. ④)</p> <p>M PROFIBUS PA, operation outside, LCD (→ see Fig. ②, ③)</p> <p>N PROFIBUS PA, operation inside, LCD (→ see Fig. ②, ④)</p> <p>O PROFIBUS PA, operation inside (→ see Fig. ④)</p> <p>P FOUNDATION Fieldbus, operation outside, LCD (→ see Fig. ②, ③)</p> <p>Q FOUNDATION Fieldbus, operation inside, LCD (→ see Fig. ②, ④)</p> <p>R FOUNDATION Fieldbus, operation inside (→ see Fig. ④)</p>
30	Housing; Cable entry, Protection:
	<p>A Aluminium T14 housing, optional display on the side, IP 66/67/NEMA 6P, Gland M 20x1.5</p> <p>B Aluminium T14 housing, optional display on the side, IP 66/67/NEMA 6P, Thread G 1/2</p> <p>C Aluminium T14 housing, optional display on the side, IP 66/67/NEMA 6P, Thread 1/2 NPT</p> <p>D Aluminium T14 housing, optional display on the side, IP 66/67/NEMA 6P, M12x1 PA plug</p> <p>E Aluminium T14 housing, optional display on the side, IP 66/67/NEMA 6P, 7/8" FF plug</p> <p>F Aluminium T14 housing, optional display on the side, IP 65/NEMA 4X, Han7D plug, 90°</p> <p>J Aluminium T15 housing, optional display on the top, IP 66/67/NEMA 6P, Gland M 20x1.5</p> <p>K Aluminium T15 housing, optional display on the top, IP 66/67/NEMA 6P, Thread G 1/2</p> <p>L Aluminium T15 housing, optional display on the top, IP 66/67/NEMA 6P, Thread 1/2 NPT</p> <p>M Aluminium T15 housing, optional display on the top, IP 66/67/NEMA 6P, M 12x1 PA plug</p> <p>N Aluminium T15 housing, optional display on the top, IP 66/67/NEMA 6P, 7/8" FF plug</p> <p>P Aluminium T15 housing, optional display on the top, IP 65/NEMA 4X, Han7D plug, 90°</p> <p>1 AISI 316L T14 housing, optional display on the side, IP 66/67/NEMA 6P, Gland M 20x1.5</p> <p>2 AISI 316L T14 housing, optional display on the side, IP 66/67/NEMA 6P, Thread G 1/2</p> <p>3 AISI 316L T14 housing, optional display on the side, IP 66/67/NEMA 6P, Thread 1/2 NPT</p> <p>4 AISI 316L T14 housing, optional display on the side, IP 66/67/NEMA 6P, M 12x1 PA plug</p> <p>5 AISI 316L T14 housing, optional display on the side, IP 66/67/NEMA 6P, 7/8" FF plug</p> <p>6 AISI 316L T14 housing, optional display on the side, IP 65/NEMA 4X, Han7D plug, 90°</p> <p>R AISI 316L T17 housing, optional display on the side, IP 66/68/NEMA 6P, Gland M 20x1.5</p> <p>S AISI 316L T17 housing, optional display on the side, IP 66/68/NEMA 6P, Thread G 1/2</p> <p>T AISI 316L T17 housing, optional display on the side, IP 66/68/NEMA 6P, Thread 1/2 NPT</p> <p>U AISI 316L T17 housing, optional display on the side, IP 66/68/NEMA 6P, M 12x1 PA plug</p> <p>V AISI 316L T17 housing, optional display on the side, IP 66/68/NEMA 6P, 7/8" FF plug</p> <p>Z Housing: see additional specifications</p>
PMD75	order code

→ For continuation of PMD75 ordering information, see the following page.

PMD75 (continued)

40					Nominal range; PN:		
					Nominal value	PN	
					7B	10 mbar/1 kPa/0.15 psi	160 bar/16 MPa/2400 psi
					7C	30 mbar/3 kPa/0.45 psi	160 bar/16 MPa/2400 psi
					7D	100 mbar/10 kPa/1.5 psi	160 bar/16 MPa/2400 psi
					7F	500 mbar/50 kPa/7.5 psi	160 bar/16 MPa/2400 psi
					7H	3 bar/300 kPa/45 psi	160 bar/16 MPa/2400 psi
					7L	16 bar/1.6 MPa/240 psi	160 bar/16 MPa/2400 psi
					7M	40 bar/4 MPa/600 psi	160 bar/16 MPa/2400 psi
					8F	500 mbar/50 kPa/7.5 psi	420 bar/42 MPa/6300 psi
					8H	3 bar/300 kPa/45 psi	420 bar/42 MPa/6300 psi
					8L	16 bar/1.6 MPa/240 psi	420 bar/42 MPa/6300 psi
					8M	40 bar/4 MPa/600 psi	420 bar/42 MPa/6300 psi
				78	Prepared for Deltatop/Deltaset; PN = 160 bar		
				88	Prepared for Deltatop/Deltaset; PN = 420 bar		
50					Calibration; Unit:		
					1	Nominal range; mbar/bar	
					2	Nominal range; kPa/MPa	
					3	Nominal range; mmH ₂ O/mH ₂ O	
					4	Nominal range; inH ₂ O/ftH ₂ O	
					6	Nominal range; psi	
					8	Adjusted for Deltatop/Deltaset; see additional specification	
					B	Customised; see additional specification	
					C	Factory certificate 5-point; see additional specification	
					D	DKD certificate; see additional specification	
					K	Platinum; see additional specification	
					L	Platinum and factory certificate 5-point; see additional specification	
					M	Platinum and DKD certificate; see additional specification	
60					Membrane material:		
					1	AISI 316L	
					2	Alloy C	
					3	Monel	
					5	Tantal	
					6	AISI 316L with Gold-Rhodium coating	
70					Process connection; Material:		
					B	1/4 – 18 NPT IEC 61518, mounting: 7/16 – 20 UNF, C22.8 (CRN)	
					C	1/4 – 18 NPT IEC 61518, mounting: 7/16 – 20 UNF, C22.8, side vent, including 4 fastening bolt connections (AISI 316L) mounted	
					D	1/4 – 18 NPT IEC 61518, mounting: 7/16 – 20 UNF, AISI 316L (CRN)	
					E	1/4 – 18 NPT IEC 61518, mounting: 7/16 – 20 UNF, AISI 316L, side vent, including 4 fastening bolt connections (AISI 316L) mounted	
					F	1/4 – 18 NPT IEC 61518, mounting: 7/16 – 20 UNF, Alloy C (CRN), without screws/vents	
					H	1/4 – 18 NPT IEC 61518, mounting: 7/16 – 20 UNF, Alloy C, side vent, without screws/vents	
					U	RC 1/4 mounting: 7/16 – 20 UNF, AISI 316L (CRN)	
					V	RC 1/4 mounting: 7/16 – 20 UNF, C22.8, side vent, including 4 fastening bolt connections (AISI 316L) mounted	
					W	Prepared for diaphragm seal mount	
					1	1/4 – 18 NPT, mounting: PN 160: M10, PN 420: M12, C22.8 (CRN)	
					2	1/4 – 18 NPT, mounting: PN 160: M10, PN 420: M12, AISI 316L (CRN)	
					3	1/4 – 18 NPT, mounting: PN 160: M10, PN 420: M12, Alloy C (CRN)	
80					Seal:		
					A	FKM Viton	
					C	PTFE	
					F	NBR	
					K	Copper seal ring, cleaned for oxygen service	
					1	FKM Viton, degreased	
					2	FKM Viton, cleaned for oxygen service	
					3	PTFE, cleaned for oxygen service	
				H	Copper seal ring		
PMD75						order code	

→ For continuation of PMD75 ordering information, see the following page.

PMD75 (continued)

100													Additional option 1:
													A not selected
													E SIL2/IEC 61508 Declaration of conformity
													B Material test certificate for wetted components, inspection certificate as per EN 10204 3.1 acc. to specification 52005759
													C NACE MR0175 (wetted parts)
													D Material test certificate for wetted components as per EN 10204 3.1 and NACE MR0175 material, inspection certificate as per EN 10204 acc. to specification 52010806
													M Overvoltage protection
													N HistoROM/M-DAT
													S GL/ABS marine certificate
													V Mounting on shut-off valve from above
													W Mounting on shut-off valve from below
													2 Test report acc. to EN10204 2.2
													3 Routine test with certificate, inspection certificate as per EN 10204 3.1
													4 Overpressure test with certificate, inspection certificate as per EN 10204 3.1
110													Additional option 2:
													A not selected
													E SIL2/IEC 61508 Declaration of conformity
													B Material test certificate for wetted components, inspection certificate as per EN 10204 3.1 acc. to specification 52005759
													K Vent valves (2 pieces), Alloy C
													L Vent valves (4 pieces), Alloy C
													M Overvoltage protection
													N HistoROM/M-DAT
													R Screws 7/16 UNF, length 1 1/2" (4 pieces)
													S GL/ABS marine certificate
													U Mounting bracket for wall/pipe, AISI 304
													2 Test report acc. to EN10204 2.2
													3 Routine test with certificate, inspection certificate as per EN 10204 3.1
													4 Overpressure test with certificate, inspection certificate as per EN 10204 3.1
													5 Helium leak test EN 1518 with test certificate inspection certificate as per EN 10204 3.1
PMD75													complete order code

FMD76

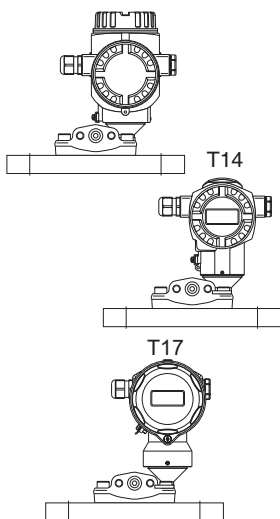
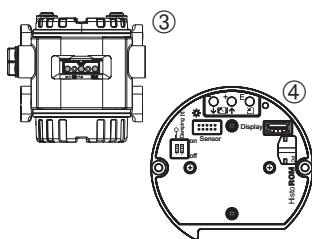
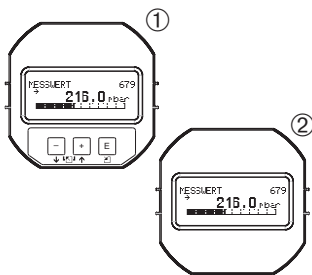

10		Approval:
A		For non-hazardous areas
1		ATEX II 1/2 G EEx ia IIC T6
6		ATEX II 1/2 G EEx ia IIC T6, overspill protection WHG
2		ATEX II 1/2 D EEx ia IIC T6
8		ATEX II 1 GD EEx ia IIC T6
3		ATEX II 1/2 GD EEx ia IIC T6
7		ATEX II 3 G EEx nA II T6
S		FM IS, Class I, II, III Division 1, Groups A – G; NI Class I Division 2, Groups A – D; AEx ia
R		FM NI, Class I, Division 2, Groups A – D
U		CSA IS, Class I, II, III Division 1, Groups A – G; Class I Division 2, Groups A – D, Ex ia
H		NEPSI Ex ia IIC T6
I		IECEx Zone 0/1 Ex ia IIC T6

20		Output; Operation:
A		4...20 mA HART, SIL operation outside, LCD (→ see Fig. ①, ③)
B		4...20 mA HART, SIL operation inside, LCD (→ see Fig. ①, ④)
C		4...20 mA HART, SIL operation inside (→ see Fig. ④)
M		PROFIBUS PA, operation outside, LCD (→ see Fig. ②, ③)
N		PROFIBUS PA, operation inside, LCD (→ see Fig. ②, ④)
O		PROFIBUS PA, operation inside (→ see Fig. ④)
P		FOUNDATION Fieldbus, operation outside, LCD (→ see Fig. ②, ③)
Q		FOUNDATION Fieldbus, operation inside, LCD (→ see Fig. ②, ④)
R		FOUNDATION Fieldbus, operation inside (→ see Fig. ④)

30		Housing; Cable entry, Protection:
A		Aluminium T14 housing, optional display on the side, IP 66/67/NEMA 6P, Gland M 20x1.5
B		Aluminium T14 housing, optional display on the side, IP 66/67/NEMA 6P, Thread G 1/2
C		Aluminium T14 housing, optional display on the side, IP 66/67/NEMA 6P, Thread 1/2 NPT
D		Aluminium T14 housing, optional display on the side, IP66/67/NEMA 6P, M12x1 PA plug
E		Aluminium T14 housing, optional display on the side, IP 66/67/NEMA 6P, 7/8" FF plug
F		Aluminium T14 housing, optional display on the side, IP 65/NEMA 4X, Han7D plug, 90°
J		Aluminium T15 housing, optional display on the top, IP 66/67/NEMA 6P, Gland M 20x1.5
K		Aluminium T15 housing, optional display on the top, IP 66/67/NEMA 6P, Thread G 1/2
L		Aluminium T15 housing, optional display on the top, IP 66/67/NEMA 6P, Thread 1/2 NPT
M		Aluminium T15 housing, optional display on the top, IP 66/67/NEMA 6P, M 12x1 PA plug
N		Aluminium T15 housing, optional display on the top, IP 66/67/NEMA 6P, 7/8" FF plug
P		Aluminium T15 housing, optional display on the top, IP 65/NEMA 4X, Han7D plug, 90°
1		AISI 316L T14 housing, optional display on the side, IP 66/67/NEMA 6P, Gland M 20x1.5
2		AISI 316L T14 housing, optional display on the side, IP 66/67/NEMA 6P, Thread G 1/2
3		AISI 316L T14 housing, optional display on the side, IP 66/67/NEMA 6P, Thread 1/2 NPT
4		AISI 316L T14 housing, optional display on the side, IP 66/67/NEMA 6P, M 12x1 PA plug
5		AISI 316L T14 housing, optional display on the side, IP 66/67/NEMA 6P, 7/8" FF plug
6		AISI 316L T14 housing, optional display on the side, IP 65/NEMA 4X, Han7D plug, 90°
R		AISI 316L T17 housing, optional display on the side, IP 66/68/NEMA 6P, Gland M 20x1.5
S		AISI 316L T17 housing, optional display on the side, IP 66/68/NEMA 6P, Thread G 1/2
T		AISI 316L T17 housing, optional display on the side, IP 66/68/NEMA 6P, Thread 1/2 NPT
U		AISI 316L T17 housing, optional display on the side, IP 66/68/NEMA 6P, M 12x1 PA plug
V		AISI 316L T17 housing, optional display on the side, IP 66/68/NEMA 6P, 7/8" FF plug
Z		Housing: see additional specifications

40		Nominal range; PN:	
		Nominal value	PN
		7D 100 mbar/10 kPa/1.5 psi	16 bar/1,6 MPa/240 psi
		7F 500 mbar/50 kPa/7.5 psi	100 bar/10 MPa/1500 psi
		7H 3 bar/300 kPa/45 psi	100 bar/10 MPa/1500 psi

FMD76														order code
-------	--	--	--	--	--	--	--	--	--	--	--	--	--	------------

→ For continuation of FMD76 ordering information, see the following page.

FMD76 (continued)

50					Calibration; Unit:	
						1 Nominal range; mbar/bar 2 Nominal range; kPa/MPa 3 Nominal range; mmH ₂ O/mH ₂ O 4 Nominal range; inH ₂ O/ftH ₂ O 6 Nominal range; psi B Customised; see additional specification C Factory certificate 5-point; see additional specification D DKD certificate; see additional specification K Platinum; see additional specification L Platinum and factory certificate 5-point; see additional specification M Platinum and DKD certificate; see additional specification
70					Process connection low-pressure side; Material; Seal:	
						Mounting: 7/16 – 20 UNF B 1/4 – 18 NPT IEC 61518, C22.8, FKM Viton (CRN) D 1/4 – 18 NPT IEC 61518, AISI 316L, FKM Viton (CRN) F 1/4 – 18 NPT IEC 61518, Alloy C, FKM Viton (CRN) G 1/4 – 18 NPT IEC 61518, PVDF, FKM Viton, Safety instructions, observe electrostatic charge. K 1/4 – 18 NPT IEC 61518, AISI 316L, EPDM (CRN) L 1/4 – 18 NPT IEC 61518, Alloy C, EPDM (CRN) M 1/4 – 18 NPT IEC 61518, AISI 316L, Kalrez (CRN) N 1/4 – 18 NPT IEC 61518, Alloy C, Kalrez (CRN) P 1/4 – 18 NPT IEC 61518, AISI 316L, Chemraz (CRN) Q 1/4 – 18 NPT IEC 61518, Alloy C, Chemraz (CRN) S 1/4 – 18 NPT IEC 61518, AISI 316L, FKM Viton, degreased (CRN) T 1/4 – 18 NPT IEC 61518, AISI 316L, FKM Viton, cleaned for oxygen service (CRN) U RC 1/4, AISI 316L, FKM Viton (CRN)
80					Process connection high-pressure side; Material:	
						EN/DIN flanges B DN 80 PN 10-40 B1, AISI 316L D DN 80 PN 10-40, AISI 316L with ECTFE coating Safety instructions, observe electrostatic charge! E DN 80 PN 10-40 B1, Alloy C276 F DN 100 PN 10-16 B1, AISI 316L G DN 100 PN 25-40 B1, AISI 316L H DN 100 PN 25-40, AISI 316L with ECTFE coating Safety instructions, observe electrostatic charge! J DN 100 PN 25-40 B1, Alloy C276 L DN 100 PN 10-16, AISI 316L with ECTFE coating Safety instructions, observe electrostatic charge! M DN 100 PN 10-16 B1, Alloy C276 ANSI flanges P 3" 150 lbs RF, AISI 316/316L (CRN) R 3" 150 lbs, AISI 316/316L with ECTFE coating Safety instructions, observe electrostatic charge! S 3" 150 lbs RF, Alloy C276 (CRN) T 4" 150 lbs RF, AISI 316/316L (CRN) U 4" 150 lbs, AISI 316/316L with ECTFE coating Safety instructions, observe electrostatic charge! V 4" 150 lbs RF, Alloy C276 (CRN) W 4" 300 lbs RF, AISI 316/316L (CRN) JIS flanges 1 10K 80A RF, AISI 316L 3 10K 80A RF, Alloy C276 4 10K 100A RF, AISI 316L Hygienic connection 5 Sanitary tank spud, AISI 316L, extension 2"
FMD76						order code

→ For continuation of FMD76 ordering information, see the following page.

FMD76 (continued)

100										Additional option 1:	
										A	not selected
										E	SIL2/IEC 61508 Declaration of conformity
										B	Material test certificate for wetted components, inspection certificate as per EN 10204 3.1 acc. to specification 52005759
										M	Overvoltage protection
										N	HistoROM/M-DAT
										S	GL/ABS marine certificate
										2	Test report acc. to EN10204 2.2
										3	Routine test with certificate, inspection certificate as per EN 10204 3.1
										4	Overpressure test with certificate, inspection certificate as per EN 10204 3.1
110										Additional option 2:	
										A	not selected
										E	SIL2/IEC 61508 Declaration of conformity
										K	Vent valves (2 pieces), Alloy C
										M	Overvoltage protection
										N	HistoROM/M-DAT
										R	Screws 7/16 UNF, length 1 1/2" (4 pieces)
										S	GL/ABS marine certificate
										U	Mounting bracket for wall/pipe, AISI 304
										2	Test report acc. to EN10204 2.2
										3	Routine test with certificate, inspection certificate as per EN 10204 3.1
										4	Overpressure test with certificate, inspection certificate as per EN 10204 3.1
										5	Helium leak test EN 1518 with test certificate, inspection certificate as per EN 10204 3.1
FMD76										complete order code	

FMD77

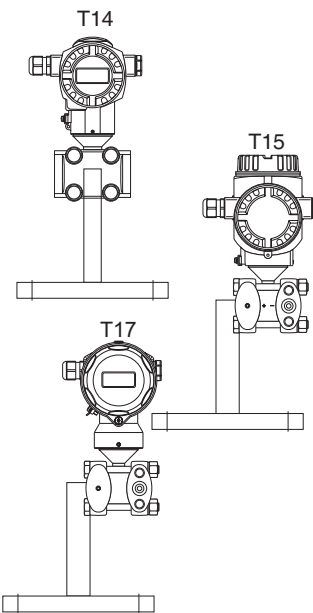
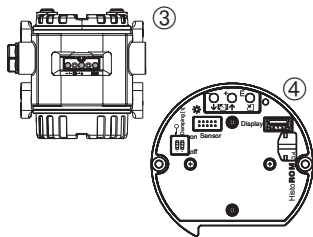
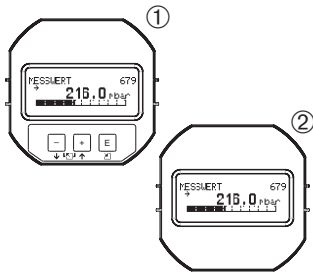

10	Approval:
	<p>A For non-hazardous areas</p> <p>1 ATEX II 1/2 G EEx ia IIC T6</p> <p>6 ATEX II 1/2 G EEx ia IIC T6, overspill protection WHG</p> <p>2 ATEX II 1/2 D</p> <p>4 ATEX II 1/3 D</p> <p>8 ATEX II 1 GD EEx ia IIC T6</p> <p>3 ATEX II 1/2 GD EEx ia IIC T6</p> <p>5 ATEX II 2 G EEx d IIC T6</p> <p>7 ATEX II 3 G EEx nA II T6</p> <p>S FM IS, Class I, II, III Division 1, Groups A – G; NI Class I Division 2, Groups A – D; AEx ia</p> <p>T FM XP, Class I Division 1, Groups A – D; AEx ia</p> <p>Q FM DIP, Class II, III Division 1, Groups E – G</p> <p>R FM NI, Class I, Division 2, Groups A – D</p> <p>U CSA IS, Class I, II, III Division 1, Groups A – G; Class I Division 2, Groups A – D, Ex ia</p> <p>V CSA XP, Class I Division 1, Groups B – D; Ex d</p> <p>W CSA Class II, III Division 1, Groups E – G (Dust-Ex)</p> <p>G NEPSI Ex d IIC T6</p> <p>H NEPSI Ex ia IIC T6</p> <p>I IECEX Zone 0/1 Ex ia IIC T6</p> <p>K TIIS Ex ia IIC T6</p> <p>L TIIS Ex d IIC T6</p> <p>B Combined certificates: ATEX II 1/2 G EEx ia IIC T6 + II G EEx d IIC T6</p> <p>C Combined certificates: FM IS and XP Class I Division 1, Groups A – D</p> <p>D Combined certificates: CSA IS and XP Class I Division 1, Groups A – D</p> <p>E Combined certificates: FM/CSA IS and XP Class I Division 1, Groups A – D</p>
20	Output; Operation:
	<p>A 4...20 mA HART, SIL operation outside, LCD (→ see Fig. ①, ③)</p> <p>B 4...20 mA HART, SIL operation inside, LCD (→ see Fig. ①, ④)</p> <p>C 4...20 mA HART, SIL operation inside (→ see Fig. ④)</p> <p>M PROFIBUS PA, operation outside, LCD (→ see Fig. ②, ③)</p> <p>N PROFIBUS PA, operation inside, LCD (→ see Fig. ②, ④)</p> <p>O PROFIBUS PA, operation inside (→ see Fig. ④)</p> <p>P FOUNDATION Fieldbus, operation outside, LCD (→ see Fig. ②, ③)</p> <p>Q FOUNDATION Fieldbus, operation inside, LCD (→ see Fig. ②, ④)</p> <p>R FOUNDATION Fieldbus, operation inside (→ see Fig. ④)</p>
30	Housing; Cable entry, Protection:
	<p>A Aluminium T14 housing, optional display on the side, IP 66/67/NEMA 6P, Gland M 20x1.5</p> <p>B Aluminium T14 housing, optional display on the side, IP 66/67/NEMA 6P, Thread G 1/2</p> <p>C Aluminium T14 housing, optional display on the side, IP 66/67/NEMA 6P, Thread 1/2 NPT</p> <p>D Aluminium T14 housing, optional display on the side, IP 66/67/NEMA 6P, M12x1 PA plug</p> <p>E Aluminium T14 housing, optional display on the side, IP 66/67/NEMA 6P, 7/8" FF plug</p> <p>F Aluminium T14 housing, optional display on the side, IP 65/NEMA 4X, Han7D plug, 90°</p> <p>J Aluminium T15 housing, optional display on the top, IP 66/67/NEMA 6P, Gland M 20x1.5</p> <p>K Aluminium T15 housing, optional display on the top, IP 66/67/NEMA 6P, Thread G 1/2</p> <p>L Aluminium T15 housing, optional display on the top, IP 66/67/NEMA 6P, Thread 1/2 NPT</p> <p>M Aluminium T15 housing, optional display on the top, IP 66/67/NEMA 6P, M 12x1 PA plug</p> <p>N Aluminium T15 housing, optional display on the top, IP 66/67/NEMA 6P, 7/8" FF plug</p> <p>P Aluminium T15 housing, optional display on the top, IP 65/NEMA 4X, Han7D plug, 90°</p> <p>1 AISI 316L T14 housing, optional display on the side, IP 66/67/NEMA 6P, Gland M 20x1.5</p> <p>2 AISI 316L T14 housing, optional display on the side, IP 66/67/NEMA 6P, Thread G 1/2</p> <p>3 AISI 316L T14 housing, optional display on the side, IP 66/67/NEMA 6P, Thread 1/2 NPT</p> <p>4 AISI 316L T14 housing, optional display on the side, IP 66/67/NEMA 6P, M 12x1 PA plug</p> <p>5 AISI 316L T14 housing, optional display on the side, IP 66/67/NEMA 6P, 7/8" FF plug</p> <p>6 AISI 316L T14 housing, optional display on the side, IP 65/NEMA 4X, Han7D plug, 90°</p> <p>R AISI 316L T17 housing, optional display on the side, IP 66/68/NEMA 6P, Gland M 20x1.5</p> <p>S AISI 316L T17 housing, optional display on the side, IP 66/68/NEMA 6P, Thread G 1/2</p> <p>T AISI 316L T17 housing, optional display on the side, IP 66/68/NEMA 6P, Thread 1/2 NPT</p> <p>U AISI 316L T17 housing, optional display on the side, IP 66/68/NEMA 6P, M 12x1 PA plug</p> <p>V AISI 316L T17 housing, optional display on the side, IP 66/68/NEMA 6P, 7/8" FF plug</p> <p>Z Housing: see additional specifications</p>
FMD77	order code

→ For continuation of FMD77 ordering information, see the following page.

FMD77 (continued)

40					Nominal range; PN:	
					Nominal value	PN
					7D	100 mbar/10 kPa/1.5 psi
					7F	500 mbar/50 kPa/7.5 psi
					7H	3 bar/300 kPa/45 psi
				7L	16 bar/1.6 MPa/240 psi	
50					Calibration, Units:	
					1	Calibration: nominal range, mbar/bar
					2	Calibration: nominal range, kPa/MPa
					3	Calibration: nominal range, mmH ₂ O/mH ₂ O
					4	Calibration: nominal range, inH ₂ O/ftH ₂ O
					6	Calibration: nominal range, psi
					B	Custom calibration: see additional specification
				C	Factory calibration: see additional specification, Factory calibration certificate, 5-point	
				D	DKD calibration: see additional specification	
60					Membrane material (high-pressure side):	
					1	AISI 316L
					2	Alloy C
					3	Monel
					5	Tantalum
					6	AISI 316L with Gold-Rhodium coating
					7	AISI 316L with 0.09 mm PTFE foil (not for vacuum applications)
70					Process connection low-pressure side; Material; Seal:	
						Mounting: 7/16 – 20 UNF
					B	1/4 – 18 NPT IEC 61518, C22.8, FKM Viton (CRN)
					D	1/4 – 18 NPT IEC 61518, AISI 316L, FKM Viton (CRN)
					F	1/4 – 18 NPT IEC 61518, Alloy C276, FKM Viton (CRN)
					H	1/4 – 18 NPT IEC 61518, AISI 316L, PTFE+C4-ring (CRN)
					J	1/4 – 18 NPT IEC 61518, Alloy C, PTFE+C4-ring (CRN)
					K	1/4 – 18 NPT IEC 61518, AISI 316L, EPDM (CRN)
					L	1/4 – 18 NPT IEC 61518, Alloy C, EPDM (CRN)
					M	1/4 – 18 NPT IEC 61518, AISI 316L, Kalrez (CRN)
					N	1/4 – 18 NPT IEC 61518, Alloy C, Kalrez (CRN)
					P	1/4 – 18 NPT IEC 61518, AISI 316L, Chemraz (CRN)
					Q	1/4 – 18 NPT IEC 61518, Alloy C, Chemraz (CRN)
					S	1/4 – 18 NPT IEC 61518, AISI 316L, degreased (CRN)
					T	1/4 – 18 NPT IEC 61518, AISI 316L, cleaned for oxygen service (CRN)
					U	RC 1/4, AISI 316L, FKM Viton (CRN)
80					Process connection high-pressure side; Material:	
					EN/DIN flanges	
					A	DN 50 PN 10-40 B1, AISI 316L
					B	DN 80 PN 10-40 B1, AISI 316L
					C	DN 80 PN 10-40 B1, extended diaphragm seal: 50 mm/100 mm/200 mm, extended diaphragm seal: see additional specification
					F	DN 100 PN 10-16 B1, AISI 316L
					G	DN 100 PN 25-40 B1, AISI 316L
					ANSI flanges	
					N	2" 150 lbs, RF, AISI 316/316L (CRN)
					P	3" 150 lbs, RF, AISI316/ 316L (CRN)
					Q	3" 150 lbs RF, AISI 316/316L, extended diaphragm seal: 2"/4"/6"/8", extended diaphragm seal: see additional specification
					T	4" 150 lbs RF, AISI 316L (CRN)
					W	4" 300 lbs RF, AISI 316L (CRN)
					JIS flanges	
					X	10K 50A RF, AISI 316L
					1	10K 80A RF, AISI 316L
				4	10K 100 A RF, AISI 316L	
FMD77						order code

→ For continuation of FMD77 ordering information, see the following page.

FMD77 (continued)

90														Fill fluid:				
														A	Silicone oil			
																D	Vegetable oil	
																L	Low temperature oil	
																V	High-temperature oil	
																F	Inert oil	
100																Additional options 1:		
																A	Additional options 1 not selected	
																	B	Material test certificate for wetted components, inspection certificate as per EN 10204 3.1 acc. to specification 52005759
																	C	NACE MR0175 material
																	D	Material test certificate for wetted components as per EN 10204 3.1 and NACE MR0175 material, inspection certificate as per EN 10204 acc. to specification 52010806
																	M	Overvoltage protection
																	N	HistoROM module
																	2	Test report acc. to EN 10204 2.2
																	3	Routine test with certificate, inspection certificate as per EN 10204 3.1
																	4	Overpressure test with certificate, inspection certificate as per EN 10204 3.1
110																	Additional options 2:	
																	A	Additional options 2 not selected
																	M	Overvoltage protection
																	N	HistoROM module
																	R	Screws 7/16 UNF, length 1 1/2" (4 pieces)
																	2	Test report acc. to EN 10204 2.2
																	3	Routine test with certificate, inspection certificate as per EN 10204 3.1
																	4	Overpressure test with certificate, inspection certificate as per EN 10204 3.1
FMD77																		complete order code

FMD78

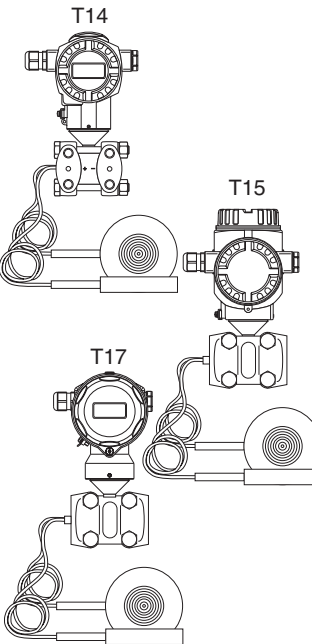
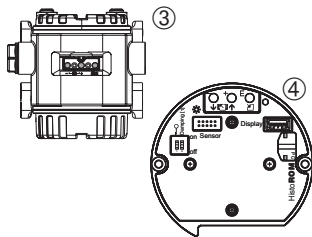
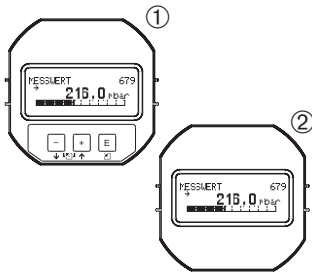

10	Approval:
	<p>A For non-hazardous areas</p> <p>1 ATEX II 1/2 G EEx ia IIC T6</p> <p>6 ATEX II 1/2 G EEx ia IIC T6, overspill protection WHG</p> <p>2 ATEX II 1/2 D</p> <p>4 ATEX II 1/3 D</p> <p>8 ATEX II 1 GD EEx ia IIC T6</p> <p>3 ATEX II 1/2 GD EEx ia IIC T6</p> <p>5 ATEX II 2 G EEx d IIC T6</p> <p>7 ATEX II 3 G EEx nA II T6</p> <p>S FM IS, Class I, II, III Division 1, Groups A – G; NI Class I Division 2, Groups A – D; AEx ia</p> <p>T FM XP, Class I Division 1, Groups A – D; AEx ia</p> <p>Q FM DIP, Class II, III Division 1, Groups E – G</p> <p>R FM NI, Class I, Division 2, Groups A – D</p> <p>U CSA IS, Class I, II, III Division 1, Groups A – G; Class I Division 2, Groups A – D, Ex ia</p> <p>V CSA XP, Class I Division 1, Groups B – D; Ex d</p> <p>W CSA Class II, III Division 1, Groups E – G (Dust-Ex)</p> <p>G NEPSI Ex d IIC T6</p> <p>H NEPSI Ex ia IIC T6</p> <p>I IECEx Zone 0/1 Ex ia IIC T6</p> <p>K TIIS Ex ia IIC T6</p> <p>L TIIS Ex d IIC T6</p> <p>B Combined certificates: ATEX II 1/2 G EEx ia IIC T6 + II G EEx d IIC T6</p> <p>C Combined certificates: FM IS and XP Class I Division 1, Groups A – D</p> <p>D Combined certificates: CSA IS and XP Class I Division 1, Groups A – D</p> <p>E Combined certificates: FM/CSA IS and XP Class I Division 1, Groups A – D</p>
20	Output; Operation:
	<p>A 4...20 mA HART, SIL operation outside, LCD (→ see Fig. ①, ③)</p> <p>B 4...20 mA HART, SIL operation inside, LCD (→ see Fig. ①, ④)</p> <p>C 4...20 mA HART, SIL operation inside (→ see Fig. ④)</p> <p>M PROFIBUS PA, operation outside, LCD (→ see Fig. ②, ③)</p> <p>N PROFIBUS PA, operation inside, LCD (→ see Fig. ②, ④)</p> <p>O PROFIBUS PA, operation inside (→ see Fig. ④)</p> <p>P FOUNDATION Fieldbus, operation outside, LCD (→ see Fig. ②, ③)</p> <p>Q FOUNDATION Fieldbus, operation inside, LCD (→ see Fig. ②, ④)</p> <p>R FOUNDATION Fieldbus, operation inside (→ see Fig. ④)</p>
30	Housing; Cable entry, Protection:
	<p>A Aluminium T14 housing, optional display on the side, IP 66/67/NEMA 6P, Gland M 20x1.5</p> <p>B Aluminium T14 housing, optional display on the side, IP 66/67/NEMA 6P, Thread G 1/2</p> <p>C Aluminium T14 housing, optional display on the side, IP 66/67/NEMA 6P, Thread 1/2 NPT</p> <p>D Aluminium T14 housing, optional display on the side, IP 66/67/NEMA 6P, M12x1 PA plug</p> <p>E Aluminium T14 housing, optional display on the side, IP 66/67/NEMA 6P, 7/8" FF plug</p> <p>F Aluminium T14 housing, optional display on the side, IP 65/NEMA 4X, Han7D plug, 90°</p> <p>J Aluminium T15 housing, optional display on the top, IP 66/67/NEMA 6P, Gland M 20x1.5</p> <p>K Aluminium T15 housing, optional display on the top, IP 66/67/NEMA 6P, Thread G 1/2</p> <p>L Aluminium T15 housing, optional display on the top, IP 66/67/NEMA 6P, Thread 1/2 NPT</p> <p>M Aluminium T15 housing, optional display on the top, IP 66/67/NEMA 6P, M 12x1 PA plug</p> <p>N Aluminium T15 housing, optional display on the top, IP 66/67/NEMA 6P, 7/8" FF plug</p> <p>P Aluminium T15 housing, optional display on the top, IP 65/NEMA 4X, Han7D plug, 90°</p> <p>1 AISI 316L T14 housing, optional display on the side, IP 66/67/NEMA 6P, Gland M 20x1.5</p> <p>2 AISI 316L T14 housing, optional display on the side, IP 66/67/NEMA 6P, Thread G 1/2</p> <p>3 AISI 316L T14 housing, optional display on the side, IP 66/67/NEMA 6P, Thread 1/2 NPT</p> <p>4 AISI 316L T14 housing, optional display on the side, IP 66/67/NEMA 6P, M 12x1 PA plug</p> <p>5 AISI 316L T14 housing, optional display on the side, IP 66/67/NEMA 6P, 7/8" FF plug</p> <p>6 AISI 316L T14 housing, optional display on the side, IP 65/NEMA 4X, Han7D plug, 90°</p> <p>R AISI 316L T17 housing, optional display on the side, IP 66/68/NEMA 6P, Gland M 20x1.5</p> <p>S AISI 316L T17 housing, optional display on the side, IP 66/68/NEMA 6P, Thread G 1/2</p> <p>T AISI 316L T17 housing, optional display on the side, IP 66/68/NEMA 6P, Thread 1/2 NPT</p> <p>U AISI 316L T17 housing, optional display on the side, IP 66/68/NEMA 6P, M 12x1 PA plug</p> <p>V AISI 316L T17 housing, optional display on the side, IP 66/68/NEMA 6P, 7/8" FF plug</p> <p>Z Housing: see additional specifications</p>
FMD78	order code

→ For continuation of FMD78 ordering information, see the following page.

FMD78 (continued)

40				Nominal range; PN:	
				Nominal value	PN
			7D	100 mbar/10 kPa/1.5 psi	160 bar/16 MPa/2400 psi
			7F	500 mbar/50 kPa/7.5 psi	160 bar/16 MPa/2400 psi
			7H	3 bar/300 kPa/45 psi	160 bar/16 MPa/2400 psi
			7L	16 bar/1,6 MPa/240 psi	160 bar/16 MPa/2400 psi
			7M	40 bar/4 MPa/600 psi	160 bar/16 MPa/2400 psi
50				Calibration, Units:	
			1	Calibration: nominal range, mbar/bar	
			2	Calibration: nominal range, kPa/MPa	
			3	Calibration: nominal range, mmH ₂ O/mH ₂ O	
			4	Calibration: nominal range, inH ₂ O/ftH ₂ O	
			6	Calibration: nominal range, psi	
			B	Custom calibration: see additional specification	
			C	Factory calibration: see additional specification, Factory calibration certificate, 5-point	
			D	DKD calibration: see additional specification, DKD-Certificate	
60				Membrane material:	
			1	AISI 316L	
			2	Alloy C	
			3	Monel	
			5	Tantalum	
			6	AISI 316L with Gold-Rhodium coating	
			7	AISI 316L with 0.09 mm PTFE foil (not for vacuum applications)	
80				Process connection, Material:	
				Membrane diaphragm seal cell structure	
			UF	Cell DN 50 PN 16-400, AISI 316L	
			UH	Cell DN 80 PN 16-400, AISI 316L	
			UJ	Cell DN 100 PN 16-400, AISI 316L	
			VF	Cell 2" 150-2500 lbs, AISI 316L	
			VH	Cell 3" 150-2500 lbs, AISI 316L	
			VJ	Cell 4" 150-2500 lbs, AISI 316L	
				Threaded connections	
			GA	Thread ISO 228 G 1/2 B, PN 40, AISI 316L, separator, PTFE seal	
			RL	Thread ANSI 1/2 MNPT, PN 40, AISI 316L, separator, PTFE seal	
				Clamp connections	
			TB	Tri-Clamp, ISO 2852 DN 25 (1"), DIN 32676 DN 25, 3 A, AISI 316L	
			TC	Tri-Clamp, ISO 2852 DN 25 – DN 38 (1 – 1 1/2"), 3 A, AISI 316L	
			TD	Tri-Clamp, ISO 2852 DN 40 – DN 51 (2")/DN 50, 3 A, AISI 316L	
			TF	Tri-Clamp, ISO 2852 DN 70 – DN 76.1 (3"), 3 A, AISI 316L	
				Pipe diaphragm seal Clamp	
			SB	Tri-Clamp, ISO 2852 DN 25 (1"), 3 A, AISI 316L	
			SC	Tri-Clamp, ISO 2852 DN 38 (1 1/2"), 3 A, AISI 316L, 3.1 + P ressure test acc. to PED Cat. II	
			SD	Tri-Clamp, ISO 2852 DN 51 (2"), 3 A, AISI 316L, 3.1 + Pressure test acc. to PED Cat. II	
				Hygienic connections	
			TR	Varivent model N for pipes DN 40 – DN 162, PN 40, 3 A, AISI 316L	
			TK	DRD 65 mm, PN 25, 3 A, AISI 316L	
			WH	Sanitary tank spud, 3 A, AISI 316L, extended diaphragm seal 2"	
			MR	DIN 11851 DN 50 PN 25, 3 A, AISI 316L	
			MS	DIN 11851 DN 65 PN 25, 3 A, AISI 316L	
			MT	DIN 11851 DN 80 PN 25, 3 A, AISI 316L	
			M3	DIN 11851 DN 50 PN 25 socket, 3 A, AISI 316L	
			M4	DIN 11851 DN 65 PN 25 socket, 3 A, AISI 316L	
			M5	DIN 11851 DN 80 PN 25 socket, 3 A, AISI 316L	
				EN/DIN flanges	
			B3	DN 50 PN 10-40 B1, AISI 316L	
			B5	DN 80 PN 10-40 B1, AISI 316L	
			BT	DN 100 PN 10-16 B1, AISI 316L	
			B6	DN 100 PN 25-40 B1, AISI 316L	
FMD78					order code

→ For continuation of FMD78 ordering information, see the following page.

FMD78 (continued)

80	Process connection, Material (continued):
	<p>ANSI flanges</p> <p>AF 2" 150 lbs RF, AISI 316/316L</p> <p>AR 2" 300 lbs RF, AISI 316/316L</p> <p>AG 3" 150 lbs RF, AISI 316/16L</p> <p>AS 3" 300 lbs RF, AISI 316/316L</p> <p>J4 3" 150 lbs RF, AISI 316/316L, extended diaphragm seal: 2"/4"/6"/8", extended diaphragm seal: see additional specification</p> <p>AH 4" 150 lbs RF, AISI 316/316L</p> <p>AT 4" 300 lbs RF, AISI 316/316L</p> <p>J5 4" 150 lbs RF, AISI 316/316L, extended diaphragm seal: 2"/4"/6"/8", extended diaphragm seal: see additional specification</p> <p>JIS flanges</p> <p>KF 10K 50A RF, AISI 316L</p> <p>KL 10K 80A RF, AISI 316L</p> <p>KH 10K 100A RF, AISI 316L</p>
90	Capillary, Fill fluid:
	<p>1 ...m capillary, silicone oil</p> <p>2 ...m capillary, vegetable oil</p> <p>3 ...m capillary, high temperature oil</p> <p>4 ...m capillary, oil for oxygen service</p> <p>5 ...m capillary, low temperature oil</p> <p>A ...ft capillary, silicone oil</p> <p>B ...ft capillary, vegetable oil</p> <p>C ...ft capillary, high temperature oil</p> <p>D ...ft capillary, oil for oxygen service</p> <p>E ...ft capillary, low temperature oil</p>
100	Additional options 1:
	<p>A Additional options 1 not selected</p> <p>B Material test certificate for wetted components, inspection certificate as per EN 10204 acc. to specification 52005759</p> <p>C NACE MR0175 material</p> <p>D Material test certificate for wetted components as per EN 10204 3.1 and NACE MR0175 material, inspection certificate as per EN 10204 acc. to specification 52010806</p> <p>M Overvoltage protection</p> <p>N HistoROM module</p> <p>S GL/ABS marine certificate</p> <p>2 Test report acc. to EN 10204 2.2</p> <p>3 Routine test with certificate, inspection certificate as per EN 10204 3.1</p> <p>4 Overpressure test with certificate, inspection certificate as per EN 10204 3.1</p>
110	Additional options 2:
	<p>A Additional options 2 not selected</p> <p>M Overvoltage protection</p> <p>N HistoROM module</p> <p>R Screws 7/16 UNF, length 1 1/2" (4 pieces)</p> <p>S GL/ABS marine certificate</p> <p>U Mounting bracket for wall and pipe, AISI 304</p> <p>2 Test report acc. to EN 10204 2.2</p> <p>3 Routine test with certificate, inspection certificate as per EN 10204 3.1</p> <p>4 Overpressure test with certificate, inspection certificate as per EN 10204 3.1</p>
FMD78	complete order code

Further documentation

Innovation

- Cerabar S/Deltabar S,
For process pressure, differential pressure, flow and level measurement: IN001P/00/en

Field of Activities

- Pressure measurement: Powerful instruments for process pressure, differential pressure, level and flow: FA004P/00/en

Technical Information

- Deltabar S: TI382P/00/en
- Deltatop/Deltaset: TI297P/00/en
- EMC test basic principles: TI241F/00/en

Operating Instructions

4...20 mA HART:

- Deltabar S: BA270P/00/en
- Description of device functions Cerabar S/Deltabar S, Pressure and Differential pressure transmitters: BA274P/00/en

PROFIBUS PA:

- Deltabar S: BA294P/00/en
- Description of device functions Cerabar S/Deltabar S, Pressure and Differential pressure transmitters: BA296P/00/en

FOUNDATION Fieldbus:

- Deltabar S: BA301P/00/en
- Description of device functions Cerabar S/Deltabar S, Pressure and Differential pressure transmitters: BA303P/00/en

Manual for Functional Safety (SIL)

- Deltabar S (4...20 mA): SD189P/00/en

Safety Instructions

Certificate/Type of Protection	Device	Electronic insert	Documentation
ATEX II 1/2 G EEx ia IIC T6	PMD70, PMD75, FMD76, FMD77, FMD78	- 4...20 mA HART, PROFIBUS PA, FOUNDATION Fieldbus	- XA235P
ATEX II 1/2 D	PMD70, PMD75, FMD77, FMD78	- 4...20 mA HART - PROFIBUS PA, FOUNDATION Fieldbus	- XA237P - XA280P
ATEX II 1/2 D EEx ia IIC T6	FMD76	- 4...20 mA HART - PROFIBUS PA, FOUNDATION Fieldbus	- XA238P - XA281P
ATEX II 1/3 D	PMD70, PMD75, FMD77, FMD78	- 4...20 mA HART - PROFIBUS PA, FOUNDATION Fieldbus	- XA239P - XA282P
ATEX II 2 G EEx d IIC T6	PMD70, PMD75, FMD77, FMD78	- 4...20 mA HART, PROFIBUS PA, FOUNDATION Fieldbus	- XA240P
ATEX II 3 G EEx nA II T6	PMD70, PMD75, FMD76, FMD77, FMD78	- 4...20 mA HART, PROFIBUS PA, FOUNDATION Fieldbus	- XA241P
ATEX II 1/2 GD EEx ia IIC T6	PMD70, PMD75, FMD76, FMD77, FMD78	- 4...20 mA HART, PROFIBUS PA, FOUNDATION Fieldbus	- XA243P
ATEX II 1 GD EEx ia IIC T6	PMD70, PMD75, FMD76, FMD77, FMD78	- 4...20 mA HART, PROFIBUS PA, FOUNDATION Fieldbus	- XA275P
ATEX II 1/2 G EEx ia IIC T6 + ATEX II 2 G EEx d IIC T6	PMD75, FMD77, FMD78	- 4...20 mA HART, PROFIBUS PA, FOUNDATION Fieldbus	- XA242P

Certificate/Type of Protection	Device	Electronic insert	Documentation
IECEx Zone 0/1 Ex ia IIC T6	PMD70, PMD75, FMD76, FMD77, FMD78	- 4...20 mA HART, PROFIBUS PA, FOUNDATION Fieldbus	- XB004P

Certificate/Type of Protection	Device	Electronic insert	Documentation
NEPSI Ex ia IIC T6	PMD70, PMD75, FMD76, FMD77, FMD78	- 4...20 mA HART, PROFIBUS PA, FOUNDATION Fieldbus	- XC004P
NEPSI Ex d IIC T6	PMD75, FMD77, FMD78	- 4...20 mA HART, PROFIBUS PA, FOUNDATION Fieldbus	- XC006P

Installation/ Control Drawings

Certificate/Type of Protection	Device	Electronic insert	Documentation
FM IS Class I, II, III, Division 1, Groups A – G; NI, Class I Division 2, Groups A – D; AEx ia	PMD70, PMD75, FMD76, FMD77, FMD78	- 4...20 mA HART - PROFIBUS PA, FOUNDATION Fieldbus	- ZD141P - ZD188P
CSA IS Class I, II, III, Division 1, Groups A – G; Class I Division 2, Groups A – G	PMD70, PMD75, FMD76, FMD77, FMD78	- 4...20 mA HART - PROFIBUS PA, FOUNDATION Fieldbus	- ZD142P - ZD189P
FM IS + XP Class I, Division 1, Groups A – D	PMD75, FMD77, FMD78	- 4...20 mA HART - PROFIBUS PA, FOUNDATION Fieldbus	- ZD186P - ZD190P
CSA IS + XP Class I, Division 1, Groups A – D	PMD75, FMD77, FMD78	- 4...20 mA HART - PROFIBUS PA, FOUNDATION Fieldbus	- ZD153P - ZD191P
FM/CSA IS + XP Class I, Division 1, Groups A – D	PMD75, FMD77, FMD78	- 4...20 mA HART - PROFIBUS PA, FOUNDATION Fieldbus	- ZD153P + ZD186P - ZD190P + ZD191P

Overspill protection

- WHG: ZE260P/00/de

International Head Quarter

Endress+Hauser
GmbH+Co. KG
Instruments International
Colmarer Str. 6
79576 Weil am Rhein
Deutschland

Tel. +49 76 21 9 75 02
Fax +49 76 21 9 75 34 5
www.endress.com
info@ii.endress.com

Endress+Hauser 

People for Process Automation