



GENERAL MONITORS

Model IR400

Infrared Point Detector for
Hydrocarbon Gas Applications



The information and technical data disclosed in this document may be used and disseminated only for the purposes and to the extent specifically authorized in writing by General Monitors.

Instruction Manual

06-14

General Monitors reserves the right to change published specifications and designs without prior notice.



**Part No.
Revision**

**MANIR400
J/06-14**



This page intentionally left blank.

Table of Contents

TABLE OF FIGURES	IV
TABLE OF TABLES	IV
QUICK-START GUIDE	2
1.0 INTRODUCTION	4
1.1 Protection for Life	4
1.2 Special Cautions and Warnings.....	4
1.3 Installation, Operation, and Maintenance	4
2.0 PRODUCT DESCRIPTION	5
3.0 INSTALLATION	7
3.1 Attaching the IR400 to a Junction Box, IR4000S, or IR4000M.....	8
3.2 Mounting Instructions.....	9
3.3 Wiring Connections.....	11
3.4 Applying Power	13
4.0 OPERATION AND CONFIGURATION	15
4.1 Zeroing, Gas Check Tests, and Calibration.....	15
4.2 IR400 Stand-alone Operation and Configuration.....	18
4.3 HazardWatch Mode	21
4.4 Gas Check Mode	21
4.5 Detector Response Time	21
5.0 MAINTENANCE	23
5.1 Developing a Maintenance Schedule	23
5.2 Gas Checks, Zeroing and Recalibration	23
5.3 Cleaning and Lubricating the IR400 and IR4000 Units.....	24
5.4 Storage.....	24
6.0 TROUBLESHOOTING	25
7.0 MODBUS INTERFACE	27
8.0 CUSTOMER SUPPORT	28
9.0 APPENDIX	29
9.1 Warranty.....	29
9.2 Principle of Operation.....	30
9.3 Specifications	31



9.4	Environmental Specifications	34
9.5	Communications	34
9.6	Engineering Documentation	35
9.7	Ordering Information	36

Table of Figures

Figure 1: IR400 with Junction Box	2
Figure 2: Wiring Diagram from IR400 to Control Equipment	3
Figure 3: Model IR400	5
Figure 4: Model IR400 with a Junction Box	8
Figure 5. IR400 Mounting Dimensions	9
Figure 6: IR400 with Junction Box	13
Figure 7: Wiring Diagram from IR400 to Control Equipment	14
Figure 8: IR400 Zero Switch / LED During Zeroing and Calibration	19
Figure 9: IR400 Optical Window Locations	24
Figure 10: Outline and Dimensional Drawing, IR400, Inch Measurements	35

Table of Tables

Table 1: Wiring Chart	2
Table 2: Wiring Chart	11
Table 3: IR400 without HART Option	17
Table 4: IR400 with HART Option	17
Table 5: GM Locations	28
Table 6: Analog Current Output	33
Table 7: Maximum Distance between IR400 and Power Source	33
Table 8: Maximum Distance between IR400 and 500-Ohm Input Impedance	33

Quick-Start Guide

Mounting and Orientation

The Model IR400 should be mounted horizontally (Figure 1) to reduce the likelihood of dirt and dust build-up on the windows. For optimum performance, the splashguards should be located on the top and bottom as shown in Figure 1. Apply the supplied thread lubricant/sealant to all conduit entries before use to prevent binding.

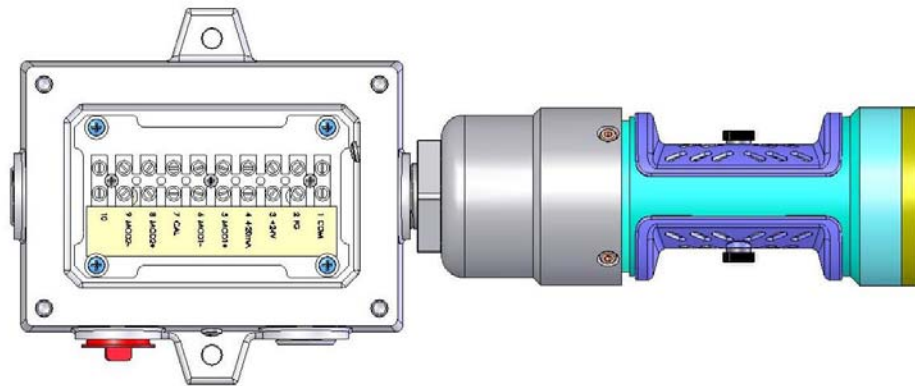

Figure 1: IR400 with Junction Box

Wiring Connections

TERMINAL	WIRE COLOR	SIGNAL
1	BLACK	COM
2	GREEN	FIELD GROUND (FG)
3	RED	+24 V
4	WHITE	4-20 mA
5	BLUE	MOD1+
6	WHT/BLU	MOD1 -
7	BROWN	CAL
8	-	MOD2+ (no connection for IR400)
9	-	MOD2 - (no connection for IR400)
10	-	No Connection

Table 1: Wiring Chart

NOTE: Power should remain disconnected until all other wiring connections are made.

Power Connections

To supply power to the IR400, connect the red lead from the IR400 to the +24 VDC terminal on the power supply. Connect the black lead from the IR400 to the power supply Common. Refer to the manual of the power source being used, for more detailed instructions.

NOTE: If the Model IR400 is being used with a +24 VDC power supply and an industrial analog to digital (A/D) converter, then the negative supply (Common) of all three must be connected.

Applying Power

Before applying power to the system for the first time, all wiring connections should be checked for correctness. Upon initial power-up or after a fault condition has been corrected, the unit will enter a start-up mode for 2 minutes before normal operation. IR400 Ethylene start-up can take up to 10 minutes. As a unit warms up, output may briefly be negative.

After power is applied, the IR400 should be allowed to stabilize for approximately 60 minutes while the unit attains the proper operating temperature. After stabilization, it is recommended that the IR400 be zeroed, per the procedure in section 4.1 (step 1 only). A gas check should then be performed to ensure that the unit is operating properly. Use the General Monitors Gas Check Kit (P/N 32548) to perform this check.

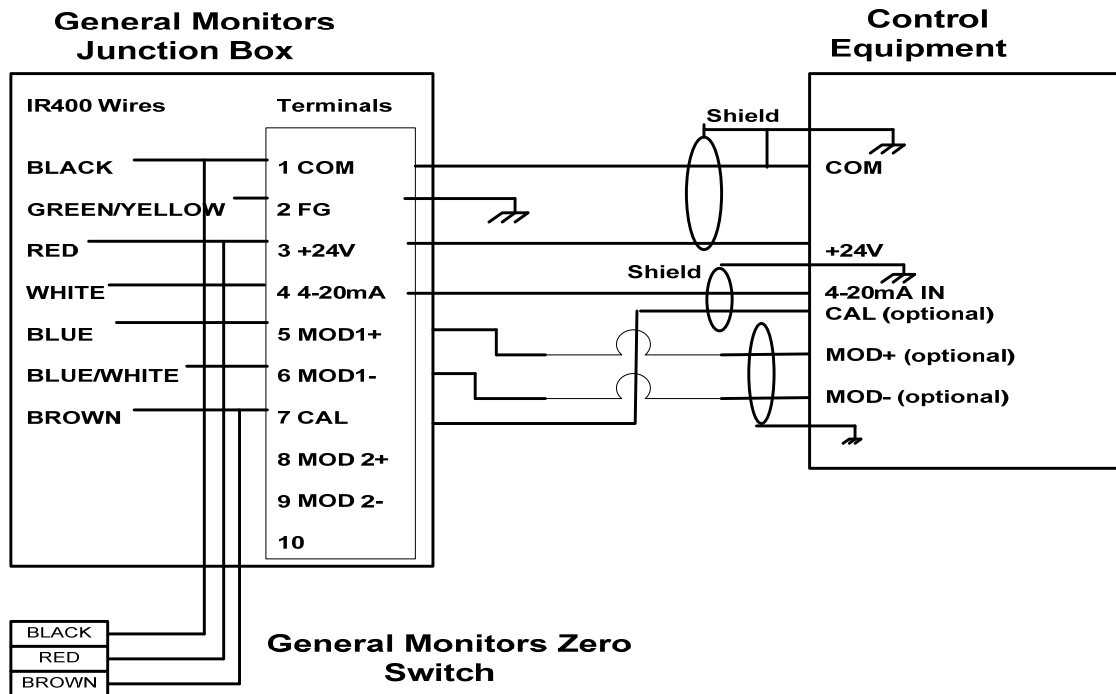

Figure 2: Wiring Diagram from IR400 to Control Equipment

The instrument is now ready to operate. Please further consult this manual for more information on the instrument's many features.

1.0 Introduction

1.1 Protection for Life

General Monitors' mission is to benefit society by providing solutions through industry-leading safety products, services and systems that save lives and protect capital resources from the dangers of hazardous flames, gases and vapors.

The safety products you have purchased should be handled carefully and installed, calibrated and maintained in accordance with this instruction manual. Remember, these products are for your safety.

1.2 Special Cautions and Warnings

This instruction manual includes numerous cautions and warnings that are included to prevent injury to personnel and prevent damage to equipment.



WARNING: TOXIC, COMBUSTIBLE, AND FLAMMABLE GASES AND VAPORS ARE VERY DANGEROUS. USE EXTREME CAUTION WHEN THESE HAZARDS ARE PRESENT.

1.3 Installation, Operation, and Maintenance

Before power up, verify wiring, terminal connections and stability of mounting for all integral safety equipment.

Proper system operation should be verified by performing a full, functional test of all component devices of the safety system, ensuring that the proper levels of alarming occur. Fault/malfunction circuit operation should be verified.

Periodic testing/calibrating should be performed per the manufacturer's recommendations and instructions.

When testing produces results outside of the manufacturer's specifications, re-calibration or repair/replacement of the suspect device(s) should be performed as necessary. Calibration intervals should be independently established through a documented procedure, including a calibration log maintained by plant personnel, or third party testing services.

2.0 Product Description

General Description

The Model IR400 infrared (IR) point detector is a microprocessor-based combustible gas detector, is calibrated at the factory and needs no routine field calibration. Applying a test gas to the unit can check the sensitivity of the IR400. It is also relatively maintenance free, requiring only a periodic cleaning of the windows and re-zeroing to ensure dependable performance.

The IR400 continuously monitors combustible gases in the lower explosive limit (LEL) range and provides a 4 to 20 mA analog signal proportional to the 0 to 100% LEL concentration. Gas calibration is available to LEL values defined by ISO 10156/NFPA 325 and IEC 60079-20. A Modbus communications interface is also provided for informational / programming purposes. Sensor data and status information from the IR400 can be transmitted to a variety of General Monitors' readout units.

The IR400 operates from an +24 volt DC supply.



Figure 3: Model IR400

Features and Benefits

This is a partial list of features and benefits for the Model IR400 infrared point detector:

- No routine calibration required
- Fail-to-safe operation
- T90 response time ≤ 3 seconds
- 4-20 mA output
- Modbus communications link
- Optional HART interface
- Heated optics eliminate condensation
- Dirty optics indication
- Reading not affected by air velocity
- Immune to typical poisons (e.g. silicones, halides, lead, sulfur)
- Works in oxygen deficient environments
- Able to operate in constant hydrocarbon environment without adverse effects
- IP66 & Type 4X rated enclosure
- Interfaces directly with the DC110 controller & TA102A trip amplifier
- Expanded capabilities when used with IR4000S Single and IR4000M Multi-Point monitors

3.0 Installation

Receipt of Equipment

All equipment shipped by General Monitors is packaged in shock absorbing containers, which provide considerable protection against physical damage. The contents should be carefully removed and checked against the packing list. If any damage has occurred or there is any discrepancy in the order, please notify General Monitors as soon as possible. All subsequent correspondence with General Monitors must specify the equipment part number and the serial number.

Detector Location Considerations

There are no standard rules for detector placement, since the optimum detector location varies with the application. The customer must evaluate conditions at the facility to make this determination. If practical, the Model IR400 infrared point detector should be easily accessible for occasional integrity checks. The unit should be mounted horizontally so that dirt and dust do not build-up on the windows. Although the IR400 is EMI/RFI resistant, it should not be mounted close to radio transmitters, high magnetic or electrical fields or similar equipment. Proper wiring and grounding is essential for optimum performance. Snap-on ferrite filters can provide additional resistance to electromagnetic and radio frequency interference.

NOTE: The Model IR400 cannot detect hydrogen (H₂) gas.

Some other factors to consider when selecting a detector location:

- Emission temperature and vapor density of the gas. The IR400 should be located near the floor for gas vapors that are heavier than air.
- Do not locate the IR400 in areas that exceed the maximum operating temperature of the unit, such as gas turbine exhaust.
- Locate the IR400 where prevailing air currents contain the maximum concentration of gas.
- Locate the IR400 as near as possible to the likely source of a gas leak.
- Observe the temperature range of the IR400 and locate the unit away from concentrated sources of heat or light.
- Mount the IR400 away from sources of excessive vibration.



WARNING: Each IR400 is completely tested at the factory. However, a complete system checkout is required upon initial installation and start-up to ensure system integrity.

NOTE: The Model IR400 is factory calibrated and needs no routine calibration. However, if the IR400 is to be installed at altitudes greater than 1000 ft (300m), it must be re-calibrated on-site (Section 4.1).

3.1 Attaching the IR400 to a Junction Box, IR4000S, or IR4000M

Before you can mount an IR400 device, you must first attach it to an IR400 junction box, IR4000S single point monitor, or an IR4000M multi-point monitor.



CAUTION: To prevent damage by static electricity, avoid contact with PCB components. All wire connections should be made to the terminal blocks.

To Attach an IR400 to a Junction Box, IR4000M, or IR4000S

1. Apply the supplied thread lubricant/sealant to all conduit entries of the IR400, junction box, IR4000M, or IR4000S, as needed to prevent binding.

Remove the cover from the junction box, IR4000M, or IR4000S by loosening the four captive screws with a 5 mm Allen wrench, and lifting the cover straight up.

Strip and trim the wires from the IR400 as needed and thread them into either the right or left wiring conduit of the junction box, IR4000M, or IR4000S.

Once the wires are threaded into the enclosure, screw the IR400 securely into the junction box, IR4000M, or IR4000S. An example is shown below.

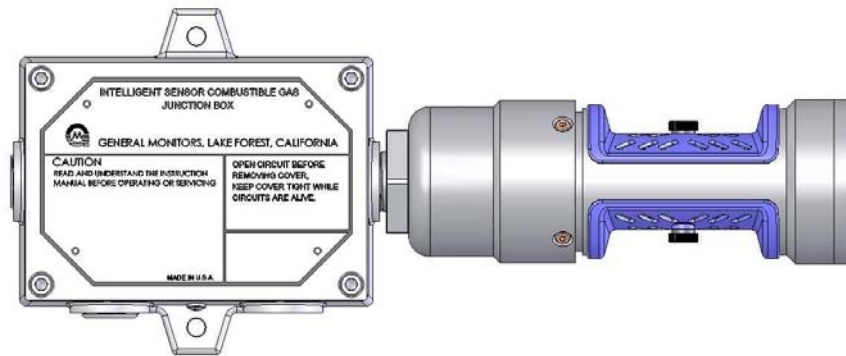

Figure 4: Model IR400 with a Junction Box

Fasten the IR400 wires to a wiring connector inside the junction box, IR4000M or IR4000S enclosure. Once the two units are attached, you may replace the cover on the enclosure attached to the IR400 using the four captive screws, or leave it off until additional cabling from the enclosure is completed.

3.2 Mounting Instructions

The IR400 is mounted using the bolt holes on an attached junction box, IR4000M or IR4000S enclosure. The IR4000M(S) is often mounted remote from the IR400 units, in order to locate it within easy reach and at eye level.

3.2.1 Mounting an IR400 with an Attached Enclosure

The following figure shows the overall and mounting dimensions for the Model IR400 with an attached junction box / IR4000M(S) enclosure.

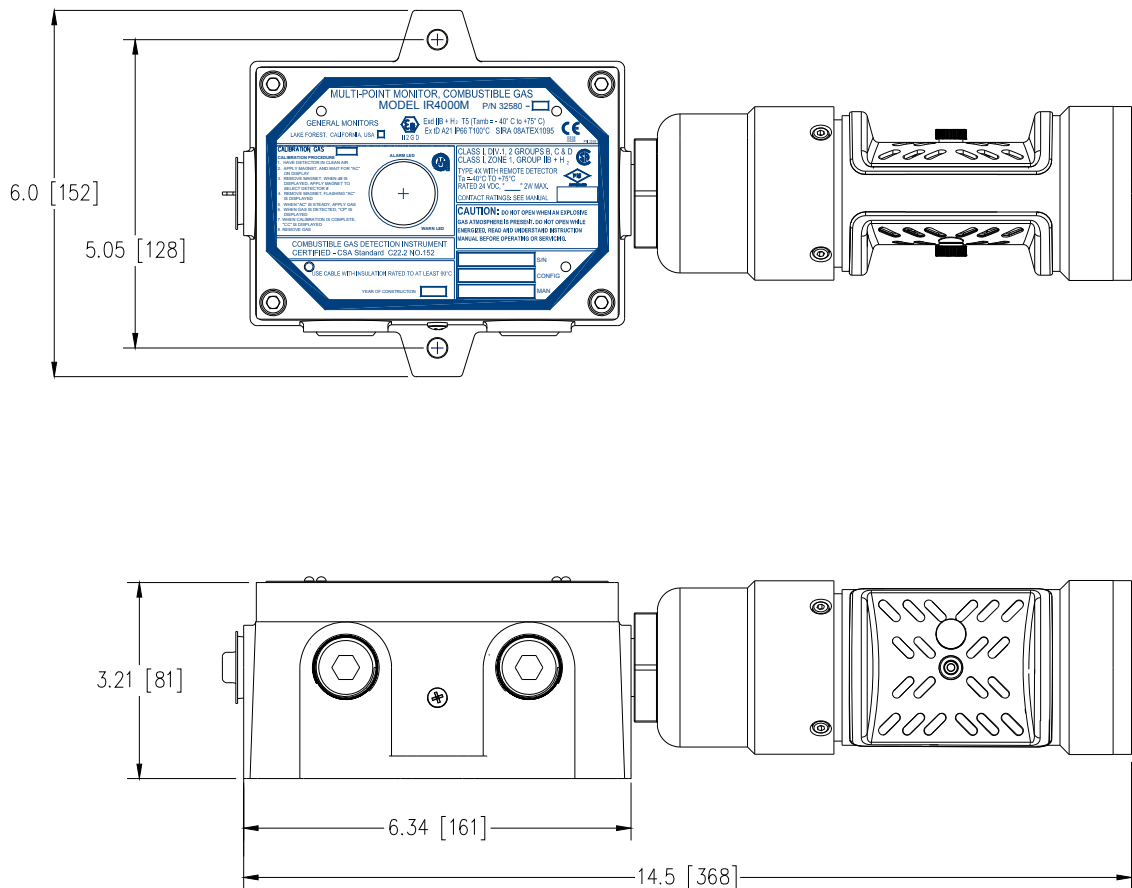

Figure 5. IR400 Mounting Dimensions

To Mount the IR400

The IR400 must rest horizontally to reduce the possibility of dirt and dust building up on the lens.

- The open slots of the gas passage must be straight up and down for the gas to rise up and through the unit.
- If the detector is installed with the metal section blocking the gas flow, it will slow down the detector's response.

Mount the attached junction box or IR4000M(S) enclosure using the two bolt holes.

3.2.2 Cabling Safety Notices



CAUTION: The Model IR400 detector and Model IR4000M(S) monitor system contain components that can be damaged by static electricity. Special care must be taken when wiring the system to ensure that only the connection points are touched.



WARNING: Under **NO** circumstances should equipment be connected or disconnected when under power. This is contrary to hazardous area regulations and may also lead to serious damage to the equipment. Equipment damaged in this manner is not covered under warranty.

3.2.2.1 European Union (EU) Approved Cable Armor and Screens

Interconnecting cables must have an overall screen or screen and armor. BS5308 cables are suitable. Note that the terms 'screen' and 'shield' are equivalent for the purpose of this manual. The cable armor must be terminated in a suitable cable gland at the detector to ensure a positive electrical connection.

3.2.2.2 Cable Termination in Non-Hazardous Areas

- The cable **armor** must be connected to **safety earth** in the safe area.
- The cable screen (drain wire) must be connected to an instrument earth in the safe area.
- The power supply 0V return must be connected to an instrument earth in the safe area.
- The interconnecting cables should be segregated from power and other noisy cables. Avoid proximity to cables associated with radio transmitters, welders, switch mode power supplies, inverters, battery chargers, ignition systems, generators, switch gear, arc lights and other high frequency or high power switching process equipment.
- In general, maintain separation of at least 1 meter between instrument and other cables. Greater separations are required where long parallel cable runs are unavoidable. Avoid running instrument cable trenches close to lightning conductor earthing pits.
- Complete all cable insulation testing before connecting the cable at either end.

3.2.3 Conduit Entries

Please keep the following warnings and cautions in mind when you install the IR400 and IR4000 units. Information on Class I Division 1 wiring methods can be found in NEC Article 501.10.



WARNING: Unused cable entry holes in each IR400 junction box and IR4000M(S) must be sealed with approved explosion-proof stopping plugs. Red caps supplied by General Monitors are for dust protection only, and must not be left on the unit when installed.



CAUTION: Acetic acid will cause damage to metal components, metal hardware, ceramic ICs, etc. If damage results from the use of a sealant that contains acetic acid (RTV silicone), the warranty will be void.



CAUTION: To prevent corrosion due to moisture or condensation, it is recommended that the conduit connected to the display unit housing contain a drain loop.

3.3 Wiring Connections

WIRE	WIRE COLOR	SIGNAL
1	BLACK	COM
2	GREEN	FIELD GROUND (FG)
3	RED	+24 V
4	WHITE	4-20 mA
5	BLUE	MOD1+
6	WHT/BLU	MOD1-
7	BROWN	CAL
8	-	MOD2+ (no connection for IR400)
9	-	MOD2 - (no connection for IR400)
10	-	No Connection

Table 2: Wiring Chart

The IR400 operates on nominal power of +24 VDC. The customer must provide primary DC voltage power, unless a General Monitors readout/relay display module with an internal power supply is used. Since the IR400 is designed to continuously monitor for leaks of hydrocarbon gas, a power switch is not included to prevent accidental system shut down.

NOTE: Power should remain disconnected until all other wiring connections are made.

The maximum distance between the IR400 and the power source is specified in Section 9.3.3.

3.3.1 Power Connections

To supply power to the Model IR400 connect the red lead from the IR400 to the +24 VDC terminal on the power supply. Connect the black lead from the IR400 to the power supply Common. Refer to the manual of the power source being used, for more detailed instructions.

NOTE: If the IR400 is being used with a +24 VDC power supply and an industrial analog to digital (A/D) converter, then the negative supply (Common) of all three must be connected.

An internal diode protects the system in the event of inadvertent supply reversal.

3.3.2 4- 20 mA Output

A 4 to 20 mA output signal is provided by the Model IR400 and can be sent to a General Monitors' readout/relay display module or any industrial device that can accept a 4 to 20 mA signal for computer based multi-point monitoring. The Analog Output connection provides a signal for use in displaying current LEL readings, special operation or fault conditions. The maximum distance between the IR400 and the device connected to the Analog Output signal is specified in Section 9.3.5.

To access the 4-20 mA signal, connect the white lead from the IR400 to the signal-in terminal of the input unit. Refer to the manual of the display or other device being used for detailed instructions.

Connect the black lead from the IR400 to the device Common. The Common connection serves both the analog signal and the power connections.

3.3.3 Dual Modbus Interface

To access the Modbus (Modbus-RTU) interface, connect the blue lead from the IR400 to the Modbus (+) terminal and the blue/white lead to the Modbus (-) terminal on the customer's Modbus capable device. For a description of the data available from the IR400 and the programming interface, please refer to the separate IR400 Modbus manual.

3.3.4 HART Interface

A standard HART interface is available which provides a digital data channel at 1200 baud over the 4-20 mA current loop. See the IR400 HART Manual Addendum for additional information.

3.3.5 Magnetic Switch

The IR400 also provides a lead for connecting a +24 VDC powered magnetic switch. The brown lead from the IR400 must be connected to the powered side of the switch so that when the switch is activated, the brown lead is grounded. General Monitors can supply a junction box with an integral magnetic switch to ease the connection of the IR400 in the field (Figure 6).

3.4 Applying Power

Before applying power to the system for the first time, all wiring connections should be checked for correctness. Upon initial power-up or after a fault condition has been corrected, the unit will enter a start-up mode for 2 minutes before normal operation. IR400 Ethylene start-up can take up to 10 minutes. As a unit warms up, output may briefly be negative.

After power is applied, the IR400 should be allowed to stabilize for approximately 60 minutes while the unit attains the proper operating temperature. After stabilization, it is recommended that the IR400 be zeroed, per the procedure in Section 4.1 (step 1 only). A gas check should then be performed to ensure that the unit is operating properly. Use the General Monitors gas check kit (P/N 32548-x) to perform this check. If the unit does not respond properly, calibrate per the procedure in Section 4.2.3 (steps 1-4).

- When connecting the IR400 to a safety system, the +24 VDC (red) wire should be the last wire connected and first wire disconnected when removing the unit to protect the system from shorting.
- If the analog (4-20 mA) output is not used, then the white signal wire must be connected to ground to prevent a fault condition.

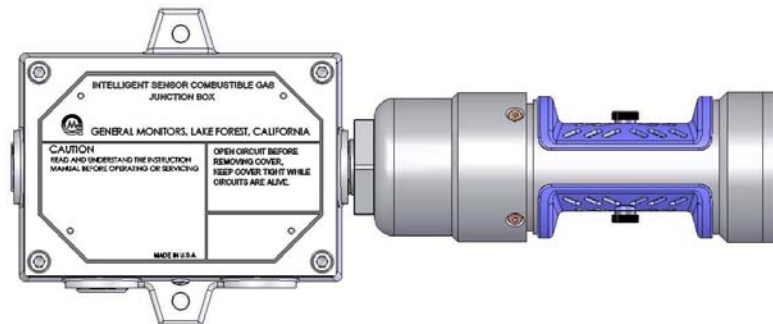

Figure 6: IR400 with Junction Box

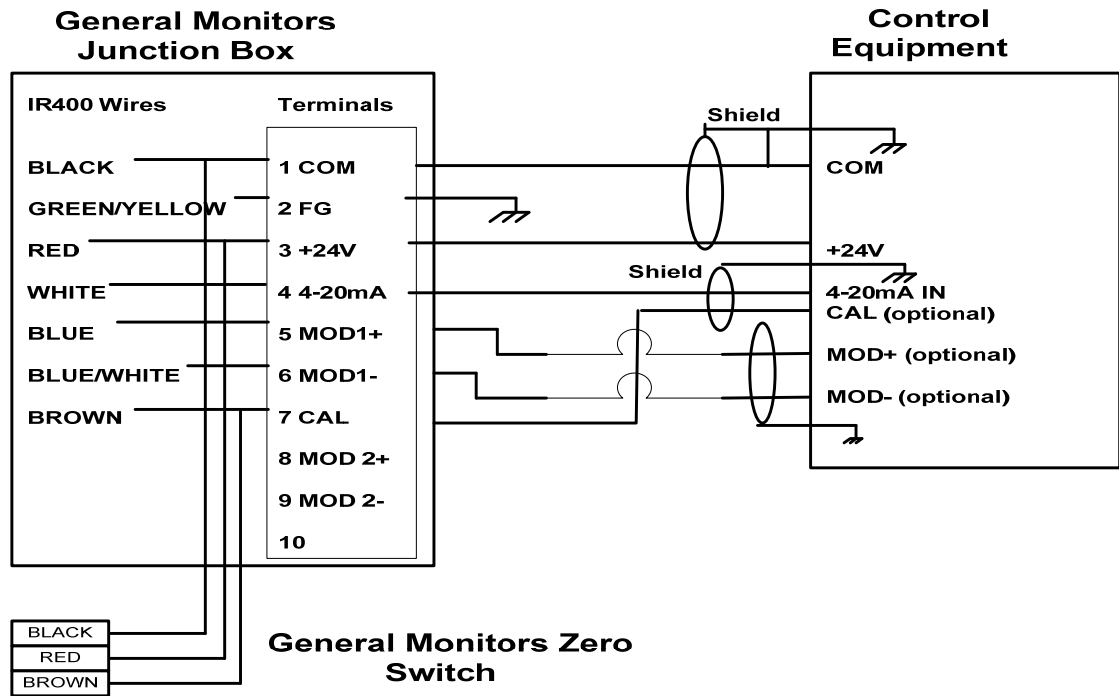

Figure 7: Wiring Diagram from IR400 to Control Equipment

4.0 Operation and Configuration

The methods used to operate and configure the IR400 will vary depending on whether you are using the IR400 as part of an IR4000M monitoring system, or as a stand-alone unit attached to a junction box and control room devices, or to an IR4000S. Separate instructions are provided in this chapter for each situation.

- *If your IR400 is part of an IR4000M system, you can operate and configure both the IR400 and the IR4000 using the IR4000 menu options and LED display. You can also send Modbus or HART commands to the IR4000 from connected control room devices, to perform all the menu-driven functions, plus additional ones.*
- *If your IR400 is a stand-alone unit attached to a junction box, you can use the magnetic switch attached to the junction box for zeroing and calibration. You can also send Modbus or HART commands to the IR400 from control room devices to perform zero, calibration, gas checks and configuration tasks.*
- *If your IR400 is a stand-alone unit attached to an IR4000S display device, then you can use the IR4000S menus for operation and configuration.*

NOTE: This chapter describes how to use the junction box magnetic switch for stand-alone IR400 operation; the IR4000 manual describes how to use the IR4000 menus for IR400 system operation and configuration.

4.1 Zeroing, Gas Check Tests, and Calibration

Each IR400 is calibrated at the factory. However they will need occasional zeroing as well as gas check tests after initial installation to make sure they are working properly. Before zeroing or calibration, always check that the optics path is clear and the windows are clean. These are the most important operations to ensure that the IR400 is measuring accurately.

Depending on your system configuration, you can use menus, Modbus/HART commands or magnetic switch selection to initiate zeroing, gas checks and calibration, as described later in this chapter. Some general guidelines are provided here that are useful no matter what method is used.

NOTE: The IR400 is factory calibrated and needs no initial calibration. However, if the unit is to be installed at altitudes greater than 1000 ft (308 m), it must be re-calibrated on-site.

NOTE: Entering Gas Check, Zeroing, or Calibration mode sends a 1.5 mA output signal that disables the IR4000M and IR4000S Warning and Alarm relay circuits.

4.1.1 Using Zero Air

If you suspect that combustible gasses are present, it is necessary to purge the sensor environment with zero air before zeroing the unit, starting the gas check, or starting calibration.

4.1.2 Zeroing Guidelines

Zeroing the IR400 detector is necessary periodically in order to eliminate any background gas fluctuations. You may wish to purge the sensor environment with zero air before zeroing the unit.

4.1.3 Gas Check Test Guidelines

Running a gas check test enables you to verify whether the detector is functioning correctly, by applying a known gas concentration and monitoring the % LEL reading while keeping the alarm and warning relays disabled. To apply gas or a gas simulation during the test, you can use the General Monitors gas check kit with portable purge calibrator equipment.

CAUTION – The FMD and IR4000S turn off the Warn and Alarm relays during Gas Check, but the current loop from the IR400 will still transmit the gas concentration level. Make sure that any equipment monitoring the analog output is in alarm bypass mode before performing a gas check with the FMD or IR4000S.

4.1.3.1 Portable Purge Calibrator Equipment



The portable purge calibrator is a compact, accurate and safe system containing a non-explosive gas concentration. The lecture bottle is filled with a standard 50% LEL mixture of gas/air. Using a known gas/air mixture reduces the likelihood of error in field calibration.

The hose and cup adapter that are included allow for quick calibrations and gas checks. Pre-mixed calibration gases at approximately 50% LEL are available in lecture bottles.

- Butane_{C₄H₁₀}
- Ethylene_{C₂H₄}
- Methane_{C_H4}
- Propane_{C₃H₈}
- Ethane_{C₂H₆}
- Hexane_{C₆H₁₄}
- Pentane_{C₅H₁₂}

Spare bottles containing these gases may be ordered. Methane lecture bottles may be returned

to General Monitors for refilling with the standard 2.5% by volume methane (50% LEL per ISO 10156 and NFPA 325).

4.1.4 Calibration Guidelines

Calibrating the detector corrects any errors that may be affecting the % LEL measurement that is taking place. You should use the General Monitors gas check kit for calibration. Section 4.1.3.1 describes the gas check kit equipment in more detail. You may need to calibrate the IR400 detector under several circumstances.

- If the gas check test indicates that the detector needs adjustment.
- If you are reconfiguring the IR400 to detect a different type of gas.
- If you are moving the detector to a higher altitude location (every 1000 feet difference in altitude requires recalibration).

General Monitors configures the IR400 with three calibration input options: magnetic switch (default), manual solenoid, and automatic remote gas calibration device (ARGC). To use the manual solenoid or ARGC, purchase a factory configured IR400 or change the calibration input via Modbus or HART.

4.1.5 IR400 Analog Output (AO) Interpretation

Current Level (mA)	Meaning
0	Startup mode and critical fault for non HART unit
1.5	Zero, Calibration and Gas Check Mode
2	Non critical fault
4 – 20	0 – 100% LEL or % by Volume
20.1 – 21.7	Over range

Table 3: IR400 without HART Option

Current Level (mA)	Meaning
0	Startup mode and critical fault for non HART unit
1.25	Startup mode and critical fault if current range is low
1.5	Zero, Calibration and Gas Check Mode
2	Non critical fault
3.5	All faults and startup if unit is configured with current range set to “high”
4 – 20	0 – 100% LEL or % by volume
20.1 – 21.7	Over range

Table 4: IR400 with HART Option

4.1.6 IR400 Zero Switch / LED flashing patterns

Flashing Pattern (ms)	Description
1000 on, 1000 off	Zero
950 on, 50 off	Zero complete, calibration pending
100 on, 400 off	Calibration, apply gas
500 on, 1000 off	Gas present, calibration in progress
980 on, 20 off	Calibration complete; remove gas
100 on, 100 off	Fault

NOTE: This table is for Zero Switch / LED calibration input configurations only.

4.2 IR400 Stand-alone Operation and Configuration

The IR400 does not have built-in operation and configuration menus without an IR4000. However, zeroing and calibration can be accomplished using the Zero (magnetic) Switch / LED on the junction box that is directly attached to the IR400. You should 'zero' the Model IR400 detectors occasionally to eliminate any background gas fluctuations. Calibration is necessary if gas check readings show the unit is reading inaccurately.

In addition, many operational functions are available using the Modbus/HART interface from a control room device, as described in separate General Monitors' manuals (available from our website).

4.2.1 To Zero and Calibrate a Stand-alone IR400 Using a Magnetic Switch

This procedure describes how to use the IR400 junction box magnetic switch to zero and calibrate the IR400. Once zeroing or calibration begins, the alarm and warning relays are automatically kept disabled, and the analog signal is held at 1.5 mA. As you follow the procedure steps, refer to the figure shown below for the LED indicator.

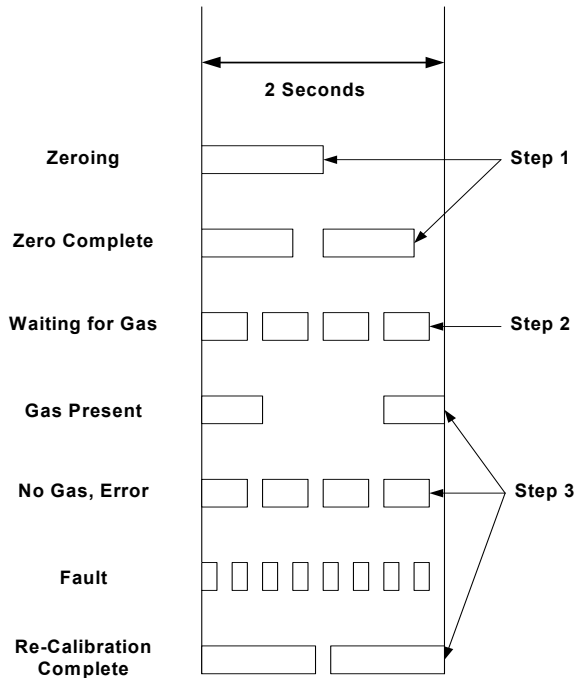

Figure 8: IR400 Zero Switch / LED During Zeroing and Calibration

Review the general guidelines in Section 4.1 on Zeroing, Gas Check Tests, and Calibration. Make sure the windows are clean and there is nothing blocking the optical beam.

4.2.2 Zero Only Calibration

The junction box used with the IR400 is fitted with a zero switch which eliminates any background gas fluctuation.



Zero the Unit. Apply the General Monitors magnet that was included with the unit to the Zero Switch / LED for approximately three seconds. The LED in the switch will light to show proper placement.

- Remove the magnet and the LED will flash on for one second and off for one second to indicate that the unit is attaining a zero value (*Zeroing* in the figure).
- When the unit has finished zeroing, the LED will turn on and flash off quickly once per second for 30 seconds (*Zero Complete* in Figure 8).

NOTE: If an error occurs during the zeroing/calibration sequence, the LED will flash on and off rapidly (*Fault*).

4.2.3 Full Span Calibration

If a full span calibration is required, a zero calibration must first be performed to eliminate any background gas fluctuation. When the zero calibration is complete, a full span calibration may optionally be performed.

1. **Zero the Unit.** Apply the General Monitors magnet that was included with the unit to the Zero Switch / LED for approximately three seconds. The LED in the switch will light to show proper placement.
 - Remove the magnet and the LED will flash on for one second and off for one second to indicate that the unit is attaining a zero value (*Zeroing* in the figure).
 - When the unit has finished zeroing, the LED will turn on and flash off quickly once per second for 30 seconds (*Zero Complete* in Figure 8).

NOTE: If an error occurs during the zeroing/calibration sequence, the LED will flash on and off rapidly (*Fault*).

2. **Return to Normal Operation or Start Calibration.** If the magnet is not applied again, the unit will return to normal operation. To continue on and calibrate, apply the magnet again and the unit will enter the calibration mode.

The LED will flash off quickly once every half-second while the unit is waiting for gas to be applied (*Waiting for Gas*).

3. **Apply Gas.** Apply a 50% LEL gas using a Gas Check Kit with portable purge calibrator equipment (or 50% by volume of the gas being detected in nitrogen for units designed for monitoring 0 to 100% by volume).
 - When the unit detects the gas, the LED will flash on for a half second every one and one-half seconds (*Gas Present*).
 - If the unit does not detect the gas, the LED will flash off quickly once every half-second while the unit is still waiting for gas to be applied (*No Gas Error*).
 - Once calibration has been completed, the LED will turn on and flash off once every second (*Calibration Complete*).
4. **Return to Normal Operation.** Remove the gas and the unit will return to normal operation once the gas has fallen below 5% of full scale.

4.3 HazardWatch Mode

The IR400 is compatible with the General Monitors HazardWatch System and can be calibrated via the system interface for HazardWatch. To support calibrations initiated in HazardWatch, the IR400 must be configured in the HazardWatch Mode. This mode prevents aborted calibrations from being recorded as successful calibrations and ensures accurate logging in the HazardWatch System.

To use this feature, purchase a HazardWatch-configured IR400 or change the mode via Modbus. See the Modbus manual available from the General Monitors website for Modbus commands.

4.4 Gas Check Mode

1. Send Modbus or HART gas check command.
2. When the unit enters gas check mode, AO will be kept at 1.5 mA. Apply a 50% LEL gas using a gas check kit with portable purge calibrator equipment.

NOTE: If the manual solenoid calibration input is configured, send the Modbus or HART command to turn on the solenoid.

3. Once the detector is placed in gas check mode and the gas is applied, monitor the % LEL reading for the detector to see if it is functioning properly using the FMD or IR4000S display or Modbus/HART commands. When the reading is stabilized, it should be 50% LEL if the gas from the check kit is applied.
4. Remove the gas.

NOTE: If the manual solenoid calibration input is configured, send the Modbus or HART command to turn off the solenoid.

The unit will return to normal operation when the concentration drops below 5% full-scale. Since the IR400 zeros before calibrating, you must remove the gas completely before going to calibration mode.

4.5 Detector Response Time

A valid response time of a gas detector must take into account a static gas presence as it occurs in the field with a gas leak. Tests performed on site use a flow method to verify detector function only as gas enters the optical path, with its splashguard in place, slowly. With regard to the specified response times, these specifications were obtained by testing the gas detector, with a splashguard, in accordance with agency performance requirements. A chamber is filled with a known concentration of gas (static) and the IR400 is then exposed to the gas. This method is defined by the approval agencies and allows us to fill instantaneously the optical path of detector to achieve the stated response times for the IR400. It is not practical to perform this type of test in the field since a potentially explosive gas (100% LEL) is used.

T response times: According to CSA C22.2, T50 equals time to 50% of full-scale meaning 50% LEL and T90 which is 90% of the final reading.

CSA Standard C22.2 No. 152 Combustible Gas Detection Instruments, Section 6.9 states:

Beginning with the gas sensing element in clean air it shall be suddenly exposed to a prepared mixture of gas in air having a concentration corresponding to 100% of the full scale gas concentration. From the instant of exposure to this gas mixture the instrument shall respond to provide an indication within the time specified as follows: 50% of full scale gas concentration in 10 sec, and 90% of maximum indicated gas concentration in 30 sec.

The products offered by GM are not for the purpose of testing response time, but as a method to allow a user to check that the unit is responding to gas and/or that final response is within tolerance. If it's required to demonstrate a reading of 50% LEL at site this can be achieved using the calibration cup, however it should be noted that you need to apply the test gas for approximately three minutes to get a reading of 50% LEL. This time is due to the ambient air located in the optical path of the detector having to be replaced progressively by the test gas. This replacement of ambient air is quicker at the beginning but longer for the last percentage because it is linked to the slow replacement of air dilution by the test gas. This test is only to indicate a gas level of 50% LEL within the calibration cup and is not a reflection of the response time of the detector.

5.0 Maintenance

The Model IR400 is calibrated at the factory and is fail-to-safe; once it is correctly installed and calibrated upon start-up, it requires little maintenance other than periodic cleaning, gas checks, zeroing and recalibration to ensure system integrity. Integrity checks can be performed using General Monitors' Gas Check Kit (P/N 32548).



WARNING: Disconnect or inhibit external devices such as Trip Amplifiers, PLC's, or DCS systems before performing any maintenance.

NOTE: If an optical fault still occurs after cleaning and re-zeroing of an IR400 detector is complete, then you must return the unit to the factory for service. The system's full two-year warranty will be voided if customer personnel or third parties damage the system during repair attempts or maintenance activities. Gassing into the screened splashguard will not provide a stable or accurate reading.

5.1 Developing a Maintenance Schedule

Maintenance requirements will vary with each installation; General Monitors recommends that a schedule for periodic maintenance be established and followed, and that a maintenance logbook be kept for each unit in operation.

More frequent cleaning and calibration checks are recommended if the equipment is impacted by unusual environmental conditions such as mud collecting on the sensor head, sensors accidentally being painted over, etc.

General Monitors is not implying that the customer should expect problems with sensor life or stability, but calibration checks ensure the integrity of the life protecting equipment.

5.2 Gas Checks, Zeroing and Recalibration

The Model IR400 is calibrated at the factory and needs only occasional recalibration after initial installation and start-up.

- For detailed instructions on initiating gas checks, zeroing and calibration using the IR4000 menus, see the user manual for the IR4000.
- For instructions on zeroing and recalibrating a stand-alone IR400 using the magnetic switch on an attached junction box, see Section 4.2.1.
- For information on the Modbus IR400 and IR4000 register *Operating Mode* commands for gas checks, zeroing and calibration, refer to the separate Modbus manuals.

5.3 Cleaning and Lubricating the IR400 and IR4000 Units

5.3.1 Cleaning the IR400 and IR4000 Units

The IR400 optical windows can be cleaned by removing the splashguard that covers them, then gently wiping them with a soft, clean cloth or cotton swab that has had a commercial window cleaning solution applied; water or ethanol are examples of suitable solvents. You can remove particulate matter from the IR400, detector accessories, and IR4000 units using an appropriate halogen-free solvent, such as water or ethanol. Accessories should be thoroughly dried with compressed air, if necessary, before refitting them to the detector.

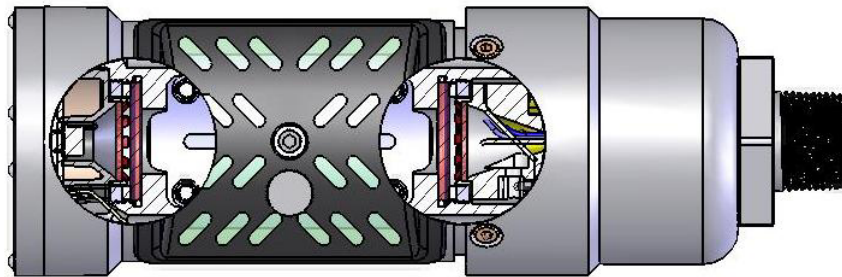

Figure 9: IR400 Optical Window Locations

NOTE: Do not clean the windows while an IR400 unit is zeroing or in recalibration mode. The unit must be re-zeroed after cleaning.

5.3.2 Lubricating IR400 and IR4000 Units

If the neoprene rubber gasket (O-ring) in the cover of the IR4000 enclosure is found dry, it should also be lubricated with the lubricant/sealant that is included with the IR400/IR4000 units, or is available on order from General Monitors (P/N 916-062).

As an alternative to grease, PTFE (Teflon) tape may be used.

5.4 Storage

The Model IR400 Gas Detector and IR4000 Monitor System should be stored in a clean, dry area, and within the temperature and humidity ranges noted for environmental specifications in Section 9.3.3 Electrical Specifications for the IR400, and the separate user manual for the IR4000. Insert the red dust caps into any vacant cable entry holes while the unit is stored.

6.0 Troubleshooting

The IR400 will alert the operator that there are problems in a number of ways. The table on the following page shows the value for the analog output, the value read through Modbus register 2 (if Modbus is being used), and the fault code, shown as F and a number, on the IR4000 display (if connected).

If the IR400 is connected to a zero switch, then the LED in the zero switch will blink at a rate of 5 flashes per second to show that the detector needs attention.

HART Troubleshooting

1. Verify that the IR400 is configured for HART
2. Verify that the HART modem or HART handheld device (375 or 475) is working by checking it against another HART field device
3. Verify that the HART software or handheld device has the DD for the IR400. If the DD is not present, download it from the HART Communication Foundation (HCF) website.
4. Verify the IR400 wiring
5. Verify that power is off when removing or attaching wires
 - Red to power
 - Black to common
 - White to a 250 ohm resistor, and the other end of resistor to common. Resistor tolerance should be +/-5% or less.
 - Verify HART modem or 475 wiring: Leads are across the 250 ohm resistor
 - After verifying the IR400 wiring, verify that power is on to the IR400 and to the HART modem or handheld device
6. Verify IR400 4-20mA output. When no gas and no faults are present, a voltmeter across the 250 ohm resistor will read 1.0 volt DC.



Table showing the fault conditions and corrective action required:

FAULT CODE	MODBUS FAULT FLAG REGISTER 2	ANALOG OUTPUT (mA)		DESCRIPTION	POSSIBLE CAUSE	CORRECTIVE ACTION
		HART	non-HART			
F0	Bits 3 & 14	2mA for 30s then 1.25mA	2mA for 30s then 0mA	Gas Concentration is Excessively Negative	1) Fouling of the detector windows or beam path is excessive and requires attention	1) Clean detector beam path and windows.
F1	Bits 0 & 1	2	2	Gas Concentration is Negative	1) Detector windows or beam path are beginning to be obscured.	1) Clean detector beam path and windows.
F2	Bit 6	1.25	0	Failed to Complete Calibration	1) Cal bottle empty and time-out occurred 2) Failed to remove gas at end of CAL and time-out occurred. 3) Leaky CAL cup resulting in unstable signal. 4) Attempted to CAL with too much wind resulting in unstable signal.	1) Obtained filled CAL bottle and re-CAL. 2) Remove gas when directed. 3a) Check CAL cup for proper seating on unit. 3b) Check CAL cup seal and replace CAL cup if damaged. 4) Calibrate at a much less windy time or shield the unit and CAL cup from the wind.
F3	Bit 2	2mA for 30s then 1.25mA	2mA for 30s then 0mA	Beam Block	1) Detector windows or beam path are blocked by dirt, spider webbing or other foreign matter. 2) Detector or source failure.	1) Clean detector beam path and windows. 2) The IR400 must be returned to the factory or authorized service center for repair.
F4		1.25	0	Communications Fault (Applies to IR400M display only)	1) Incorrect communications set-up. 2) Communications wiring open. 3) Communications wiring shorted.	1) Ensure baud rate, data format and address matches at both the IR400 and the bus master. 2) Check and correct wiring. 3) Check and correct wiring.
F5	Bit 4	1.25	0	CAL Wire (brown) Shorted	1) CAL Wire (brown) not in connector	1) Check and ensure proper connection of wire to board connector
F6	Bit 5	1.25	0	Low Supply Voltage	1) Power supply not outputting greater than 20VDC. 2) Voltage loss due to wiring.	1) Check the supply voltage and replace power supply if necessary 2) Check the supply voltage at the IR400 field and adjust supply to +24VDC at the IR400 or replace wiring with larger gauge.
F7	Bits 9 - 13 & 15	1.25	0	Electronics Error	1) Internal memory glitch 2) Internal error with the electronics.	1) Cycle power, wait 2 minutes, if the fault clears then check all menu settings and recalibrate the IR400. 2) Call your local General Monitors representative for advice.
F8	Bit 7	1.25	0	Failed to Zero	1) Unstable signal due to gas present.	1) Ensure clean air is available for zeroing or provide zero air to the IR400 during zeroing.
F9	Bit 8	1.25	0	CAL Check Period Exceeded	1) Test gas still present after gas check completed.	1) Remove the gas

7.0 Modbus Interface

The IR400 has a single Modbus compatible interface for connection to control room equipment such as programmable logic controllers (PLCs). The Modbus interface is also used to connect IR400 detectors to the IR4000M multi-point monitor.

A separate manual for the IR400 Modbus registers and a programming guide is available from the General Monitors' website.

8.0 Customer Support

Area	Phone/Fax/Email
UNITED STATES	
	Toll Free: +1-800-446-4872
Corporate Office: 26776 Simpatica Circle Lake Forest, CA 92630	Phone: +1-949-581-4464 Fax: +1-949-581-1151 Email: info@generalmonitors.com
	Phone: +1-281-855-6000
9776 Whithorn Drive Houston, TX 77095	Fax: +1-281-855-3290 Email: gmhou@generalmonitors.com
UNITED KINGDOM	
Heather Close Lyme Green Business Park Macclesfield, Cheshire, United Kingdom, SK11 0LR	Phone: +44-1625-619-583 Fax: +44-1625-619-098 Email: info@generalmonitors.co.uk
IRELAND	
Ballybrit Business Park Galway Republic of Ireland	Phone: +353-91-751175 Fax: +353-91-751317 Email: info@gmil.ie
SINGAPORE	
No. 2 Kallang Pudding Rd. #09-16 Mactech Building Singapore 349307	Phone: +65-6-748-3488 Fax: +65-6-748-1911 Email: genmon@gmpacifica.com.sg
MIDDLE EAST	
LOB12, #G20 P.O. Box 61209 Jebel Ali, Dubai United Arab Emirates	Phone: +971-4-8143814 Fax: +971-4-8857587 Email: gmme@generalmonitors.ae

Table 5: GM Locations

9.0 Appendix

9.1 Warranty

General Monitors warrants the Model IR400 to be free from defects in workmanship or material under normal use and service within two (2) years from the date of shipment.

General Monitors will repair or replace without charge any such defective equipment found to be defective during the warranty period. Full determination of the nature of, and responsibility for, defective equipment will be made by General Monitors' personnel.

Defective or damaged equipment must be shipped prepaid to General Monitors' plant or representative from which shipment was made. In all cases this warranty is limited to the cost of the equipment supplied by General Monitors. The customer will assume all liability for the misuse of this equipment by its employees or other personnel.

NOTE: The Model IR400 Infrared Point Detector is easy to install; however, you should read and understand this manual before attempting to install or operate the device. It includes important safety information.

All warranties are contingent upon proper use in the application for which the product was intended and do not cover products which have been modified or repaired without General Monitors' approval, or which have been subjected to neglect, accident, improper installation or application, or on which the original identification marks have been removed or altered.

Except for the express warranty stated above, General Monitors disclaims all warranties with regard to the products sold, including all implied warranties of merchantability and fitness and the express warranty stated herein are in lieu of all obligations or liabilities on the part of General Monitors for damages including, but not limited to, consequential damages arising out of/or in connection with the use or performance of the product.

9.2 Principle of Operation

Most gases absorb infrared radiation in specific wavelengths or bands that are characteristic of the chemical structure of molecules in the gas. All hydrocarbon gases absorb infrared radiation, but to differing degrees. Gases, to be infrared active, must have an electric dipole moment. The Model IR400 is based on measuring absorption of infrared radiation passing through a volume of gas.

Absorption of the radiation follows the Beer - Lambert Law, which states “the transmittance T of radiation through an absorbing medium decreases exponentially by the product of the extinction coefficient A, the concentration C and the path length L”:

$$T = \exp(-ACL)$$

The Model IR400 uses a dual source, single detector measurement method. One source operates at a wavelength where absorption of a specific gas (or gases) occurs (the active wavelength). The reference source operates at a wavelength that is adjacent to the active wavelength but not absorbed by the gas (or gases). By comparing the signals from these two sources the concentration of the gas can be measured using the differential absorption technique.

This method of gas detection comes under what is commonly known as the non-dispersive infrared (NDIR) absorption principle. The reference wavelength is chosen suitable to compensate for any interference that can otherwise occur from atmospheric variation (e.g. humidity, dust, snow, fog, steam, temperature, etc.).

Control Electronics

The Model IR400 operates from an unregulated +24 VDC (nominal) input, which is fed to an onboard power-supply that produces all of the necessary voltages within the unit. The microprocessor constantly monitors the infrared wavelengths and performs mathematical operations on these values in conjunction with values obtained during the factory set-up process.

The microprocessor generates output information and feeds it to the digital analog converter to produce a 4 to 20 milliampere (mA) signal that is proportional to the 0 to 100% LEL (or methane % by volume) concentration of gas at the sensor. The microprocessor program also monitors other conditions such as the supply voltage and the optical path integrity.

The Model IR400 provides a two-wire RS-485 addressable communications link conforming to the Modbus protocol that is used to monitor the IR400's status and settings in order to simplify installation and maintenance.



9.3 Specifications

9.3.1 System Specifications

Detector Type:	Infrared absorption
Detector Life:	Greater than 5 years
Measuring Range:	0 to 100% LEL
Zero Drift:	< 2% per year
Response Time: <i>(With 100% LEL methane applied)</i> <i>(With 100% LEL ethylene applied)</i>	T50 ≤ 1.5 seconds, T60 ≤ 1.5 seconds T90 ≤ 3 seconds T50 ≤ 1.5 seconds, T60 ≤ 2 seconds T90 ≤ 4 seconds All times are with the splash guard with screen
Accuracy @ 25° C:	±3% FS ≤ 50% FS, ±5% FS > 50% FS
Gas Calibrations	Methane, Propane, Ethane, Ethylene, Butane, Hexane, Pentane at LEL levels defined by ISO 10156/NFPA 325 and at levels defined by IEC 60079-20. <i>Consult factory for other calibrations.</i>
Readout/Relay Display Modules:	DC110: Multi-Channel, Rack Mounted ¹ TA102A: Single Channel, Zero Two Series ² IR4000 display and relay alarms
Malfunctions Monitored:	Re-calibration Error Optics Failure/Blockage Low Supply Voltage Reference or Active Lamp Failure Heater Failure Time to Re-zero unit Program Memory Checksum Error (EPROM) Data Non-Volatile Memory Checksum Error (EEPROM) Short Circuit on CAL_IO Wire
Warranty:	Two years
Approvals:	CSA,,FM, ATEX, IECEX, BV, CE Marking, SIL 3 suitable. Performance Certified to CSA 22.2 No 152, FM 6310/6320, EN 60079-29-1.

FM required statement: "This Approval does not include or imply Approval of apparatus to which the subject instrumentation may be connected. In order to maintain an FM Approved system, the apparatus to which this instrument is connected, must also be Approved by FM Approvals."

¹ DC110 is not approved for use in ATEX installations

² Rev E S/W and up for EU installations

9.3.2 Mechanical Specifications

Length:	8.87 inches (225 mm)
Diameter:	2.9 in (74 mm)
Weight:	3 lbs (1.35 kg) for aluminum 6 lbs (2.7 kg) for stainless steel
Mounting:	3/4" NPT threads
Enclosure:	Marine Aluminum or Stainless Steel; Explosion proof, IP66, Type 4X

9.3.3 Electrical Specifications

Input Power:	
absolute min	20 V
nominal	24 V
absolute max	36 V
max. wattage	4.8 W @ +24 VDC
max. current	200 mA @ +24 VDC
ripple maximum allowed	1 V pk-pk

NOTE: Customer supplied PSU must meet requirements IEC 1010-1 limiting current to 8A under Fault conditions, in order to comply with CE Marking requirements.

Analog Signal:	
Range	0 - 21.7 mA
Load (max. resistance)	600 Ω
Current Level (mA)	
0	Startup mode and critical fault for non HART unit
1.25*	Startup mode and critical fault for HART unit
1.5*	Zero, Calibration and Gas Check Mode
2*	Dirty Optics
4 – 20	0 – 100% LEL
20.1 – 21.7	Over range

* HART units can be configured to never output current less than 3.5 mA if the host equipment is incapable of working below this level.

Area Classification:

IR400

Class I, Divisions 1 & 2, Groups B, C and D (Ta = -40°C to +75°C), (Ta = -40°C to +60°C for ethylene only), IP66, Type 4X

Ex d, IIB+H₂ T5 Gb, IP66 (Ta = -60°C to +75°C)

Ex tb IIIC T100°C Db

IR400 Junction Box / Zero Switch Assembly

Ex d e mb IIB+H₂ T5 Gb

Ex mb tb IIIC T100°C Db

(Ta = -40°C to +70°C)

IP66 and IP67

RFI/EMI Protection:	Complies with EN50270, EN61000-6-4
----------------------------	------------------------------------

9.3.4 Analog Current Output

The following table shows the values of the analog output when in certain modes or fault conditions.

Condition Type	Non-HART Units	HART Units	HART Override Mode*
Start Up, Fault	0 mA	1.25 mA	3.5 mA
Zero, Gas Check or Cal	1.5 mA	1.5 mA	3.5 mA
Dirty Optics	2.0 mA	2.0 mA	3.5 mA
0-100% LEL	4 – 20 mA	4 – 20 mA	4 – 20 mA
Over-range	21.7 mA	21.7 mA	21.7 mA

Table 6: Analog Current Output

* HART units can be configured to never output current less than 3.5 mA if the host equipment is incapable of working below this level.

9.3.5 Recommended Cable Lengths

Power – The maximum distance between the IR400 and the power source varies according to the wire size. Maximum cable resistance = $V \text{ drop} / I \text{ device} = 4.0 \text{ V} / 0.20 \text{ A} = 20\Omega$, where $V \text{ drop} = V \text{ supply} - V \text{ device}$ and $V \text{ supply} = +24 \text{ VDC}$. Example distances are below.

AWG	Stranded Cable ($\Omega/1000 \text{ ft}$)	Feet	Meters
12	1.71	5840	1780
14	2.73	3660	1120
16	4.35	2290	700
18	6.92	1440	440
20	10.9	910	280

Table 7: Maximum Distance between IR400 and Power Source

Analog Output Signal – The maximum distance = $\text{Cable loop resistance} / (2 \times \text{cable resistance} / 1000 \text{ feet})$. Example distances are given below for an analog input device with 250 ohms input resistance and a cable loop resistance of 50 ohms..

AWG	Stranded Cable ($\Omega/1000 \text{ ft}$)	Feet	Meters
14	2.73	9150	2780
16	4.35	5740	1740
18	6.92	3610	1100
20	10.9	2290	690

Table 8: Maximum Distance between IR400 and Analog Input Device

9.4 Environmental Specifications

Temperature Range:

Operating	-40°F to +167°F (-40°C to +75°C)
<i>(Ethylene only)</i>	-40°F to +140°F (-40°C to +60°C)
Storage	-76°F to +185°F (-60°C to +85°C)

Humidity Range:

10 to 95% RH non-condensing
Accuracy is not affected by humidity as long as no condensation accumulates on the windows

9.5 Communications

9.5.1 RS-485 Interface

The Model IR400 has built-in serial communications in the form of a half duplex RS-485 digital serial interface designed to conform to EIA-485 specifications. The default settings are 9600 baud with 1 start bit, 8 data bits, 1 stop bit and no parity. The interface supports Modbus RTU communications.

9.5.2 Modbus RTU

A programming manual is available from the General Monitors website that gives details on all the available Modbus RTU commands.

9.5.3 HART

The IR400 HART Field Device Specification provides details on HART commands. The specification is available from the General Monitors website.

9.6 Engineering Documentation

IR400 wires are 12" \pm 0.13" long.

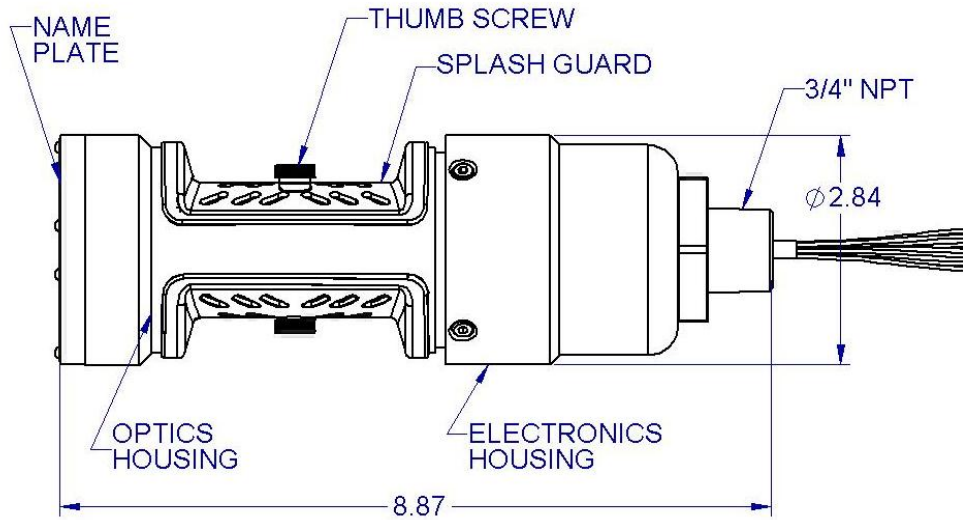

Figure 10: Outline and Dimensional Drawing, IR400, Inch Measurements

9.7 Ordering Information

9.7.1 System Components

Description	Part Number
Model IR400 Infrared Point Detector Standard (Methane)	IR400
Instruction Manual - Model IR400	MANIR400
DC110 Eight Channel Readout/Relay Display Module, Rack Mounted	DC110
TA102A Single Channel Zero Two Series Trip Amplifier	TA102A
IR4000 multi-point monitor for up to 8 IR400s connected via Modbus	IR4000M
IR4000 single-point monitor connected using analog output and CAL signal	IR4000S

9.7.2 Spare Parts and Accessories

To order spare parts and/or accessories, please contact the nearest General Monitors representative, or General Monitors directly, and give the following information:

1. Part Number
2. Description
3. Quantity

9.7.3 Recommended Spare Parts for One (1) Year

31037-1

Double-Magnet Assembly if a zero switch is used



9.7.4 Accessories

31305-1	Junction Box with magnetic switch, CSA/FM
31421-3	Junction Box with magnetic switch, ATEX
31305-2	Junction Box without magnetic switch, CSA/FM
31421-4	Junction Box without magnetic switch, ATEX
32554-1	Calibration Cup / Flow Block
32545-1	Splash Guard standard
32545-2	Splash Guard for use with remote cal
32545-3	Splash Guard with no screen for areas with occasional moisture
32545-4	Splash Guard with no screen for remote cal
31306-1	Duct Mount Junction Box
32548-Specify Gas	Gas bottle with regulator and calibration cup
31420-1	Flow Block for gas sampling system
31545-1	Rain Guard Assembly



ADDENDUM
Product Disposal Considerations

This product may contain hazardous and/or toxic substances.

EU Member states shall dispose according to WEEE regulations. For further General Monitors' product WEEE disposal information please visit: www.generalmonitors.com/faqs

All other countries or states: please dispose of in accordance with existing federal, state and local environmental control regulations.