

Features

- 2-channel isolated barrier
- 24 V DC supply (bus powered)
- Dry contact or NAMUR inputs
- 2 relay contact outputs
- Line fault detection (LFD)
- Up to SIL 2 acc. to IEC 61508

Function

This isolated barrier is used for intrinsic safety applications. It transfers digital signals (NAMUR sensors/mechanical contacts) from a hazardous area to a safe area.

The proximity sensor or switch controls a form A normally open relay output for the safe area load. The module output changes state when the input signal changes state. The mode of operation can be reversed with the switches S1 and S3 on the side of the unit.

Line fault detection (LFD) can be selected or disabled via the switches S2 and S4.

During an error condition, the relay reverts to its de-energized state and the LEDs indicate the fault. A separate fault output bus is available. The fault conditions can be monitored via a Fault Indication Board.

This module mounts on a HiC Termination Board.

Assembly

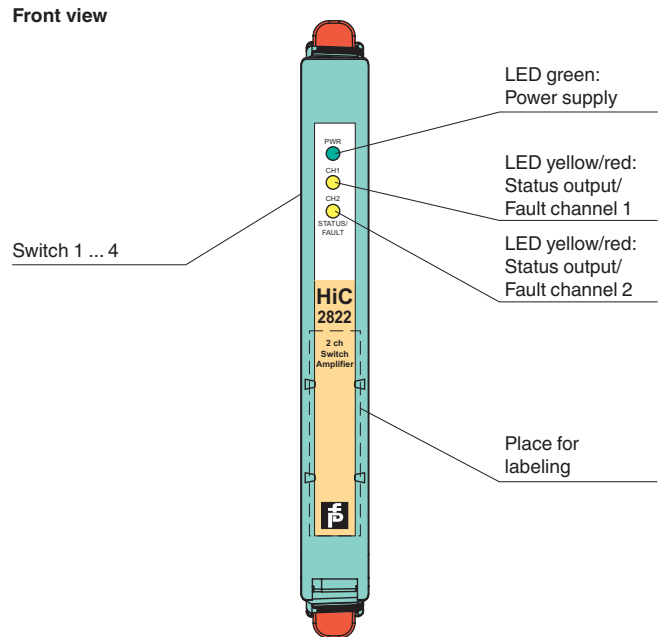

SIL 2

Connection

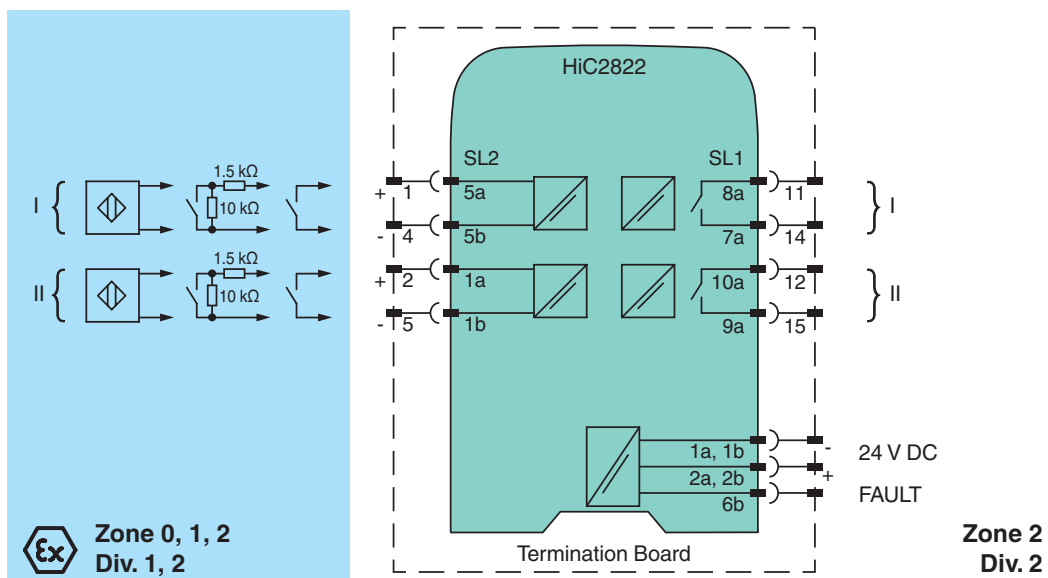

Release date 2018-05-08 08:12 Date of issue 2018-05-08 216690_eng.xml



Refer to "General Notes Relating to Pepperl+Fuchs Product Information".

Pepperl+Fuchs Group
www.pepperl-fuchs.com

USA: +1 330 486 0002
pa-info@us.pepperl-fuchs.com

Germany: +49 621 776 2222
pa-info@de.pepperl-fuchs.com

Singapore: +65 6779 9091
pa-info@sg.pepperl-fuchs.com

General specifications		
Signal type		Digital Input
Functional safety related parameters		
Safety Integrity Level (SIL)		SIL 2
Supply		
Connection		SL1: 1a(-), 1b(-); 2a(+), 2b(+)
Rated voltage	U_r	19 ... 30 V DC bus powered via Termination Board
Ripple		$\leq 10 \%$
Rated current	I_r	$\leq 30 \text{ mA}$
Power dissipation		$\leq 600 \text{ mW}$
Power consumption		$\leq 600 \text{ mW}$
Input		
Connection side		field side
Connection		SL2: 5a(+), 5b(-); 1a(+), 1b(-)
Rated values		acc. to EN 60947-5-6 (NAMUR), see system description for electrical data
Open circuit voltage/short-circuit current		approx. 10 V DC / approx. 8 mA
Switching point/switching hysteresis		1.2 ... 2.1 mA / approx. 0.2 mA
Line fault detection		breakage $I \leq 0.1 \text{ mA}$, short-circuit $I \geq 6.5 \text{ mA}$
Pulse/Pause ratio		$\geq 20 \text{ ms} / \geq 20 \text{ ms}$
Output		
Connection side		control side
Connection		SL1: 8a, 7a; 10a, 9a
Output I		signal ; relay
Output II		signal ; relay
Contact loading		50 V DC / 0.5 A
Minimum switch current		2 mA / 24 V DC
Energized/De-energized delay		$\leq 20 \text{ ms} / \leq 20 \text{ ms}$
Mechanical life		10^7 switching cycles
Fault indication output		
Connection		SL1: 6b
Output type		open collector transistor (internal fault bus)
Transfer characteristics		
Switching frequency		$\leq 10 \text{ Hz}$
Galvanic isolation		
Output/power supply		basic insulation acc. to EN 50178, rated insulation voltage of 50 V AC
Output/Output		basic insulation acc. to EN 50178, rated insulation voltage of 50 V AC
Indicators/settings		
Display elements		LEDs
Control elements		DIP-switch
Configuration		via DIP switches
Labeling		space for labeling at the front
Directive conformity		
Electromagnetic compatibility		
Directive 2014/30/EU		EN 61326-1:2013 (industrial locations)
Conformity		
Galvanic isolation		EN 50178:1997
Electromagnetic compatibility		NE 21:2006 For further information see system description.
Degree of protection		IEC 60529:2001
Input		EN 60947-5-6:2000
Ambient conditions		
Ambient temperature		-20 ... 60 °C (-4 ... 140 °F)
Mechanical specifications		
Degree of protection		IP20
Mass		approx. 100 g
Dimensions		12.5 x 128 x 106 mm (0.5 x 5.1 x 4.2 inch)
Mounting		on Termination Board
Coding		pin 1 and 2 trimmed For further information see system description.
Data for application in connection with hazardous areas		
EU-Type Examination Certificate		BASEEFA 06 ATEX 0093 X
Marking		 II (1)G [Ex ia Ga] IIC  II (1)D [Ex ia Da] IIIC  I (M1) [Ex ia Ma] I

Release date 2018-05-08 08:12 Date of issue 2018-05-08 216690_eng.xml

Refer to "General Notes Relating to Pepperl+Fuchs Product Information".

Pepperl+Fuchs Group
www.pepperl-fuchs.com

USA: +1 330 486 0002
pa-info@us.pepperl-fuchs.com

Germany: +49 621 776 2222
pa-info@de.pepperl-fuchs.com

Singapore: +65 6779 9091
pa-info@sg.pepperl-fuchs.com

Input		[Ex ia Ga] IIC, [Ex ia Da] IIIC, [Ex ia Ma] I
Voltage	U_o	10.5 V
Current	I_o	17.1 mA
Power	P_o	45 mW (linear characteristic)
Supply		
Maximum safe voltage	U_m	253 V AC (Attention! U_m is no rated voltage.)
Permissible connection values [Ex ia]		
Output		
Contact loading		50 V DC / 0.5 A
Maximum safe voltage	U_m	253 V AC (Attention! The rated voltage can be lower.)
Certificate		PF 08 CERT 1047 X
Marking		⊕ II 3G Ex nA nC IIC T4 Gc
Galvanic isolation		
Input/Output		safe electrical isolation acc. to IEC/EN 60079-11, voltage peak value 375 V
Input/power supply		safe electrical isolation acc. to IEC/EN 60079-11, voltage peak value 375 V
Directive conformity		
Directive 2014/34/EU		EN 60079-0:2012+A11:2013 , EN 60079-11:2012 , EN 60079-15:2010
International approvals		
FM approval		
Control drawing		16-534FM-12 (cFMus)
UL approval		
Control drawing		116-0434
IECEX approval		IECEX BAS 06.0026X
Approved for		[Ex ia Ga] IIC, [Ex ia Da] IIIC, [Ex ia Ma] I
General information		
Supplementary information		Observe the certificates, declarations of conformity, instruction manuals, and manuals where applicable. For information see www.pepperl-fuchs.com .

Configuration

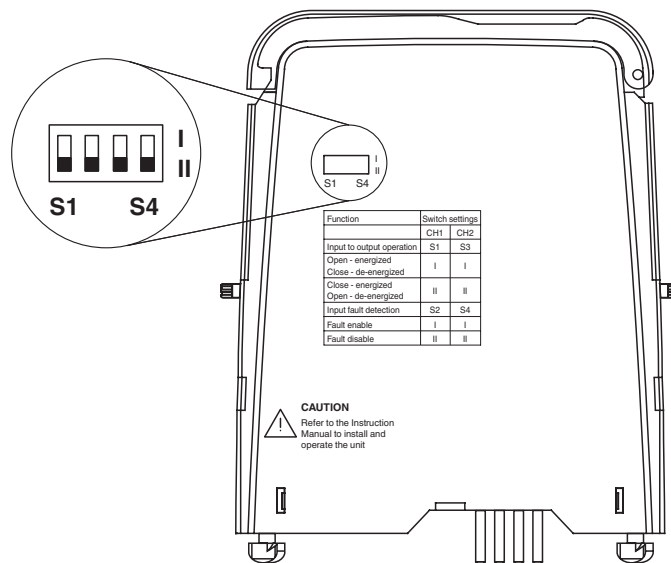

Configure the device in the following way:

- Push the red Quick Lok Bars on each side of the device in the upper position.
- Remove the device from Termination Board.
- Set the DIP switches according to the figure.



The pins for this device are trimmed to polarize it according to its safety parameter. Do not change! For further information see system description.

Release date 2018-05-08 08:12 Date of issue 2018-05-08 216690_eng.xml

Maximum switching power of output contacts

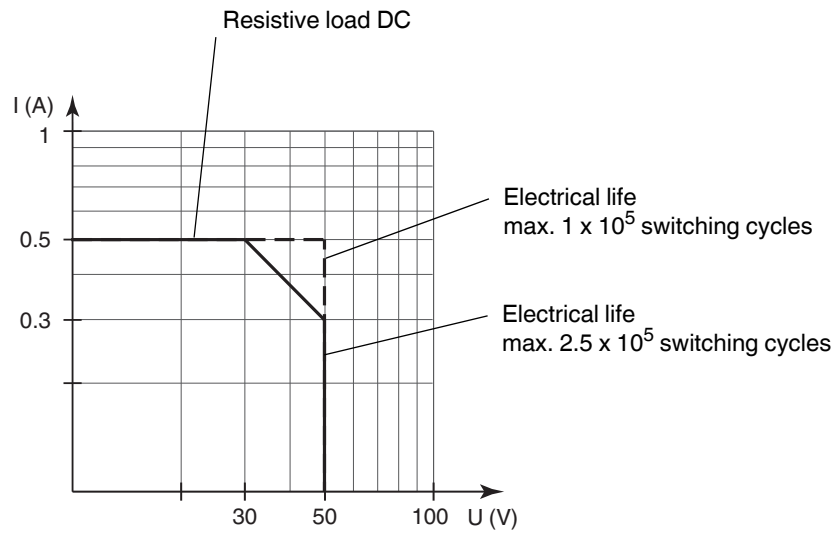

The maximum number of switching cycles is depending on the electrical load and may be higher when reduced currents and voltages are applied.