



**HR-1211
HR-1213
HR-1226**

- relays for conductive limit value detection
- compact design
- the relays are designed for different response ranges
- measuring circuit according to VDE 0100 part 410 "Low switching voltages" (< 50 V AC / < 100 V DC)
- min. - max. - control possible
- open / closed circuit principle can be selected

Function:

The relay provides the ac measuring voltage for the conductive sensor and detects the low alternating current which flows in the electrode after contact with the medium.

The switching amplifiers are voltage and temperature stabilised and guarantee reproducible switching characteristics.

An electronic holding contact allows min.-max. control.

Since the conductivity of the media can be quite different, the relays can be ordered with graduated response sensitivities or are switchable using bridges.

The "closed circuit principle" allows the relay to be used for tasks with high safety requirements.

Open / closed circuit principle:

HR-1213:
specify when ordering

HR-1226:
bridge 4-6 = closed circuit principle

In the closed circuit principle, the relay energises when voltage is applied. It de-energises when the limit condition is reached.

Order No.:

HR-12112 .

HR-1213 . .

HR-122620

Operating mode:

- without de-energising delay
- K1 and K2 open circuit 2
- K1 and K2 closed circuit 3
- K1 closed, K2 open cir. ... 4

with de-energising delay (approx. 1 sec.)

- K1 and K2 open circuit ... 5
- K1 and K2 closed circuit 6
- K1 closed, K2 open cir. ... 7

4 measuring ranges selected using slide switches S1 - S4

- 0 - 1 kΩ
- 1 kΩ - 10 kΩ
- 10 kΩ - 100 kΩ
- 100 kΩ - 500 kΩ

compensation within the desired range via a potentiometer on the front panel

Response sensitivity:

- 25 kΩ permanently set .. 1
- 150 kΩ permanently set .. 2
- 1000 kΩ permanently set . 3
- 2-30 kΩ adjustable 5
- 5-150 kΩ adjustable 6
- 50-1000 kΩ adjustable 7

Response sensitivity:

- 1
- 2
- 3
- 5
- 6
- 7

Display and operating elements:

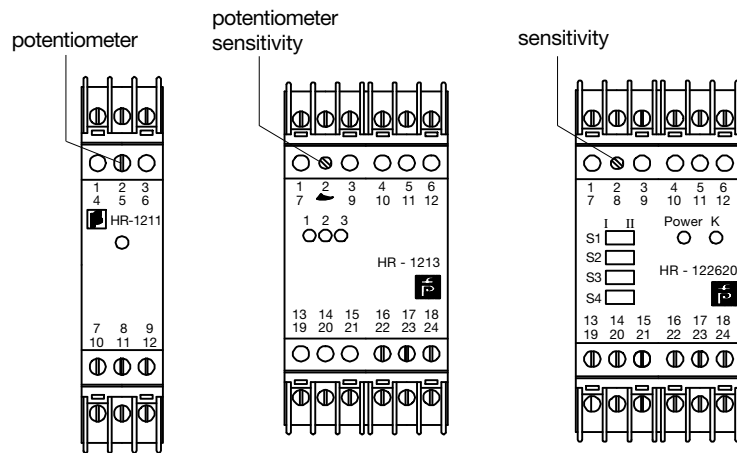

LED (yellow): changeover

LED 1: supply
LED 2: changeover 1
LED 3: changeover 2

LED (green): power
LED (yellow): K c/o

sensitivity - selector switches

meas.range/switches	S ₁	S ₂	S ₃	S ₄
0 - 1K	I	I	II	II
1 K - 10 K	I	I	I	II
10 K - 100 K	II	I	I	I
100 K - 500 K	II	II	I	I



	HR-1211	HR-1213	HR-1226
Terminal assignment	electrodes: 1: gnd 2: MIN 3: MAX changeover: 7-8: break switch 7-9: make switch power: 11: L1 12: N	electrodes: 1: gnd 2: MIN 3: MAX changeover 1: 19-21: break switch 19-20: make switch changeover 2: 13-15: break switch 13-14: make switch power: 23: L1 24: N	electrodes: 1: gnd 2: MIN 3: MAX changeover: 16-17: break switch 16-18: make switch power: 23: L- (N) 24: L+ (L1) bridge 4-6: quiescent current
Technical Data	HR-1211	HR-1213	HR-1226
Response sensitivity	25 kΩ permanently set 1 150 kΩ permanently set 2 1000 kΩ permanently set 3 2 - 30 kΩ adjustable 5 5 - 150 kΩ adjustable 6 50 -1000 kΩ adjustable 7	25 kΩ permanently set 1 150 kΩ permanently set 2 1000 kΩ permanently set 3 2 - 30 kΩ adjustable 5 5 - 150 kΩ adjustable 6 50 -1000 kΩ adjustable 7	0 - 1 kΩ 1 kΩ - 10 kΩ 10 kΩ - 100 kΩ 100 kΩ - 500 kΩ
Supply	AC 230 V ±10% (48 ... 62 Hz) other values on request approx. 3 VA		DC 24 V (±20%) other values on request approx. 3 VA
Nominal voltage			
Power consumption			
Input / measuring circuit			
Voltage	AC 12 V (50Hz)	AC 13 V	AC 5 V (20 Hz)
max.current	4.5 mA	2.5 mA	0.5 mA
Output / open circuit			
Voltage	1 isolated changeover contact DC 120 V / AC 250 V	2 isolated changeover contacts DC 120 V / AC 250 V	1 isolated changeover contact DC 120 V / AC 250 V
Current	2 A / 2 A (cos φ 0.7)	2 A / 2 A (cos φ 0.7)	2 A / 2 A (cos φ 0.7)
max. power	120 W	120 W	120 W
Environmental conditions	253 K ... 333 K (-25 °C ... +65 °C)		
Ambient temperatures			
Mechanical	compact design W / H / D 20 or 40 / 92.5 / 110 mm, Makrolon screw connections, max. 2 x 2.5 mm ² snap on mounting onto standard mounting rail DIN EN 50 022 (35 mm) or screwed down with a removeable strap IP 20		
Housing			
Connection			
Fixing			
Type of protection			
Accessories	protective housing IP 55 HR-9505 (on request)		

Issue date 20.07.95